

# Arcade Creek

Recreation and Park District

BOARD OF DIRECTORS MEETING  
THURSDAY MAY 18, 2023 @ 6:00 p.m.  
At the Herzog Community Center Oak (Small) Room  
4855 Hamilton Street, Sacramento, CA 95841

## AGENDA

1. **Call to Order and perform Roll Call.** (Chair – Alex Vassar)
2. **Public Comment** – this is the opportunity for members of the public to address the Board on any topic within the Board’s jurisdiction NOT listed on the agenda. The Board will take comments only but cannot act upon any item not listed on the Agenda.  
**Each speaker will be limited to five minutes of time.**  
The Board will not receive comments relating to District Personnel during this time. These comments must be made in writing to the General Manager and in the case of the General Manager made in writing to the Chairperson of the Board.  
**Questions about the daily operation of the park district should be directed to the General Manager during normal working hours when possible.**  
Comments related to a specific item on the agenda will be received by the Board at that time during the meeting. Members of the public may gain recognition by registering with the Secretary to the Board prior to the start of the meeting or by raising their hand to be recognized by the Chairperson of the Board at the time they wish to speak, and public comment is welcomed.  
**Although public comments on agenda items are welcomed during each discussion, public comments of a general nature will not be received once the Board Chair has closed the Public Comment period.**
3. **Announcements** (Staff)
4. **Task Started, Revised or Accomplished**
5. **Consent Agenda**—*these items are expected to be routine and noncontroversial. Any Board member may ask that an item be removed from the Consent Items list and it will be considered as a separate item under New Business. The Board by motion and second will be asked to approve all items on the list without discussion.*
  - a. **Draft Meeting Minutes:** Board Meeting 4/20/2023
  - b. **FY 22-23 Period 10 Financial Reports 339A**
  - c. **FY 22-23 Period 10 Financial Reports 339D**
  - d. **FY 22-23 Period 10 Multi Accounts Revenue Reports**
  - e. **FY 22-23 Period 10 Payroll Report**
  - f. **FY 22-23 Period 10 Rental & Misc. Revenue Report Attributed To Stated Period**
  - g. **Correspondence received and sent**
  - h. **General Managers Report**
6. **Old Business:**
  - a. Discussion regarding the buildings at Oakdale Elementary (Gym and Community Center Room)
  - b. Prioritize projects for FY 2023-24

Mailing Address: PO Box 418114, Sacramento, CA 95841-8114  
Physical Address: 4855 Hamilton Street, Sacramento, California 95841-3414  
(916) 482-8377 Email: [acrpd@acrpd.com](mailto:acrpd@acrpd.com)

**6. Old Business: (cont.)**

- c. SMUD Complete Energy Solutions Proposal

**7. New Business:**

- a. Finance-Budget Committee proposal for FY 2023-24, 339A General Budget and 339D District Projects Preliminary Budgets.

**Public Hearing:**

FY 2023-24 Proposed Budget presentation and to receive public comments on the documents.

- b. Update from committee regarding Staples Construction meeting.

**8. Board Discussion:**

- a. General discussion on topics for future meetings

**9. Adjournment of the meeting.**

The next regular Board of Directors meeting will be held Thursday June 15, 2023, at 6:00 p.m.

**NOTICE**

Where proper or considered necessary, the Board may act on any item listed on the Agenda; including items listed as information items. Public documents relating to any open session item(s) listed on this agenda that are distributed to the members of the Board of Directors less than 72 hours before the meeting is available for public inspection in the District's Office at 4855 Hamilton Street, Sacramento, CA 95841.

In compliance with the Americans with Disabilities Act, if you have a disability, and you need a related modification or accommodation to take part in this meeting, please contact the Arcade Creek Recreation and Park District office at (916) 482-8377. Requests must be made as early as possible, and at least three full business days (72-hours) before the start of the meeting.

The Agenda is posted on the District's website ([www.acrpd.com](http://www.acrpd.com)), are electronically mailed to residents whom have requested an electronic version and are posted for public inspection on the bulletin board just outside the District Office's front door. A full hard copy is available at the front desk a minimum of 72 hours in advance.

**Mailing Address: PO Box 418114, Sacramento, CA 95841-8114**  
Physical Address: 4855 Hamilton Street, Sacramento, California 95841-3414  
(916) 482-8377 Email: [acrpd@acrpd.com](mailto:acrpd@acrpd.com)

## 8. Tasks Started or Accomplished

5/18/2023 Meeting

File: District Planning Goals/Task Started or Accomplished

### Priority Legend

- 1 To Do ASAP
- 2 Request John w/Resotration Landscape
- 3 22/23 - Budget Year To Do
- 4 Future Budget Years

### Safety

### Appearances

### Amenities

Priority	Description	Status	Priority	Description	Status	Priority	Description	Status
1	Tow sign / tow trucks	COMPLETED	1	Interior lights HSP rental facilities	DIRECTED	2	Remove baseball diamond backstop frame	COMPLETED
2	Park benches/ tables	COMPLETED	1	ACP - Basketball rims	STARTED	3	Basketball courts @ HSP & ACP	STARTED
3	HSP lights - Park restrooms, facilities, office	STARTED	2	HSP Group picnic area	COMPLETE	3	HSP Playground equipment (update/add)	
3	ACP lights - Park restrooms		3	Signs on Jo Smith Nature Trail (Interpretive)	STARTED	3	Pickle Ball Courts	STARTED
4	Creek Erosion		3	Maintenance shop		3	Volleyball courts	
2	Skunk trapping at office 7 skunks caught	COMPLETED	3					
2	Office emergency exit doors	too expensive	2	Tagging @ HSP 11/5/2022	COMPLETED			
			2	HSP poles & chains removed & holes filled in	COMPLETED			
			1	Additional trees fell down during rain/wind	COMPLETED			

**MINUTES**  
Of  
The Arcade Creek Recreation & Park District  
Meeting of the Board of Directors

Held on

**Thursday April 20, 2023 at 6:00 p.m.**

**Meeting conducted in the Herzog Community Center Oak (Small) Room**

---

**Call to Order and Perform Roll Call:** Chairperson A. Vassar called the meeting to order at 6:00 pm

**Board Members Present:** A. Vassar, M. Hanson, S. Miller

**Board Members Absent:** A. Gualderama, T. Dworetzky arrived at 6:02 pm

**Staff Members Present:** Lisa Gonzalez, Kim Cook, Anita Petersen

**Legal Counsel Present:** No

**Auditor Present:** No

**Presentation(s):** None

**Visitor(s) That Signed In:** Virg Anderson

---

**2. PUBLIC COMMENTS:** None

Director T. Dworetzky arrived.

**3. ANNOUNCEMENTS:** The GM informed the board that she would be absent from the May 18, 2023 board meeting, as she would be attending the CARPD Conference.

**4. TASK STARTED, REVISED OR ACCOMPLISHED:** List reviewed.

**5. CONSENT ITEMS:**

- a. **Draft Meeting Minutes:** Board Meeting 3/16/2023
- b. FY 22-23 Period 9 **Financial Reports 339A**
- c. FY 22-23 Period 9 **Financial Reports 339D**
- d. FY 22-23 Period 9 **Multi Accounts Revenue Reports**
- e. FY 22-23 Period 9 **Payroll Report**
- f. FY 22-23 Period 9 **Rental & Misc. Revenue Report Attributed To Stated Period**
- g. Correspondence **received and sent**
- h. General Managers Report

**Motion No. 1:** It was moved by Director M. Hanson and seconded by Director T. Dworetzky to approve consent items as presented after clarification on a few items in the GM report.

## MINUTES of Board of Directors Meeting

April 20, 2023

Page 2 of 3

### 5. CONSENT ITEMS: (cont.)

**Motion Carried:** 4 Ayes, 0 Noes, 1 Absent, 0 Abstained

Ayes: A. Vassar, M. Hanson, S. Miller, T. Dworetzky

Absent: A. Gualderama

Abstained:

Vacant:

Chairperson A. Vassar appointed a committee, that includes Director M. Hanson and the GM Lisa Gonzalez to set up a meeting with Staples Construction to determine for what reason(s) there seems to be a delay in completing the contracted project for the ACP public restroom.

### 6. OLD BUSINESS:

- a. Discussion regarding the buildings at Oakdale Elementary (Gym and Community Center Room)

Direction provided to staff.

- b. Resolution to return funds from the short-term loan provided to 339D District Projects from the 339A General Fund

**Motion No. 2:** It was moved by Director M. Hanson and seconded by Director T. Dworetzky to adopt Resolution #2023-01 to return \$128, 406.61 of the original amounts of \$147, 427.55, that had been provided via a short-term inter-fund loan to provide cash flow to the Districts 339D District Projects account (reference original Resolution #2022-22).

**Motion Carried:** 4 Ayes, 0 Noes, 1 Absent, 0 Abstained

Ayes: A. Vassar, M. Hanson, S. Miller, T. Dworetzky

Absent: A. Gualderama

Abstained:

Vacant:

### 7. NEW BUSINESS:

- a. Discussion to enter into an agreement with Anderson Project Management Solutions

Direction provided to staff to enter into an agreement with Anderson Project Management Solutions, with the stipulation of “as not to exceed” amount.

- b. Prepare FY 2023-24 budget to include plans for the shop located at Hamilton Street Park

Director T. Dworetzky proposed, and the attending board members agreed that the first project for Anderson Project Management Solutions would be to provide options regarding the best approach to revamping/renovating the deteriorated shop building.

It was requested that Virg Anderson attend the June 2023 Board Meeting to provide and present proposed options for consideration.

## **MINUTES of Board of Directors Meeting**

April 20, 2023

Page 3 of 3

### **7. NEW BUSINESS: (cont.)**

- c.** Discuss 339I Impact fees and create a project to utilize the funds

For the May 2023 Board Meeting the GM will provide a list of projects that had previously been discussed and the board would review and prioritize for consideration, so that funds held in the 339I Impact Fees account could be utilized.

- d.** Update Policy 4030 Remuneration and Attendance

**Motion No. 3:** It was moved by Director M. Hanson and seconded by Director T. Dworetzky to approve the changes to Policy 4030 Remuneration and Attendance.

**Motion Carried:** 4 Ayes, 0 Noes, 1 Absent, 0 Abstained

Ayes: A. Vassar, M. Hanson, S. Miller, T. Dworetzky

Absent: A. Gualderama

Abstained:

Vacant:

### **8. BOARD DISCUSSION**

- a.** General discussion on topics for future meetings.

### **9. ADJOURNMENT OF THE MEETING.**

The chairperson adjourned the meeting at 7:51 pm.

**ACRPD 2022 - 2023  
339A Budget Report**

**April 2023  
Period 10 of 13**

**FYTD Completed = 77%**

	CODE	CATEGORIES	2022-23 Budget	April	Expended To Date	Balance	Percent Expended
1	10111000	Salaries and Wages - Reg F/T Staff	200,480.00	16,768.24	165,131.80	35,348.20	82%
2	"	<b>Part-time Salaries</b>			-		-0-
3	"	<b>P/T Monitors &amp; Maint.</b>	48,510.00	665.44	15,377.63	33,132.37	32%
4	"	<b>Blank</b>			-	-	#DIV/0!
5	"	<b>Blank</b>			-	-	#DIV/0!
6	"	<b>Blank</b>			-	-	#DIV/0!
7	10112400	Salaries & Wages - Commission & Brds	3,500.00	250.00	2,150.00	1,350.00	61%
8	10113200	Salaries & Wages - Time/one half (OT)	4,000.00	857.59	1,987.44	2,012.56	50%
9	"	Salary/Wages - Strt Time (No Retirement Contribution)		138.60	1,288.25	(1,288.25)	#DIV/0!
10	10121000	Retirement - Employer Cost (@10.32%)	11,824.00	991.69	9,742.47	2,081.53	82%
11	"	Retirement - Employer Cost (@8.63%)	7,414.00	617.82	6,105.33	1,308.67	82%
12	"	Retirement - <b>UAL</b> (110.08 mthly or 1277.00)	1,277.00		1,277.00	-	100%
13	"	Retirement Acturial Cost	1,000.00		350.00	650.00	35%
14	10122000	Social Security (OASDHI rate=7.65%)	19,622.00	1,429.03	14,224.04	5,397.96	72%
15	10123000	Group Insurance - Employer Cost			-	-	-0-
16	"	<b>Medical + Admin fee</b>	32,032.00	2,750.27	26,486.04	5,545.96	83%
17	"	<b>Dental</b>	1,516.00	125.37	1,384.83	131.17	91%
18	"	<b>Vision</b>	297.00	24.57	270.27	26.73	91%
19	"	<b>EAP</b>	131.00	26.10	104.40	26.60	80%
20	10124000	Work Comp Ins - Employer Cost	5,595.00		5,789.73	(194.73)	103%
21	10125000	State Unemployment Insurance (Pool)	1,000.00	10.65	463.03	536.97	46%
22	10128000	Health Care Retirees	1,914.00	153.80	1,595.65	318.35	83%
23	10140000	Cost Reduct Factor (CalPERS UAL Pre Pmt)			-	-	#DIV/0!
24		<b>TOTALS:</b>	<b>340,112.00</b>	<b>24,809.17</b>	<b>253,727.91</b>	<b>86,384.09</b>	<b>75%</b>

**ACRPD 2022 - 2023  
339A Budget Report**

**April 2023  
Period 10 of 13**

**FYTD Completed = 77%**

	CODE	Service & Supply	2022-23 Budget	April	Expended To Date	Balance	Percent Expended
25	20200500	Advertising/Legal Notices	200.00		174.52	25.48	87%
26	20202900	Business/Conference Expenses	2,000.00		426.39	1,573.61	21%
27	20203600	Education and Training Supplies	-		20.00	(20.00)	#DIV/0!
28	20203804	Workplace Amenities	-		958.47	(958.47)	#DIV/0!
29	20205100	Insurance - Liability	73,218.00		72,024.00	1,194.00	98%
30	20206100	Memberships Dues	5,500.00		6,056.00	(556.00)	110%
31	20207600	Office Supplies	1,500.00		737.56	762.44	49%
32	20207602	Signs	1,000.00		59.69	940.31	6%
33	20207603	Keys	200.00	15.09	15.09	184.91	8%
34	20208100	Postage Service (PO Box)	215.00		212.00	3.00	99%
35	20208102	Stamps (Postal)	150.00		-	150.00	0%
36	20208500	Printing Service	-		-	-	#DIV/0!
37	20210300	Agriculture/Horticultural Services	25,000.00	(13,950.00)	3,250.00	21,750.00	13%
38	20210400	Agricultural/Horticultural Supplies	500.00	6.43	403.57	96.43	81%
39	20211100	Building Maintenance Service	1,000.00	302.00	4,456.40	(3,456.40)	446%
40	20211200	Building Maintenance Supplies	500.00	39.86	41.01	458.99	8%
41	20212200	Chemical Supplies (new)	-		-	-	#DIV/0!
42	20213100	Electrical Maintenance Services	1,000.00		-	1,000.00	0%
43	20213200	Electrical Maintenance Supplies	200.00		-	200.00	0%
44	20214100	Land Improvement Maintenance Service	10,000.00	450.00	9,289.96	710.04	93%
45	20214200	Land Improvement Maintenance Sup.	5,000.00		867.49	4,132.51	17%
46	20215100	Mechanical System Maintenance Svcs.	2,000.00		1,167.00	833.00	58%
47	20215200	Mechanical System Maintenance Sup.	1,000.00		1,151.03	(151.03)	115%
48	20216200	Painting Supplies	1,500.00	208.28	782.62	717.38	52%
49	20216700	Plumbing Maintenance Service (new)	1,000.00	240.56	1,720.14	(720.14)	172%
50	20216800	Plumbing Maintenance Supplies	500.00		-	500.00	0%
51	20218500	Permit Charges	-		-	-	#DIV/0!
52	20219100	Electricity	20,000.00	1,028.45	13,726.11	6,273.89	69%



**ACRPD 2022 - 2023  
339A Budget Report**

**April 2023  
Period 10 of 13**

**FYTD Completed = 77%**

	CODE	Service & Supply	2022-23 Budget	April	Expended To Date	Balance	Percent Expended
53	20219200	Natural Gas Service	3,000.00	701.35	4,151.73	(1,151.73)	138%
54	20219300	Refuse Collection/Disposal	3,000.00	189.90	1,747.41	1,252.59	58%
55	20219500	Sewage Services	2,000.00	276.28	1,381.40	618.60	69%
56	20219800	Water	35,000.00	1,696.18	17,031.92	17,968.08	49%
57	20220500	Automotive Maintenance Service	3,500.00	1,494.72	2,005.47	1,494.53	57%
58	20220600	Automotive Maintenance Supplies	500.00	1,862.93	2,198.89	(1,698.89)	440%
59	20221100	Grounds Equipment Maintenance Svcs.	4,000.00		3,678.46	321.54	92%
60	20221200	Grounds Equipment Maintenance Sup.	4,000.00	80.53	5,685.39	(1,685.39)	142%
61	20222600	Hand / Expendable Tools	500.00	64.61	588.57	(88.57)	118%
62	20223600	Fuel and Lubricant Supplies	5,000.00	259.43	3,399.70	1,600.30	68%
63	20226200	Office Equip. Maintenance Supplies	1,000.00		1,665.78	(665.78)	167%
64	20227500	Rent/Lease Equipment	500.00		-	500.00	0%
65	20227501	Copy Machine - Lease	-		-	-	#DIV/0!
66	20227504	Miscellaneous	500.00		86.88	413.12	17%
67	20229100	Other Equip Maint. Service	2,000.00		-	2,000.00	0%
68	20229200	Other Equip Maint. Supply	2,000.00		-	2,000.00	0%
69	20231400	Clothing/Personal Supplies	100.00		308.25	(208.25)	308%
70	20232200	Custodial Supplies	6,000.00	283.65	4,415.67	1,584.33	74%
71	20243700	Lab (Medical) Service (Drug Testing)	100.00		-	100.00	0%
72	20244300	Medical Service (Pre-emp. testing)	200.00		168.00	32.00	84%
73	20244400	Medical Supplies (First Aid)	300.00		141.17	158.83	47%
74	20250605	Service Fees (Bank Loan Item)	-		-	-	#DIV/0!
75	20250700	Assessment / Collection Services	7,900.00	3,559.46	7,227.92	672.08	91%
76	20252100	Temporary Services	-		-	-	#DIV/0!
77	20253100	Legal Services	8,000.00	292.50	3,525.57	4,474.43	44%
78	20255100	Planning Service-	-		-	-	#DIV/0!
79	20257100	Security Service	25,000.00		6,863.78	18,136.22	27%
80	20258200	Public Relations Service/mkting, web	2,000.00		1,100.00	900.00	55%

**ACRPD 2022 - 2023  
339A Budget Report**

**April 2023  
Period 10 of 13**

**FYTD Completed = 77%**

	CODE	CATEGORIES	2022-23 Budget	April	Expended To Date	Balance	Percent Expended
81	20259100	Other Professional Services	-		14,090.00	(14,090.00)	#DIV/0!
82	20281100	Data Processing -Computer Services	2,500.00		108.00	2,392.00	4%
83	20281201	Hardware (Computer)	-		-	-	#DIV/0!
84	20281210	PC Laptop <b>Printer</b> (Copier) Purchase	-		-	-	#DIV/0!
85	20281265	Application Software Maint Lic Renewal	3,000.00	220.00	2,374.99	625.01	79%
86	20281304	Sales Tsx Adj - Board of EQ			-	-	#DIV/0!
87	20281700	Election Services	15,000.00		1,887.00	13,113.00	13%
88	20283102	Mileage	500.00	28.26	245.51	254.49	49%
89	20285100	Recreation Services	3,000.00		-	3,000.00	0%
90	20285200	Recreation Supplies	3,000.00		2,213.37	786.63	74%
91	20285300	Recreation Supp. (P-S) ELP Program			-	-	#DIV/0!
92	20288000	Prior Year Service & Supply Expe	-		-	-	#DIV/0!
93	20289800	Other Operating Expenses - Supplies	200.00		268.25	(68.25)	134%
94	20289900	Other Operating Exp. - Misc. expenses	200.00		183.87	16.13	-0-
95	20291300	Auditor/Controller Services	6,500.00		6,500.00	-	100%
96	20291500	Compass Costs	1,072.00		1,071.83	0.17	100%
97	20291700	Alarm Services	2,000.00	246.13	3,902.35	(1,902.35)	195%
98	20298700	Telephone Services	4,000.00	340.02	3,106.38	893.62	78%
99	20298701	Cell Phones	1,500.00	62.85	1,225.06	274.94	82%
100	20299909	Expenditure Reimbursements (Insurance Clair	20,000.00	13,950.00	33,895.77	(13,895.77)	169%
101		<b>TOTALS:</b>	<b>331,755.00</b>	<b>\$ 13,949.47</b>	<b>\$ 255,983.39</b>	<b>\$ 75,771.61</b>	<b>77%</b>

2059100 Other Prof Services - Expensed New Surveillance Cameras & Alarmed Rental Facility Buildings

20289800 Other Operating Expenses - Supplies - Also being used as an expence line for items that will be transferred to 339D via a JV

**ACRPD 2022 - 2023  
339A Budget Report**

**April 2023  
Period 10 of 13**

**FYTD Completed = 77%**

	CODE	CATEGORIES	2022-23 Budget	April	Expended To Date	Balance	Percent Expended
102	30321000	Interest Expense	7,191.00	558.42	6,640.92	550.08	92%
103	30323000	Lease Obligation Retirement(Side Fund)	30,400.00	2,600.00	27,800.00	2,600.00	91%
104	30345000	Taxes, Licenses & Assessments	704.00		703.64	0.36	100%
<b>TOTALS:</b>			<b>38,295.00</b>	<b>\$ 3,158.42</b>	<b>\$ 35,144.56</b>	<b>\$ 3,150.44</b>	<b>92%</b>

**FYTD Completed = 77%**

	CODE	CATEGORIES	2022-23 Budget	April	Expended To Date	Balance	Percent Expended
105	42420100	Building - Community Ctr Upgrades			-	-	#DIV/0!
106	43430300	Equipment SD Maint Equip			-	-	#DIV/0!
107	<b>TOTALS:</b>		<b>-</b>	<b>\$ -</b>	<b>\$ -</b>	<b>\$ -</b>	<b>#DIV/0!</b>

**FYTD Completed = 77%**

108	79790100	Contingencies	555,977.00		-	\$ 555,977.00	0%
109		Reserved Fund Balance Increase			-	\$ -	0%
110	<b>Grand Total</b>		<b>\$ 1,266,139.00</b>	<b>\$ 41,917.06</b>	<b>\$ 544,855.86</b>	<b>\$ 721,283.14</b>	<b>43%</b>

*Grand Total includes  
GL79790100 Contingencies  
amount*

	Beginning Fund Balance Available			-	\$ -	0%
	Fund Balance Decreased by				\$ -	0%
	Provisions for General Reserves		-	-	\$ -	0%
<b>TOTALS:</b>			<b>-</b>	<b>-</b>	<b>-</b>	<b>-</b>

**ACRPD 2022 - 2023**  
**339A Revenue**

**April 2023**  
**Period 10 of 13**

**FYTD Completed = 77%**  
**Percent Received**

<b>Account</b>		<b>2022-23 Budget</b>	<b>April</b>	<b>Received To Date</b>	<b>Unrealized</b>		
1	91910100	Property Tax-Current Secured	545,236.00	299,619.12	674,518.85	(129,282.85)	124%
2	91910200	Property Tax-Current Unsecured	23,000.00	744.35	23,083.65	(83.65)	100%
3	91910300	Property Tax-Current Sup.	17,000.00	3,952.29	18,663.22	(1,663.22)	110%
4	91910400	Property Tax Sec. Delin.(+Teeter)	5,000.00		4,123.09	876.91	82%
5	91910500	Property Tax Supplemental Delin.	900.00		1,575.62	(675.62)	175%
6	91910600	Property Tax-Unitary	6,000.00	3,332.48	6,956.84	(956.84)	116%
7	91912000	Redemption	100.00		75.54	24.46	76%
8	91913000	Property Tax Prior Unsecured	400.00	9.38	211.46	188.54	53%
9	91914000	Penalty	200.00	10.67	154.33	45.67	77%
10	91919600	RDA Residual Distribution	10,000.00		5,244.60	4,755.40	52%
11	91919900	Taxes - Other				-	#DIV/0!
12		<b>Total Taxes</b>	<b>\$ 607,836.00</b>	<b>\$ 307,668.29</b>	<b>734,607.20</b>	<b>\$ (126,771.20)</b>	<b>121%</b>
13	94941000	Interest	1,000.00	3,005.00	4,320.00	(3,320.00)	432%
14	94942900	Building Rental (Parks & Facilities)	10,001.00	410.00	5,090.00	4,911.00	51%
15	"	Building Rental (Cell Towers 4610.42)	55,325.00	4,610.42	46,104.20	9,220.80	83%
16	95952200	Homeowner Property Tax Relief	5,000.00	1849.28	4,491.11	508.89	90%
17	95952900	In Lieu Taxes - Other	-		-	-	#DIV/0!
18	95953300	Redevelopment Passthru	8,000.00		5,351.11	2,648.89	67%
19	95956300	State-Federal Grants			-	-	#DIV/0!
20	95956900	Other Funds - Local (GRANT)			-	-	#DIV/0!
21	"	<b>Grant = Park Sponsorships</b>			-	-	#DIV/0!
22	"	<b>Funds Transferred from 339I</b>			-	-	#DIV/0!
23	"	<b>Blank</b>			-	-	#DIV/0!
24	96964600	Recreation Fees			-	-	#DIV/0!
25	97974000	Insurance Proceeds	18,000.00	11,950.00	29,895.77	(11,895.77)	166%
26	97979000	Miscellaneous	5,000.00		42,208.07	(37,208.07)	844%
27	97979900	Prior Year (Funds moved to )			-	-	#DIV/0!
28	98986200	Proceeds from Asset sale - Spec Dist			-	-	#DIV/0!
29		Fund Balance Available =xxxxxxx.xx			-	-	#DIV/0!
30	<b>Problem</b>	**County Error In Process of Correction**	-		-	-	0%
31		<b>Total Other Revenue</b>	<b>\$ 102,326.00</b>	<b>\$ 21,824.70</b>	<b>\$ 137,460.26</b>	<b>\$ (35,134.26)</b>	<b>134%</b>
32		<b>Total Revenue</b>	<b>\$ 710,162.00</b>	<b>\$ 329,492.99</b>	<b>\$ 872,067.46</b>	<b>\$ (161,905.46)</b>	<b>123%</b>

Note: Per Resolution 2022-22 via JV 110777002, Short term loan of \$147,427.55 provided to 339D GL 5250000 by 339A GL 1800000

Note: Per Resolution 2023-01 via JV 110891191, Repaid Portion of Short term loan of \$128,406.61 provided to 339D GL 5250000 by 339A GL 1800000

**Register Expense Report**  
**Period 10**  
**Account**

**FY 2022-2023**  
**4/1/2023 Through 4/30/2023**  
**339A**

**Not  
Clrd**

Date	Num	Description	Memo	Category	Clrd	Amount
4/4/2023	24711	S CalPERS - 521	3/16 - 3/31/2023 EE Contrib	05420514 Retirement (EE Contribution)	c	(349.26)
			3/16 - 3/31/2023 ER Contrib	121000 Retirement ER Cost	c	(514.92)
4/4/2023	24712	S CalPERS - 521	3/16 - 3/31/2023 EE Contrib	05420514 Retirement (EE Contribution)	c	(250.56)
			3/16 - 3/31/2023 ER Contrib	121000 Retirement ER Cost	c	(308.91)
4/4/2023	24713	Central Control System - 23278	4/2023 - Wireless irrigation	281265 Application Software Maint. Lic	c	(220.00)
4/4/2023	24714	Cintas - 56036	3/29/2023 Custodial	232200 Custodial Supplies	c	(116.52)
4/4/2023	24715	Fast Break - 37998	3/2023 Phone service	298700 Telephone Services	c	(195.00)
4/4/2023	24716	S J&J Locksmith - 1833	4 / Keys	207603 Keys	c	(15.09)
			Labor, Trip Charge	211100 Building Maint. Service	c	(160.00)
			4 / Master pad locks	221200 Ground Equip Maint. Supplies	c	(80.53)
			Parts - Office door lock	211200 Building Maint. Supplies	c	(39.86)
4/4/2023	24717	Orbit Station - 33714	3/2023 - Fuel Chgs	223600 Fuel & Lubricant Supplies	c	(137.94)
4/4/2023	24718	PG&E - 1383	3/2023 - Billing	219200 Natural Gas Service	c	(701.35)
4/4/2023	24719	PRISM - 14746	4/2023 - 6/2023 - EAP Benefit - 3 EE's	123000 Health Insurance(s)	c	(26.10)
4/4/2023	24720	Republic Services - 57909	3/2023 - Billing	219300 Refuse Collection-Disposal	c	(189.90)
4/4/2023	24721	Rio Linda Fence - 57446	HSP - Repair fence shop yard	214100 Land Improvement Maint. Servic	c	(450.00)
4/4/2023	24722	Sacramento County utilities - 666	2/22 - 4/21/2023 - Billing	219500 Sewage Services	c	(276.28)
4/4/2023	24723	Sacramento Suburban Water - 26158	3/2023 Myrtle (Oak)	219800 Water	c	(805.27)
4/4/2023	24724	Sacramento Suburban Water - 26158	3/2023 HSP	219800 Water	c	(169.71)
4/4/2023	24725	S T-Mobile - 32685	3/2023 - District Cell Phone	298701 Cell Phones	c	(29.51)
			GM phone (purchase pmt)	298701 Cell Phones	c	(33.34)
4/11/2023	DepPermit	S County Of Sacramento Deposit Permit	Studio / Field Space	942900 Building Rental + Other	c	240.00
			Event Building / GPA / Park Rentals	942900 Building Rental + Other	c	170.00
			Cell Tower	942900 Building Rental + Other	c	4,610.42
			Grants -	956300 State - Federal Grants	c	-
			Misc Funds Collected / Received	979000 Misc Other Revenues	c	-
			Rental Refunds	942900 Building Rental + Other	c	-
4/11/2023	DepPermit	County Of Sacramento deposit Permit	HSP & ACP Ins Claim Dated 1/11/2023 - Windstorm D	974000 Insurance Proceeds	c	11,050.00
4/12/2023	24726	Cole Huber - 54641	1/2023 Ref:TRUSD Prop, Prepare & attend Brd mtg	253100 Legal Services	c	(292.50)
4/12/2023	24727	Comcast - 12322	4/2023 - Billing-Phone/HSI	298700 Telephone Services	c	(145.02)
4/12/2023	24728	Defender Termite & Pest - 71461	4/6/2023 - HSP Pest Control	211100 Building Maint. Service	c	(70.00)
4/12/2023	24729	Defender Termite & Pest - 71461	4/6/2023 - Oakdale RR Pest Control	211100 Building Maint. Service	c	(72.00)
4/12/2023	24730	S Home Depot - 2843	Wasp Spray	210400 Agricultural-Hort. Supplies	c	(6.43)
			2/Hoses	222600 Hand - Expendable Tools	c	(64.61)
			2 gal Sprayer	232200 Custodial Supplies	c	(50.61)

					Date Printed	5/4/2023
4/12/2023	24731	Home Depot - 2843	Paint supplies	216200	Painting Supplies	c (208.28)
4/12/2023	24732	Phillips 66 - 58398	4/2023 - Stmt	223600	Fuel & Lubricant Supplies	c (121.49)
4/12/2023	24733	Sacramento Control Systems - 1112	4/2023 - 6/30/2023 - AES Fire Monitoring (new rate)	291700	Alarm Services	c (246.13)
4/12/2023	24734	SMUD - 4025	3/2023 - SMUD Billing	219100	Electricity	c (1,028.45)
4/12/2023	JV	S # 110885414	Re-allocate to 299909 from 210300 C#24568	210300	Agriculture-Horticultural Service	c 2,700.00
			Re-allocate from 210300 to 299909 C#24568	299909	Expenditure Reimb. (Ins Claims)	c (2,700.00)
			Re-allocat to 299909 from 210300 C#24632	210300	Agriculture-Horticultural Service	c 2,000.00
			Re-allocate from 210300 to 299909 C#24632	299909	Expenditure Reimb. (Ins Claims)	c (2,000.00)
			Re-allocate to 299909 from 210300 C#24633	210300	Agriculture-Horticultural Service	c 1,800.00
			Re-allocate from 210300 to 299909 C#24633	299909	Expenditure Reimb. (Ins Claims)	c (1,800.00)
			Re-allocate to 299909 from 210300 C#24655	210300	Agriculture-Horticultural Service	c 600.00
			Re-allocate from 210300 to 299909 C#24655	299909	Expenditure Reimb. (Ins Claims)	c (600.00)
			Re-allocate to 299909 from 210300 C#24666	210300	Agriculture-Horticultural Service	c 6,850.00
			RE-allocate from 210300 to 299909 C#24666	299909	Expenditure Reimb. (Ins Claims)	c (6,850.00)
4/14/2023	P/R+Taxes	S Payroll And Taxes	Period 3/16/2023 - 3/31/2023- Ck date 4/14/2023	111000	Salaries & Wages	c (8,935.11)
			Brd Pay Ck date 4/14/2023	112400	Stipend Commission & Board	c (250.00)
			Time/One Half - Ck date 4/14/2023	113200	OT & Straight Time	c (476.44)
			OT Straight Pay - Ck date 4/14/2023	113200	OT & Straight Time	c (138.60)
			OASDHI - Ck date 4/14/2023	122000	OASDHI	c (749.72)
			SUI ER Contrib Ck date 4/14/2023	125000	SUI Insurance (ER Cost)	c (5.86)
			Termination Pay	115200	Terminal Pay	c -
4/14/2023	EFT	# 400044661 - Health Benefits	Health Benefits Pay Date 4/14/2023	123000	Health Insurance(s)	c (1,370.61)
4/18/2023	DepPermit	County Of Sacramento deposit Permit	HSP & ACP Ins Claim Dated 1/11/2023- Windstorm D:	974000	Insurance Proceeds	c 900.00
4/20/2023	24735	S CalPERS - 521	4/1 - 4/15/2023 EE Contrib	05420514	Retirment (EE Contribution)	c (323.39)
			4/1 - 4/15/2023 ER Contrib	121000	Retirement ER Cost	c (476.77)
4/20/2023	24736	S CalPERS - 521	4/1 - 4/15/2023 EE Contrib	05420514	Retirment (EE Contribution)	c (250.56)
			4/1 - 4/15/2023 ER Contrib	121000	Retirement ER Cost	c (308.91)
4/20/2023	24737	Cintas - 56036	4/12/2023 - Custodial	232200	Custodial Supplies	c (116.52)
4/20/2023	24738	S GSRMA - 29229	5/2023 - Dental - 3 EEs	123000	Health Insurance(s)	c (125.37)
			5/2023 -Vision - 3 EEs	123000	Health Insurance(s)	c (24.57)
4/20/2023	24739	S OK Tire - 14277	Labor - 2010 Ford	220500	Automotive Maint. Service	c (1,494.72)
			Parts - 2010 Ford - Tire Sensor	220600	Automotive Maint. Supplies	c (1,862.93)
4/20/2023	24740	Sacramento Suburban Water - 26158	4/2023 Garfield (ACP)	219800	Water	c (721.20)
4/24/2023	EFT	Assessment/Collection Service	SB 2557 2nd Installment	250700	Assessment - Collection Services	c (3,559.46)
4/25/2023	24741	S CalPERS Health - 12733	5/2023 - Medical - 3 EE's	5420516	Insurance (Clearing Acct)	c (2,741.22)
			5/2023 - Medical - EE Admin Fee	123000	Health Insurance(s)	c (9.05)
			5/2023- Medical - 2 Retirees	128000	Retiree Health Benefits	c (153.80)
4/25/2023	24742	Kim Cook - 919996	4/2023 - Mileage Reimb	283102	Mileage	c (28.26)
4/25/2023	24743	S Umpqua Bank - 52152	5/2023 - Side Fund Interest	321000	Interest Expense	c (558.42)
			5/2023 - Side Fund Principal	323000	Lease Oblig Retirement Side Fur	c (2,600.00)
4/28/2023	P/R+Taxes	S Payroll And Taxes	Period 4/1/2023 - 4/15/2023- Ck date 4/28/2023	111000	Salaries & Wages	c (8,498.57)
			Brd Pay Ck date 4/28/2023	112400	Stipend Commission & Board	c -

		Date Printed	5/4/2023
	Time/One Half - Ck date 4/28/2023	113200 OT & Straight Time	c (381.15)
	OT Straight Pay - Ck date 4/28/2023	113200 OT & Straight Time	c -
	OASDHI - Ck date 4/28/2023	122000 OASDHI	c (679.31)
	SUI ER Contrib Ck date 4/28/2023	125000 SUI Insurance (ER Cost)	c (4.79)
	Termination Pay	115200 Terminal Pay	c -
4/28/2023 EFT	# 400044765 - Health Benefits	123000 Health Insurance(s)	c (1,370.61)
4/28/2023 TaxRevenu	S Property Tax(s) Deposited Per County C	910100 Prop Tax Current Secured	c 299,619.12
	4/2023 - Property Tax - Current Secured	910200 Prop Tax Current Unsecured	c 744.35
	4/2023 - Property Tax - Current Unsecured	910300 Prop Tax Current Sup	c 3,952.29
	4/2023 - Property Tax - Current Sup.	910400 Prop Tax Sec Delinquent + Teets	c 3,332.48
	4/2023 - Property Tax Sec Delin.(+Tetter)	910500 Prop Tax Supplemental Delinque	c -
	4/2023 - Property Tax Supplement Delin.	910600 Prop Tax Unitary	c -
	4/2023 - Properry Tax-Unitary	912000 Prop Tax Redemption	c -
	4/2023 - Redemption	913000 Prop Tax Prior Unsecured	c 9.38
	4/2023 - Property Tax Prior Unsecured	914000 Prop Tax Penalties	c 10.67
	4/2023 - Penalty	919600 RDA Residual Distribution	c -
	4/2023 - RDA Residual Distribution	941000 Interest	c 3,005.00
	4/2023 - Interest	952200 Homeowner Prop Tax Relief	c 1,849.28
	4/2023 - Homeowner Property Tax Relief	953300 Redevelopment Passthru	c -
	4/2023 - Redevelopment Passthru	919900 Taxes Other	c -
	4/2023 -Taxes Other		
		<b>TOTAL 4/1/2023 - 4/30/2023</b>	283,901.50
		<b>BALANCE 4/30/2023</b>	286,519.21
		<b>TOTAL INFLOWS</b>	343,442.99
		<b>TOTAL OUTFLOWS</b>	(59,541.49)
		<b>NET TOTAL</b>	283,901.50

Quicken (In House Ledger)

339A General Budget

7/1/2022 thru 4/30/2023

Date	Num	Description	Memo	Clr	Amount
<b>EXPENSES</b>					
200500 Advertising - Legal Notices					
1/4/2023	24618	S Umpqua CC - 71085	2023 EE Poster & Pamphlets	c	(174.52)
<b>TOTAL 200500 Advertising - Legal Notices</b>					(174.52)
202900 Business Conference Expenses					
12/2/2022	24572	S Umpqua CC - 71085	11/5/2022 Board Retreat Lunch	c	(114.03)
3/6/2023	24695	S Umpqua CC - 71085	2023 CARPD Conference - Gonzalez	c	(312.36)
<b>TOTAL 202900 Business Conference Expenses</b>					(426.39)
203600 Education & Training Supplies					
11/3/2022	24532	S Umpqua CC - 71085	CSDA Brown Act Compliance Manual 2nd Edition	c	(20.00)
<b>TOTAL 203600 Education &amp; Training Supplies</b>					(20.00)
203804 Workplace Amenities					
11/14/2022	24539	S Home Depot - 2843	Microwave (office)	c	(224.12)
12/2/2022	24559	S Home Depot - 2843	GE Fridge - Office	c	(644.35)
			Protection Plan 3 yr GE Fridge	c	(90.00)
<b>TOTAL 203804 Workplace Amenities</b>					(958.47)
205100 Insurance - Liability					
7/12/2022	24379	CAPRI - 8761	7/2022-6/2023 -1st half Liability Ins Coverage	c	(36,012.00)
12/8/2022	24574	CAPRI - 8761	7/2022-6/2023 -2nd half Liability Ins Coverage	c	(36,012.00)
<b>TOTAL 205100 Insurance - Liability</b>					(72,024.00)
206100 Membership Dues					
7/12/2022	24377	CARPD - 70968	FY 2022-23 Dues	c	(2,500.00)
9/7/2022	24458	S Umpqua CC - 71085	1 Yr Memberhsip - CPRS L Gonzalez	c	(165.00)
12/2/2022	24557	CSDA - 8529	2023 - Membership Dues	c	(3,391.00)
<b>TOTAL 206100 Membership Dues</b>					(6,056.00)
207600 Office Supplies					
7/20/2022	24397	Staples Business Advantage - 14122	Office supplies	c	(179.07)
7/26/2022	24405	Staples Business Advantage - 14122	Office supplies	c	(75.26)
10/20/2022	24514	Staples Business Advantage - 14122	Office supplies	c	(108.22)
11/3/2022	24532	S Umpqua CC - 71085	Office ink stamps	c	(24.53)



1/4/2023	24615	Staples Business Advantage - 14122	Office supplies	c	(54.38)
1/4/2023	24616	Staples Business Advantage - 14122	Office supplies	c	(60.00)
1/25/2023	24641	Staples Business Advantage - 14122	Office supplies - inc 4 cases copy paper	c	(208.11)
2/15/2023	24669	Staples Business Advantage - 14122	2/ reams 8.5x14 copy paper	c	(27.99)
			<b>TOTAL 207600 Office Supplies</b>		<b>(737.56)</b>
207602 Signs					
8/10/2022	24424	S Umpqua CC - 71085	Private Property Signs	c	(32.31)
11/14/2022	24539	S Home Depot - 2843	No Trespassing signs	c	(11.22)
			<b>TOTAL 207602 Signs</b>		<b>(43.53)</b>
207603 Keys					
10/24/2022	24515	S J&J Locksmith - 1833	Keys	c	(16.16)
4/4/2023	24716	S J&J Locksmith - 1833	4 / Keys	c	(15.09)
			<b>TOTAL 207603 Keys</b>		<b>(31.25)</b>
208100 Postage Service (PO Box)					
8/10/2022	24424	S Umpqua CC - 71085	1 Yr District Postal Box	c	(212.00)
			<b>TOTAL 208100 Postage Service (PO Box)</b>		<b>(212.00)</b>
210300 Agriculture-Horticultural Service					
7/5/2022	24364	Dave Weber - 54010	ACP trail / Oak Remove playground partl	c	(850.00)
10/13/2022	24503	Raul's Tree Care - 69419	HSP Removal split Valley Oak/ clean up utility lines near office	c	(1,500.00)
10/13/2022	24504	Raul's Tree Care - 69419	ACP Remove 3 dead Valley Oaks/Street clearance on parking l	c	(900.00)
12/2/2022	24568	Raul's Tree Care - 69419	HSP Stump grinding 19 various sizes	c	(2,700.00)
1/17/2023	24632	Raul's Tree Care - 69419	HSP Removal 2 trees	c	(2,000.00)
1/17/2023	24633	Raul's Tree Care - 69419	ACP - Clear trail	c	(1,800.00)
2/15/2023	24665	Raul's Tree Care - 69419	HSP - Chip brush	c	(600.00)
2/15/2023	24666	S Raul's Tree Care - 69419	ACP Trail - Clear trees & brush	c	(5,000.00)
			ACP - 2 Eucalyptus trees	c	(1,600.00)
			ACP - Eucalyptus (remove from neighbors yard)	c	(250.00)
4/12/2023	JV	S # 110885414	Re-allocate to 299909 from 210300 C#24568	c	2,700.00
			Re-allocat to 299909 from 210300 C#24632	c	2,000.00
			Re-allocate to 299909 from 210300 C#24633	c	1,800.00
			Re-allocate to 299909 from 210300 C#24655	c	600.00
			Re-allocate to 299909 from 210300 C#24666	c	6,850.00
			<b>TOTAL 210300 Agriculture-Horticultural Service</b>		<b>(3,250.00)</b>
210400 Agricultural-Hort. Supplies					

3/15/2023	24702	S	Normac - 1309	2/ 2.5 gal Round Up Promax	c	(397.14)
4/12/2023	24730	S	Home Depot - 2843	Wasp Spray	c	(6.43)
<b>TOTAL 210400 Agricultural-Hort. Supplies</b>						<b>(403.57)</b>

211100 Building Maint. Service

7/25/2022	24399		Defender Termite & Pest - 71461	7/2022 - HSP Pest Control	c	(70.00)
7/25/2022	24400		Defender Termite & Pest - 71461	7/2022 - Oakdale RR Pest Control	c	(72.00)
8/2/2022	24413		Restoration Landscape - 71858	HSP Vandalism 7/20/2022 -Shore broken window Sm Rm	c	(495.00)
8/2/2022	24414		Restoration Landscape - 71858	HSP Vandalism 8/1/2022 -Shore upper window @ shop	c	(1,025.00)
9/7/2022	24456		Southgate Glass, Inc / Carmichael - 5461	Replace window HSP Sm Rm Vandalism 7/20/2022	c	(677.40)
9/26/2022	24474		Defender Termite & Pest - 71461	9/2022 - HSP Pest Control	c	(70.00)
9/26/2022	24475		Defender Termite & Pest - 71461	9/2022 -Oakdale RR Pest Control	c	(72.00)
12/15/2022	24584		Defender Termite & Pest - 71461	12/2022 - HSP Pest Control	c	(70.00)
12/15/2022	24585		Defender Termite & Pest - 71461	12/2022 - Oakdale RR Pest Control	c	(72.00)
12/15/2022	24588		Sacramento Valley Wildlife Services - 65804	Placement Skunk Trap @ HSP	c	(245.00)
12/15/2022	24589		Sacramento Valley Wildlife Services - 65804	Skunk Removal	c	(125.00)
1/10/2023	24625	S	Sacramento Valley Wildlife Services - 65804	7 Skunk removals	c	(875.00)
				Mthly trap charge	c	(19.00)
2/15/2023	24661		Defender Termite & Pest - 71461	2/2/2023 - HSP Pest Control	c	(70.00)
2/15/2023	24662		Defender Termite & Pest - 71461	2/2/2023 - Oakdale RR Pest Control	c	(72.00)
3/6/2023	24693		Sacramento Valley Wildlife Services - 65804	Opossum Removal	c	(125.00)
4/4/2023	24716	S	J&J Locksmith - 1833	Labor, Trip Charge	c	(160.00)
4/12/2023	24728		Defender Termite & Pest - 71461	4/6/2023 - HSP Pest Control	c	(70.00)
4/12/2023	24729		Defender Termite & Pest - 71461	4/6/2023 - Oakdale RR Pest Control	c	(72.00)
<b>TOTAL 211100 Building Maint. Service</b>						<b>(4,456.40)</b>

211200 Building Maint. Supplies

9/26/2022	24477		Home Depot - 2843	HSP - Lighting Fixtures - Main Office	c	(180.35)
2/6/2023	24657		Umpqua CC - 71085	1/2023 Stmt	c	(1.15)
3/6/2023	24695	S	Umpqua CC - 71085	Time Switch Mechanism	c	(91.46)
4/4/2023	24716	S	J&J Locksmith - 1833	Parts - Office door lock	c	(39.86)
<b>TOTAL 211200 Building Maint. Supplies</b>						<b>(312.82)</b>

214100 Land Improvement Maint. Services

7/12/2022	24376		Carson Landscape Indus. - 18136	HSP Irrigation repair- Rotors	c	(870.00)
8/2/2022	24415		Rio Linda Fence - 57446	ACP Welded bolts solar light base on 14 light poles	c	(675.00)
9/7/2022	24443		Carson Landscape Indus. - 18136	HSP Irrigation repair- Valve	c	(2,900.00)
11/3/2022	24527		Rio Linda Fence - 57446	HSP - Repair fence near soccer field (fire dept damage)	c	(450.00)
12/20/2022	24601	S	Dave Weber - 54010	Post Removal @ HSP	c	(550.00)

1/4/2023	24613	S	Restoration Landscape - 71858	Demolished Concrete Picnic Tables @ HSP	c	(1,500.00)
				Back fill post holes @ HSP	c	(650.00)
1/4/2023	24618	S	Umpqua CC - 71085	Dump fee - remaining concrete form bollard removal	c	(115.00)
4/4/2023	24721		Rio Linda Fence - 57446	Concrete Disposal from Bollard Removal @ HSP	c	(1,129.96)
				HSP - Repair fence shop yard	c	(450.00)
				<b>TOTAL 214100 Land Improvement Maint. Services</b>		<b>(9,289.96)</b>
<b>214200 Land Improvement Maint. Supplies</b>						
7/12/2022	24383		Home Depot - 2843	Irrigation Supply	c	(17.68)
7/12/2022	24384		Normac - 1309	Irrigation supplies - 12 Rotors	c	(474.39)
9/26/2022	24476		Home Depot - 2843	ACP - Dog Park Sand	c	(35.36)
3/15/2023	24702	S	Normac - 1309	Irrigation supplies - 8 rotors	c	(340.06)
				<b>TOTAL 214200 Land Improvement Maint. Supplies</b>		<b>(867.49)</b>
<b>215100 Mechanical Sys Maint. Services</b>						
7/20/2022	24392		Clarke & Rusch - 8939	7/11/2022 Planned Maint.	c	(229.00)
8/15/2022	24425		All Pro Backflow - 69926	Backflow test @ ACP 2	c	(160.00)
8/15/2022	24426		All Pro Backflow - 69926	Backflow test @ Oak 4	c	(320.00)
12/15/2022	24580		Clarke & Rusch - 8939	11/8/2022 Planned Maint.	c	(229.00)
1/25/2023	24635		Clarke & Rusch - 8939	1/19/2023 Planned Maint.	c	(229.00)
				<b>TOTAL 215100 Mechanical Sys Maint. Services</b>		<b>(1,167.00)</b>
<b>215200 Mechanical Sys Maint. Supplies</b>						
8/10/2022	24424	S	Umpqua CC - 71085	Safety Cabinet (Fuel Storage)	c	(1,151.03)
				<b>TOTAL 215200 Mechanical Sys Maint. Supplies</b>		<b>(1,151.03)</b>
<b>216200 Painting Supplies</b>						
12/2/2022	24561	S	Home Depot - 2843	Paint Supplies	c	(176.29)
				2% Prompt pmt discount	c	3.27
3/6/2023	24689		Home Depot - 2843	Paint Supplies (ref claim #24561) repmt of 2% credit	c	(3.27)
3/15/2023	24705		SnagWolf - 61550	Safety Two Graffiti Remover 1 case	c	(398.05)
4/12/2023	24731		Home Depot - 2843	Paint supplies	c	(208.28)
				<b>TOTAL 216200 Painting Supplies</b>		<b>(782.62)</b>
<b>216700 Plumbing Maint. Service</b>						
10/13/2022	24499		Clarke & Rusch - 8939	Plumbing Service HSP Public RR (mens)	c	(399.20)
11/22/2022	24551		America's Plumbing - 70141	Plumbing Service HSP Public RR (mens)	c	(279.49)
2/21/2023	24670		America's Plumbing - 70141	Plumbing Service HSP Office	c	(800.89)
3/22/2023	24706		America's Plumbing - 70141	Plumbing Service HSP Rental RR's	c	(240.56)

**TOTAL 216700 Plumbing Maint. Service** (1,720.14)

219100 Electricity

7/12/2022	24388 SMUD - 4025	6/2022 - SMUD Billing	c	(1,486.78)
8/10/2022	24423 SMUD - 4025	7/2022 - SMUD Billing	c	(2,352.09)
9/7/2022	24455 SMUD - 4025	8/2022 - SMUD Billing	c	(1,836.85)
10/13/2022	24505 SMUD - 4025	9/2022 - SMUD Billing	c	(1,516.91)
11/14/2022	24542 SMUD - 4025	10/2022 - SMUD Billing	c	(1,277.02)
12/8/2022	24578 SMUD - 4025	11/2022 - SMUD Billing	c	(1,074.16)
1/10/2023	24626 SMUD - 4025	12/2022 - SMUD Billing	c	(1,007.68)
2/15/2023	24668 SMUD - 4025	1/2023 - SMUD Billing	c	(1,060.44)
3/15/2023	24704 SMUD - 4025	2/2023 - SMUD Billing	c	(1,085.73)
4/12/2023	24734 SMUD - 4025	3/2023 - SMUD Billing	c	(1,028.45)
<b>TOTAL 219100 Electricity</b>				<b>(13,726.11)</b>

219200 Natural Gas Service

7/5/2022	24369 PG&E - 1383	6/2022 - Billing	c	(15.63)
8/2/2022	24411 PG&E - 1383	7/2022 - Billing	c	(16.68)
9/7/2022	24452 PG&E - 1383	8/2022 - Billing	c	(15.64)
10/4/2022	24488 PG&E - 1383	9/2022 - Billing	c	(15.63)
11/3/2022	24525 PG&E - 1383	10/2022 - Billing	c	(18.00)
12/2/2022	24567 PG&E - 1383	11/2022 - Billing	c	(460.99)
1/4/2023	24610 PG&E - 1383	12/2022 - Billing	c	(895.63)
2/6/2023	24653 PG&E - 1383	1/2023 - Billing	c	(1,008.05)
3/6/2023	24691 PG&E - 1383	2/2023 - Billing	c	(1,004.13)
4/4/2023	24718 PG&E - 1383	3/2023 - Billing	c	(701.35)
<b>TOTAL 219200 Natural Gas Service</b>				<b>(4,151.73)</b>

219300 Refuse Collection-Disposal

7/20/2022	24395	S	Republic Services - 57909	6/2022 Billing	c	(342.19)
				CREDIT - Billed in error Organics Waste	c	152.29
8/2/2022	24412	S	Republic Services - 57909	7/2022 Billing	c	(289.90)
				CREDIT - Billed in error Organics Waste	c	100.00
9/7/2022	24453	S	Republic Services - 57909	8/2022 Billing	c	(289.90)
				7/26/2022 Overage Charge	c	(88.00)
				Deduction Billing error for Organic Waste	c	100.00
11/3/2022	24526	S	Republic Services - 57909	Credit from 9/2022 billing	c	2.28
				10/2022 Billing	c	(189.90)
12/8/2022	24576		Republic Services - 57909	11/2022 - Billing	c	(189.90)

1/4/2023	24612	Republic Services - 57909	12/2022 - Billing	c	(189.90)
2/6/2023	24654	S Republic Services - 57909	1/2023 - Billing	c	(189.90)
			Credit 1/2023 Yard Waste	c	47.41
3/6/2023	24692	Republic Services - 57909	2/2023 - Billing	c	(189.90)
4/4/2023	24720	Republic Services - 57909	3/2023 - Billing	c	(189.90)
<b>TOTAL 219300 Refuse Collection-Disposal</b>					<b>(1,747.41)</b>

219500 Sewage Services

8/2/2022	24416	Sacramento County utilities - 666	6/22 -8/21/2022- Billing	c	(276.28)
10/4/2022	24493	Sacramento County utilities - 666	8/22 -10/21/2022- Billing	c	(276.28)
12/8/2022	24577	Sacramento County utilities - 666	10/22 -12/21/2022- Billing	c	(276.28)
2/6/2023	24655	Sacramento County utilities - 666	12/22 - 2/21/2023 - Billing	c	(276.28)
4/4/2023	24722	Sacramento County utilities - 666	2/22 - 4/21/2023 - Billing	c	(276.28)
<b>TOTAL 219500 Sewage Services</b>					<b>(1,381.40)</b>

219800 Water

7/20/2022	24396	Sacramento Suburban Water - 26158	7/2022 - Garfield (ACP)	c	(1,157.52)
7/26/2022	24403	Sacramento Suburban Water - 26158	7/2022 - Myrtle (Oak)	c	(746.12)
7/26/2022	24404	Sacramento Suburban Water - 26158	7/2022 - HSP	c	(146.19)
8/23/2022	24437	Sacramento Suburban Water - 26158	8/2022 - Garfield (ACP)	c	(1,356.32)
8/23/2022	24438	Sacramento Suburban Water - 26158	8/2022 - Myrtle (Oak)	c	(1,613.74)
8/23/2022	24439	Sacramento Suburban Water - 26158	8/2022 - HSP	c	(149.03)
9/21/2022	24473	Sacramento Suburban Water - 26158	9/2022 - Garfield (ACP)	c	(975.76)
10/4/2022	24494	Sacramento Suburban Water - 26158	9/2022 - Myrtle (Oak)	c	(801.50)
10/4/2022	24495	Sacramento Suburban Water - 26158	9/2022 - HSP	c	(151.87)
10/20/2022	24513	Sacramento Suburban Water - 26158	10/2022 - Garfield (ACP)	c	(852.22)
11/3/2022	24528	Sacramento Suburban Water - 26158	10/2022 - Myrtle (Oak)	c	(763.16)
11/3/2022	24529	Sacramento Suburban Water - 26158	10/2022 - HSP	c	(149.03)
11/21/2022	24550	Sacramento Suburban Water - 26158	11/2022 - Garfield (ACP)	c	(825.24)
12/2/2022	24569	Sacramento Suburban Water - 26158	11/2022 - Myrtls (Oak)	c	(840.90)
12/2/2022	24570	Sacramento Suburban Water - 26158	11/2022 - HSP	c	(169.61)
12/15/2022	24587	Sacramento Suburban Water - 26158	12/2022 - Garfield (ACP)	c	(724.42)
12/20/2022	24595	Sacramento Suburban Water - 26158	12/2022 - Myrtle (Oak)	c	(947.76)
12/20/2022	24596	Sacramento Suburban Water - 26158	12/2022 - HSP	c	(160.39)
1/25/2023	24638	S Sacramento Suburban Water - 26158	1/2023 - Garfield (ACP)	c	(450.72)
			Credit Overread Useage	c	282.58
1/25/2023	24639	S Sacramento Suburban Water - 26158	1/2023 - Myrtle (Oak)	c	(783.22)
			Credit Overread Useage	c	191.70
1/25/2023	24640	Sacramento Suburban Water - 26158	1/2023 - HSP	c	(171.18)

2/15/2023	24667	Sacramento Suburban Water - 26158	2/2023 Garfield (ACP)	c	(473.41)
2/22/2023	24680	Sacramento Suburban Water - 26158	2/2023 Myrtle (Oak)	c	(784.69)
2/22/2023	24681	Sacramento Suburban Water - 26158	2/2023 HSP	c	(165.30)
3/15/2023	24703	Sacramento Suburban Water - 26158	3/2023 Garfield (ACP)	c	(450.72)
4/4/2023	24723	Sacramento Suburban Water - 26158	3/2023 Myrtle (Oak)	c	(805.27)
4/4/2023	24724	Sacramento Suburban Water - 26158	3/2023 HSP	c	(169.71)
4/20/2023	24740	Sacramento Suburban Water - 26158	4/2023 Garfield (ACP)	c	(721.20)
				<b>TOTAL 219800 Water</b>	<b>(17,031.92)</b>

220500 Automotive Maint. Service

9/21/2022	24472	S OK Tire - 14277	Labor - 1996 Chevy -Charging System, 2 Mirrors	c	(470.85)
12/2/2022	24565	S OK Tire - 14277	Labor - 2010 Ford	c	(39.90)
4/20/2023	24739	S OK Tire - 14277	Labor - 2010 Ford	c	(1,494.72)
				<b>TOTAL 220500 Automotive Maint. Service</b>	<b>(2,005.47)</b>

220600 Automotive Maint. Supplies

9/21/2022	24472	S OK Tire - 14277	Parts - 1996 Chevy - 2 Mirrors	c	(142.12)
12/2/2022	24565	S OK Tire - 14277	Parts - 2010 Ford - Tire Sensor	c	(193.84)
4/20/2023	24739	S OK Tire - 14277	Parts - 2010 Ford - Tire Sensor	c	(1,862.93)
				<b>TOTAL 220600 Automotive Maint. Supplies</b>	<b>(2,198.89)</b>

221100 Grounds Equip Maint. Services

7/12/2022	24385	S PAPE - 18032	Labor - J Deere 2011 Z920	c	(667.20)
7/25/2022	EFT	S Sacramento For Tractors - 64608	Ref Claim 23831 (correcting entry)	c	302.50
9/7/2022	24454	S Sacramento For Tractors - 64608	Labor Repairs - Kubota	c	(1,170.00)
2/15/2023	24664	S PAPE - 18032	Labor - J Deere 2011 Z920	c	(1,214.07)
2/21/2023	24678	S PAPE - 18032	Labor - J Deere 2021 Z9974 Mower	c	(929.69)
				<b>TOTAL 221100 Grounds Equip Maint. Services</b>	<b>(3,678.46)</b>

221200 Ground Equip Maint. Supplies

7/12/2022	24385	S PAPE - 18032	Repair Parts - J Deere 2011 Z920	c	(766.51)
7/12/2022	24386	PAPE - 18032	Parts filters - J Deere 2021 Z997	c	(60.40)
7/25/2022	EFT	S Sacramento For Tractors - 64608	Ref Claim 23831 (correcting entry)	c	294.56
8/10/2022	24422	J&J Locksmith - 1833	HSP - repair locks	c	(218.19)
9/7/2022	24454	S Sacramento For Tractors - 64608	Repair Parts - Kubota	c	(1,419.94)
9/21/2022	24465	S Bar-Hein Co. - 1463	2 Trimmer heads	c	(78.20)
10/24/2022	24515	S J&J Locksmith - 1833	3/Locks, Tri Flow	c	(86.96)
12/2/2022	24560	Home Depot - 2843	2/Circular saw blades	c	(107.73)
1/25/2023	24637	J&J Locksmith - 1833	ACP - Repair RR lock	c	(111.00)

2/15/2023	24664	S	PAPE - 18032	Repair Parts - J Deere 2011 Z920	c	(2,510.28)
2/21/2023	24678	S	PAPE - 18032	Repair Parts - J Deere 2021 Z9974 Mower	c	(215.90)
3/15/2023	24696	S	Bar-Hein Co. - 1463	Trimmer heads, Air Filter, spark plug	c	(52.50)
4/4/2023	24716	S	J&J Locksmith - 1833	4 / Master pad locks	c	(80.53)
<b>TOTAL 221200 Ground Equip Maint. Supplies</b>						<b>(5,413.58)</b>

222600 Hand - Expendable Tools

8/10/2022	24424	S	Umpqua CC - 71085	Maint. Tools	c	(27.83)
44,825.00	24465	S	Bar-Hein Co. - 1463	30" Loppers / 4 Tarps	c	(85.12)
9/21/2022	24471	S	Home Depot - 2843	Power Saw & Drill, asst tools	c	(321.65)
1/10/2023	24623	S	Home Depot - 2843	2/Lg Tarps	c	(68.91)
3/15/2023	24696	S	Bar-Hein Co. - 1463	Rake, Gloves	c	(20.45)
4/12/2023	24730	S	Home Depot - 2843	2/Hoses	c	(64.61)
<b>TOTAL 222600 Hand - Expendable Tools</b>						<b>(588.57)</b>

223600 Fuel & Lubricant Supplies

7/5/2022	24368		Orbit Station - 33714	6/2022- Fuel Chgs	c	(582.87)
7/12/2022	24387		Phillips 66 - 58398	6/2022 - Stmt	c	(39.99)
8/2/2022	24410		Orbit Station - 33714	7/2022- Fuel Chgs	c	(201.61)
8/15/2022	24429		Phillips 66 - 58398	7/2022 - Stmt	c	(258.60)
9/7/2022	24451		Orbit Station - 33714	8/2022- Fuel Chgs	c	(225.92)
9/21/2022	24471	S	Home Depot - 2843	4 Grease Cartridges	c	(19.27)
10/13/2022	24502		Orbit Station - 33714	9/2022- Fuel Chgs	c	(200.00)
11/3/2022	24524		Orbit Station - 33714	10/2022- Fuel Chgs	c	(134.53)
11/14/2022	24541		Phillips 66 - 58398	10/2022 - Stmt	c	(368.20)
12/2/2022	24566		Orbit Station - 33714	11/2022- Fuel Chgs	c	(220.20)
1/10/2023	24624		Orbit Station - 33714	12/2022- Fuel Chgs	c	(234.22)
1/17/2023	24631		Hunt & Sons - 1306	12- 10w30 oil / 1- 5 gal Well pump oil	c	(272.00)
2/6/2023	24652		Orbit Station - 33714	1/2023 - Fuel Chgs	c	(220.69)
3/6/2023	24690		Orbit Station - 33714	2/2023 - Fuel Chgs	c	(146.01)
3/15/2023	24696	S	Bar-Hein Co. - 1463	6 pk/ 5.2 oz oil	c	(16.16)
4/4/2023	24717		Orbit Station - 33714	3/2023 - Fuel Chgs	c	(137.94)
4/12/2023	24732		Phillips 66 - 58398	4/2023 - Stmt	c	(121.49)
<b>TOTAL 223600 Fuel &amp; Lubricant Supplies</b>						<b>(3,399.70)</b>

226200 Office Equip Maint Supplies

9/7/2022	24447		Encompass - 18796	Toner - Blk	c	(215.49)
9/7/2022	24448		Encompass - 18796	Copier - Replaced Transfer Belt	c	(297.38)
1/10/2023	24622		Encompass - 18796	Toner - All Colors	c	(1,152.91)

**TOTAL 226200 Office Equip Maint Supplies (1,665.78)**

227504 Misc (Bottled Water for Staff)

9/26/2022	24478	S	Smart & Final - 22935	8 cases water for staff	c	(57.92)
12/15/2022	24590	S	Smart & Final - 22935	4 cases water for staff	c	(28.96)
<b>TOTAL 227504 Misc (Bottled Water for Staff)</b>						<b>(86.88)</b>

231400 Clothing - Personal Supplies

11/3/2022	24523	S	Home Depot - 2843	Staff Safety & Rain Gear	c	(73.68)
12/2/2022	24572	S	Umpqua CC - 71085	Staff shirts	c	(234.57)
<b>TOTAL 231400 Clothing - Personal Supplies</b>						<b>(308.25)</b>

232200 Custodial Supplies

7/12/2022	24380		Cintas - 56036	7/8/2022 Custodial	c	(116.52)
7/25/2022	24398		Cintas - 56036	7/22/2022 Custodial	c	(116.52)
8/10/2022	24419		Cintas - 56036	8/5/2022 Custodial	c	(116.52)
8/23/2022	24434		Cintas - 56036	8/19/2022 Custodial	c	(116.52)
9/7/2022	24445		Cintas - 56036	8/31/2022 Custodial	c	(116.52)
9/21/2022	24469		Cintas - 56036	9/14/2022 Custodial	c	(116.52)
9/26/2022	24478	S	Smart & Final - 22935	Custodial cleaners, bleach, Pine Sol, Dawn	c	(33.16)
10/4/2022	24482		Cintas - 56036	9/28/2022 Custodial	c	(116.52)
10/13/2022	24498		Cintas - 56036	10/12/2022 Custodial	c	(116.52)
11/3/2022	24521		Cintas - 56036	10/26/2022 Custodial	c	(116.52)
11/3/2022	24523	S	Home Depot - 2843	Custodial items	c	(24.05)
11/14/2022	24534		Cintas - 56036	11/9/2022 Custodial	c	(116.52)
12/2/2022	24556		Cintas - 56036	11/23/2022 Custodial	c	(116.52)
12/8/2022	24575		Cintas - 56036	12/7/2022 Custodial	c	(116.52)
12/15/2022	24590	S	Smart & Final - 22935	Skunk Deodorizer Items	c	(6.18)
12/27/2022	24597		Cintas - 56036	12/21/2022 Custodial	c	(116.52)
1/4/2023	24618	S	Umpqua CC - 71085	8/Angel Brooms	c	(79.58)
1/10/2023	24619		Cintas - 56036	1/5/2023 Custodial	c	(116.52)
1/10/2023	24623	S	Home Depot - 2843	Clorox	c	(10.78)
2/6/2023	24646		Cintas - 56036	1/18/2023 Custodial	c	(298.62)
2/6/2023	24647		Cintas - 56036	2/1/2023 Custodial	c	(116.53)
2/15/2023	24658		Cintas - 56036	30 cases Trash Can Liners	c	(1,576.58)
2/21/2023	24674		Cintas - 56036	2/15/2023 - Custodial	c	(116.52)
3/6/2023	24686		Cintas - 56036	3/1/2023 Custodial	c	(116.52)
3/6/2023	24695	S	Umpqua CC - 71085	Kleenex - office use	c	(5.70)
3/15/2023	24697		Cintas - 56036	3/15/2023 Custodial	c	(116.52)



4/4/2023	24714 Cintas - 56036	3/29/2023 Custodial	c	(116.52)
4/12/2023	24730 S Home Depot - 2843	2 gal Sprayer	c	(50.61)
4/20/2023	24737 Cintas - 56036	4/12/2023 - Custodial	c	(116.52)
			<b>TOTAL 232200 Custodial Supplies</b>	<b>(4,415.67)</b>
<b>244300 Medical Service -EE &amp; Live Scan</b>				
10/20/2022	24509 Carmichael Box Shop - 59986	Live Scan - Bell	c	(25.00)
11/21/2022	24546 Carmichael Box Shop - 59986	Live Scan - Connolly	c	(25.00)
11/21/2022	24549 Preferred Alliance - 34429	Non-Random Test - Pre-placement - Bell, Connolly	c	(86.00)
1/17/2023	24629 State Of CA-Dept Of Justice - 8186	DOJ- Bell	c	(32.00)
			<b>TOTAL 244300 Medical Service -EE &amp; Live Scan</b>	<b>(168.00)</b>
<b>244400 Medical Supplies (First Aid)</b>				
11/3/2022	24532 S Umpqua CC - 71085	Replenish first aid supplies	c	(134.03)
12/2/2022	24572 S Umpqua CC - 71085	Replenish first aid supplies	c	(7.14)
			<b>TOTAL 244400 Medical Supplies (First Aid)</b>	<b>(141.17)</b>
<b>250700 Assessment - Collection Services</b>				
8/15/2022	24428 LAFCo - 2263	FY2022-23 - Special District Assessment	c	(109.00)
1/24/2023	EFT Assessment/Collection Service	SB 2557 1st Installment	c	(3,525.41)
2/22/2023	EFT # 110842872	SB2557 1st Installment	c	(34.05)
4/24/2023	EFT Assessment/Collection Service	SB 2557 2nd Installment	c	(3,559.46)
			<b>TOTAL 250700 Assessment - Collection Services</b>	<b>(7,227.92)</b>
<b>253100 Legal Services</b>				
7/12/2022	24381 Cole Huber - 54641	6/2022 Ref:ACP Property	c	(157.50)
9/13/2022	24460 Cole Huber - 54641	8/2022 Ref:ACP Property	c	(225.00)
10/13/2022	24500 Cole Huber - 54641	9/2022 Ref:Prep & Attend Brd Mtg/ACP Property	c	(450.00)
11/14/2022	24535 Cole Huber - 54641	10/2022 Ref:ACP Property/Respond Audit letter	c	(488.07)
12/15/2022	24581 Cole Huber - 54641	11/2022 Ref:ACP Property	c	(517.50)
1/10/2023	24620 Cole Huber - 54641	12/2022 Ref:ACP Prop. SASD & TRUSD, GM Contract	c	(1,260.00)
3/15/2023	24698 Cole Huber - 54641	2/2023 Ref:ACP Prop	c	(135.00)
4/12/2023	24726 Cole Huber - 54641	1/2023 Ref:TRUSD Prop, Prepare & attend Brd mtg	c	(292.50)
			<b>TOTAL 253100 Legal Services</b>	<b>(3,525.57)</b>
<b>257100 Security Services</b>				
7/26/2022	24402 Fulton-El Camino Rec & Park - 2968	6/2022 - Patrol Service 11/24 Hours	c	(2,275.00)
8/23/2022	24435 Fulton-El Camino Rec & Park - 2968	7/2022 - Patrol Service 31/16 Hours	c	(3,149.00)
9/7/2022	24458 S Umpqua CC - 71085	Trial Cams & Flkashdrive (security Items)	c	(233.78)

10/20/2022	24510	Fulton-El Camino Rec & Park - 2968	8/2022 - Patrol Service 18/-0- Hours Final Billing	c	(1,206.00)
			<b>TOTAL 257100 Security Services</b>		<b>(6,863.78)</b>
258200 Public Relations Services					
7/5/2022	24373	S Streamline - 57252	Streamline Website 1 yr	c	(1,200.00)
			Credit	c	100.00
			<b>TOTAL 258200 Public Relations Services</b>		<b>(1,100.00)</b>
259100 Other Professional Services					
8/2/2022	24408	Crime Alert Security - 41852	Alarm System deposit - Alarm Rental Facilities, Cameras	c	(6,740.00)
9/13/2022	24463	Crime Alert Security - 41852	Alarm System Install - Rental Facilities, Cameras	c	(6,740.00)
11/3/2022	24530	SCI Consulting Group - 2365	FY 18-19 Annual & 5 yr Nexus study (related consulting service)	c	(1,501.50)
11/14/2022	JV	# 110767206	Re-allocate Claim 24530 from 339A to 339I (Nexus Study)	c	1,501.50
12/27/2022	24600	Crime Alert Security - 41852	Upgrade Shop to LE4000E Universal Communicator	c	(260.00)
2/15/2023	24659	College Oak Towing - 617236	Tow abandoned vehicle @ ACP	c	(350.00)
			<b>TOTAL 259100 Other Professional Services</b>		<b>(14,090.00)</b>
281100 Data Processing -Computer Service					
2/21/2023	24675	Fast Break - 37998	3/BitDefender - Computer Security	c	(108.00)
			<b>TOTAL 281100 Data Processing -Computer Service</b>		<b>(108.00)</b>
281265 Application Software Maint. Lic					
8/2/2022	24409	Fast Break - 37998	1 Yr Renewal - Microsoft Office 365	c	(99.99)
9/7/2022	24444	S Central Control System - 23278	7/2022 Wireless Irrigation	c	(220.00)
			8/2022 Wireless Irrigation	c	(220.00)
			9/2022 Wireless Irrigation	c	(220.00)
11/3/2022	24520	Central Control System - 23278	11/2022 - Wireless irrigation	c	(220.00)
11/14/2022	24533	Central Control System - 23278	10/2022 - Wireless irrigation (rec'd inv 11/14/2022)	c	(220.00)
12/2/2022	24555	Central Control System - 23278	12/2022 - Wireless irrigation	c	(220.00)
1/4/2023	24607	Central Control System - 23278	1/2023 - Wireless irrigation	c	(220.00)
1/17/2023	24630	Fast Break - 37998	Renewal - 3 Domain Names	c	(75.00)
2/6/2023	24645	Central Control System - 23278	2/2023 - Wireless irrigation	c	(220.00)
3/6/2023	24685	Central Control System - 23278	3/2023 - Wireless irrigation	c	(220.00)
4/4/2023	24713	Central Control System - 23278	4/2023 - Wireless irrigation	c	(220.00)
			<b>TOTAL 281265 Application Software Maint. Lic</b>		<b>(2,374.99)</b>
281700 Election Services					
12/27/2022	24598	County Of Sacramento - Voter Registration - 14	2022 Election Cost	c	(1,887.00)
			<b>TOTAL 281700 Election Services</b>		<b>(1,887.00)</b>

283102 Mileage

7/20/2022	24394 Kim Cook - 919996	7/2022 - Mileage Reimb	c	(22.15)
8/15/2022	24427 Kim Cook - 919996	8/2022 - Mileage Reimb	c	(14.54)
9/7/2022	24449 Kim Cook - 919996	8/2022 - Mileage Reimb	c	(12.29)
9/7/2022	24450 Lisa Gonzalez - 932917	8/2022 - Mileage Reimb	c	(18.84)
10/4/2022	24485 Kim Cook - 919996	9/2022 - Mileage Reimb	c	(12.79)
10/4/2022	24486 Lisa Gonzalez - 932917	9/2022 - Mileage Reimb	c	(16.15)
10/24/2022	24516 Kim Cook - 919996	10/2022 - Mileage Reimb	c	(12.79)
11/14/2022	24540 Lisa Gonzalez - 932917	11/14/2022 - Mileage	c	(8.75)
12/2/2022	24562 Kim Cook - 919996	Adjusted mileage rate on prior reimbursements	c	(4.96)
12/2/2022	24563 Kim Cook - 919996	11/2022 Mileage reimb	c	(13.88)
12/2/2022	24564 Lisa Gonzalez - 932917	Adjusted mileage rate on prior reimbursements	c	(2.39)
1/4/2023	24609 Kim Cook - 919996	12/2022 - Mileage Reimb	c	(13.88)
2/6/2023	24650 Kim Cook - 919996	1/2023 - Mileage Reimb	c	(14.51)
2/6/2023	24651 Lisa Gonzalez - 932917	1/2023 - Mileage Reimb	c	(7.60)
2/21/2023	24676 Kim Cook - 919996	2/2023 - Mileage Reimb	c	(14.51)
2/21/2023	24677 Lisa Gonzalez - 932917	2/2023 - Mileage Reimb	c	(12.71)
3/15/2023	24701 Kim Cook - 919996	3/2023 - Mileage Reimb	c	(14.51)
4/25/2023	24742 Kim Cook - 919996	4/2023 - Mileage Reimb	c	(28.26)
			<b>TOTAL 283102 Mileage</b>	<b>(245.51)</b>

285200 Recreation Supplies

10/4/2022	24484 Home Depot - 2843	9/30/2022- Magic Show items	c	(10.75)
10/4/2022	24487 Lisa Gonzalez - 932917	Reimb- 9/30/2022 Magic Show items	c	(40.09)
10/20/2022	24512 Park Planet - 29271	HSP Replacement Inclusive Swing Seat	c	(1,679.25)
11/3/2022	24532 S Umpqua CC - 71085	Supplies for Magic Show on 9/30/2022	c	(14.81)
1/4/2023	24603 BSN Sports - 21480	2/Basketball Hoops	c	(376.67)
1/4/2023	24604 BSN Sports - 21480	8/Basketball Replacement Nets	c	(91.80)
			<b>TOTAL 285200 Recreation Supplies</b>	<b>(2,213.37)</b>

289800 Other Operating Exp - Supplies

8/10/2022	24424 S Umpqua CC - 71085	Official Document ref: ACP Property	c	(33.50)
8/15/2022	JV # 110691470	Re-allocate to 339D 420200 from 339A 289800 (Prop 68 Proje	c	33.50
9/7/2022	24458 S Umpqua CC - 71085	Prop 68 Sign, Notary for Documents	c	(212.83)
9/13/2022	JV # 110714399	Re-allocate to 339D 420200 from 339A 289800 (Prop 68 Proje	c	212.83
10/4/2022	24497 Umpqua CC - 71085	9/2022 Stmt	c	(203.50)
10/20/2022	JV # 110746256	Re-allocate to 339D 420200 from 339A 289800 (Prop 68 Proje	c	203.50
11/21/2022	24548 S Pet Waste Eliminator - 69321	Pet waste bags	c	(233.87)

1/10/2023	24623	S	Home Depot - 2843	Tax Accrual S/H	c	(2.09)
				Pet waste container trahs bags	c	(32.29)
				<b>TOTAL 289800 Other Operating Exp - Supplies</b>		<b>(268.25)</b>
289900 Other Oper Exp Fire Extingusher						
11/21/2022	24547		Jorgenson Co - 48104	2022 Yrly Fire Exten. Inspection @ HSP	c	(183.87)
				<b>TOTAL 289900 Other Oper Exp Fire Extingusher</b>		<b>(183.87)</b>
291300 Auditor Controller Services						
12/15/2022	24586		Larry Bain, CPA - 26727	FY 21/22 - Audit	c	(6,500.00)
				<b>TOTAL 291300 Auditor Controller Services</b>		<b>(6,500.00)</b>
291500 Compass Costs						
8/9/2022	EFT	S	<b>Compass License Fee</b>	FY 22/23 -Compass VPN Connection	c	(372.00)
				FY 22/23 - Compass License Fee	c	(699.83)
				<b>TOTAL 291500 Compass Costs</b>		<b>(1,071.83)</b>
291700 Alarm Services						
7/5/2022	24363		Crime Alert Security - 41852	7/2022 -9/30/2022- Alarm System - Office & Shop	c	(210.00)
7/5/2022	24371		Sacramento Control Systems - 1112	7/2022 -9/30/2022 -AES Fire Monitoring	c	(241.63)
9/7/2022	24446	S	Crime Alert Security - 41852	7 Days New System Blding Alarm & Cameras	c	(51.33)
				9/1 - 11/30/2022 Alarm System - Bldings	c	(135.00)
				9/1 - 11/30/2022 - Alarm System Cameras	c	(525.00)
9/13/2022	24462		Crime Alert Security - 41852	10/2022 -12/31/2022- Alarm System - Office & Shop	c	(210.00)
10/4/2022	24490		Sacramento Control Systems - 1112	10/2022 -12/31/2022 -AES Fire Monitoring	c	(241.63)
11/14/2022	24537	S	Crime Alert Security - 41852	12/1 - 2/28/2022 - Alarm system Bldings	c	(135.00)
				12/1 - 2/28/2022 - Alarm System Cameras	c	(525.00)
12/15/2022	24583		Crime Alert Security - 41852	1/2023 - 3/31/2022 Alarm System Office & Shop	c	(210.00)
12/27/2022	24599		Crime Alert Security - 41852	A/o 1/2023 - 3/31/2022 Alarm System Shop	c	(30.00)
1/4/2023	24614		Sacramento Control Systems - 1112	1/2023 - 3/31/2023 - AES Fire Monitoring	c	(241.63)
2/6/2023	24648	S	Crime Alert Security - 41852	3/1 - 5/31/2023 - Alarm system Bldings	c	(135.00)
				3/1 - 5/31/2023 - Alarm System Cameras	c	(525.00)
3/6/2023	24687		Crime Alert Security - 41852	4/2023 - 6/30/2022 Alarm System Office & Shop	c	(240.00)
4/12/2023	24733		Sacramento Control Systems - 1112	4/2023 - 6/30/2023 - AES Fire Monitoring (new rate)	c	(246.13)
				<b>TOTAL 291700 Alarm Services</b>		<b>(3,902.35)</b>
298700 Telephone Services						
7/5/2022	24365		Fast Break - 37998	6/2022 Phone service	c	(195.00)
7/12/2022	24382		Comcast - 12322	7/2022-Billing-Phone/HSI (w/late fee)	c	(116.59)

8/10/2022	24420	Comcast - 12322	8/2022-Billing-Phone/HSI	c	(106.61)
8/10/2022	24421	Fast Break - 37998	7/2022 Phone service	c	(195.00)
9/13/2022	24461	Comcast - 12322	9/2022-Billing-Phone/HSI	c	(106.61)
9/13/2022	24464	Fast Break - 37998	8/2022 Phone service	c	(195.00)
10/4/2022	24483	Fast Break - 37998	9/2022 Phone service	c	(195.00)
10/13/2022	24501	Comcast - 12322	10/2022-Billing-Phone/HSI	c	(106.41)
11/3/2022	24522	Fast Break - 37998	10/2022 Phone service	c	(195.00)
11/14/2022	24536	Comcast - 12322	11/2022-Billing-Phone/HSI	c	(106.41)
12/2/2022	24558	Fast Break - 37998	11/2022 Phone service	c	(195.00)
12/15/2022	24582	Comcast - 12322	12/2022-Billing-Phone/HSI	c	(106.41)
1/4/2023	24608	Fast Break - 37998	12/2022 Phone service	c	(195.00)
1/10/2023	24621	Comcast - 12322	1/2023 - Billing-Phone/HSI (new rate)	c	(112.27)
2/6/2023	24649	Fast Break - 37998	1/2023 Phone service	c	(195.00)
2/15/2023	24660	Comcast - 12322	2/2023 - Billing-Phone/HSI	c	(113.55)
3/6/2023	24688	Fast Break - 37998	2/2023 Phone service	c	(195.00)
3/15/2023	24699	Comcast - 12322	3/2023 - Billing-Phone/HSI	c	(136.50)
4/4/2023	24715	Fast Break - 37998	3/2023 Phone service	c	(195.00)
4/12/2023	24727	Comcast - 12322	4/2023 - Billing-Phone/HSI	c	(145.02)
				<b>TOTAL 298700 Telephone Services</b>	<b>(3,106.38)</b>

#### 298701 Cell Phones

7/5/2022	24366	Fast Break - 37998	1 year - email exchange + Board Mbrs	c	(660.00)
8/2/2022	24417	S T-Mobile - 32685	7/2022 - District Cell Phone	c	(29.42)
			GM phone (purchase pmt)	c	(33.34)
9/7/2022	24457	S T-Mobile - 32685	8/2022 - District Cell Phone	c	(29.42)
			GM phone (purchase pmt)	c	(33.34)
10/4/2022	24496	S T-Mobile - 32685	9/2022 - District Cell Phone	c	(29.42)
			GM phone (purchase pmt)	c	(33.34)
11/3/2022	24531	S T-Mobile - 32685	10/2022 - District Cell Phone	c	(29.41)
			GM phone (purchase pmt)	c	(33.34)
12/2/2022	24571	S T-Mobile - 32685	11/2022 - District Cell Phone	c	(29.41)
			GM phone (purchase pmt)	c	(33.34)
1/4/2023	24617	S T-Mobile - 32685	12/2022 - District Cell Phone	c	(29.41)
			GM phone (purchase pmt)	c	(33.34)
2/6/2023	24656	S T-Mobile - 32685	1/2023 - District Cell Phone	c	(29.50)
			GM phone (purchase pmt)	c	(33.34)
3/6/2023	24694	S T-Mobile - 32685	2/2023 - District Cell Phone	c	(29.50)
			GM phone (purchase pmt)	c	(33.34)
4/4/2023	24725	S T-Mobile - 32685	3/2023 - District Cell Phone	c	(29.51)

				GM phone (purchase pmt)	c	(33.34)
				<b>TOTAL 298701 Cell Phones</b>		<b>(1,225.06)</b>
299909 Expenditure Reimb. (Ins Claims)						
7/5/2022	24372		Staples Construction - 52639	HSP Vandalism 3/2022 - Public RR	c	(4,791.28)
8/15/2022	24430		Staples Construction - 52639	HSP Vandalism 3/2022 - Public RR	c	(15,154.49)
4/12/2023	JV	S	# 110885414	Re-allocate from 210300 to 299909 C#24568	c	(2,700.00)
				Re-allocate from 210300 to 299909 C#24632	c	(2,000.00)
				Re-allocate from 210300 to 299909 C#24633	c	(1,800.00)
				Re-allocate from 210300 to 299909 C#24655	c	(600.00)
				RE-allocate from 210300 to 299909 C#24666	c	(6,850.00)
				<b>TOTAL 299909 Expenditure Reimb. (Ins Claims)</b>		<b>(33,895.77)</b>
321000 Interest Expense						
7/5/2022	24374	S	Umpqua Bank - 52152	7/2022 - Side Fund Interest	c	(648.50)
7/25/2022	24401	S	Umpqua Bank - 52152	8/2022 - Side Fund Interest	c	(639.57)
8/23/2022	24440	S	Umpqua Bank - 52152	9/2022 - Side Fund Interest	c	(630.63)
9/26/2022	24479	S	Umpqua Bank - 52152	10/2022 - Side Fund Interest	c	(621.69)
10/24/2022	24517	S	Umpqua Bank - 52152	11/2022 - Side Fund Interest	c	(612.76)
11/22/2022	24552	S	Umpqua Bank - 52152	12/2022 - Side Fund Interest	c	(603.81)
12/27/2022	24602	S	Umpqua Bank - 52152	1/2023 - Side Fund Interest	c	(594.88)
1/25/2023	24642	S	Umpqua Bank - 52152	2/2023 - Side Fund Interest	c	(585.95)
2/21/2023	24679	S	Umpqua Bank - 52152	3/2023 - Side Fund Interest	c	(577.00)
3/28/2023	24710	S	Umpqua Bank - 52152	4/2023 - Side Fund Interest	c	(567.71)
4/25/2023	24743	S	Umpqua Bank - 52152	5/2023 - Side Fund Interest	c	(558.42)
				<b>TOTAL 321000 Interest Expense</b>		<b>(6,640.92)</b>
323000 Lease Oblig Retirement Side Fund						
7/5/2022	24374	S	Umpqua Bank - 52152	7/2022 - Side Fund Principal	c	(2,500.00)
7/25/2022	24401	S	Umpqua Bank - 52152	8/2022 - Side Fund Principal	c	(2,500.00)
8/23/2022	24440	S	Umpqua Bank - 52152	9/2022 - Side Fund Principal	c	(2,500.00)
9/26/2022	24479	S	Umpqua Bank - 52152	10/2022 - Side Fund Principal	c	(2,500.00)
10/24/2022	24517	S	Umpqua Bank - 52152	11/2022 - Side Fund Principal	c	(2,500.00)
11/22/2022	24552	S	Umpqua Bank - 52152	12/2022 - Side Fund Principal	c	(2,500.00)
12/27/2022	24602	S	Umpqua Bank - 52152	1/2023 - Side Fund Principal	c	(2,500.00)
1/25/2023	24642	S	Umpqua Bank - 52152	2/2023 - Side Fund Principal	c	(2,500.00)
2/21/2023	24679	S	Umpqua Bank - 52152	3/2023 - Side Fund Principal	c	(2,600.00)
3/28/2023	24710	S	Umpqua Bank - 52152	4/2023 - Side Fund Principal	c	(2,600.00)
4/25/2023	24743	S	Umpqua Bank - 52152	5/2023 - Side Fund Principal	c	(2,600.00)

			<b>TOTAL 323000 Lease Oblig Retirement Side Fund</b>	(27,800.00)
345000 Taxes, Licenses & Assessments				
10/4/2022	24491 Sacramento County - Tax Collectors Office - 472{HSP - CSA1 Lights		c	(655.74)
10/4/2022	24492 Sacramento County - Tax Collectors Office - 472{ACP - CSA1 Lights		c	(47.90)
			<b>TOTAL 345000 Taxes, Licenses &amp; Assessments</b>	(703.64)
			<b>TOTAL EXPENSES</b>	(291,127.95)
			<b>OVERALL TOTAL</b>	(291,127.95)

**ACRPD 2022-2023  
339D Expenditures**

**April 2023  
Period 10 of 13**

**FYTD Completed = 77%**

	CODE	CAPITAL OUTLAY	2022-23 Budget	April	Expended To Date	Balance	Percent Expended
1	20227504	Miscellaneous	31,410.00		31,410.00	-	100%
2							
3							
4							
5	42420100	Buildings <b>New ADA Features @ HSP</b>			-	-	#DIV/0!
6	42420110	Leasehold Improv. <b>(Oakdale Park)</b>			-	-	#DIV/0!
7	42420200	Structures <b>ACP Park Improv. Proj</b>			-	-	#DIV/0!
8	"	ACP Restroom Building	175,044.00		146,628.00	28,416.00	84%
9	"	ACP Parking Lot Repaving			-	-	#DIV/0!
10	"	ACP Improvements (Prop 68)	147,427.00		19,020.39	128,406.61	13%
11	43430300	Equipment-SD Non-Recon - <b>New Play Equip</b>			-	-	#DIV/0!
12	45450300	Infr--SD-Non-Recon - <b>ACP Pedi Bridge Proj</b>			-	-	#DIV/0!
13	46460300	Other Intangible Asset-Spec Dist - <b>HSP Comm. Ctr Impro.</b>			-	-	#DIV/0!
14	46461300	Intangibles - ???			-	-	
15					-	-	-0-
16		<b>TOTALS:</b>	<b>353,881.00</b>	<b>\$ -</b>	<b>\$ 197,058.39</b>	<b>\$ 156,822.61</b>	<b>56%</b>

*Funds placed in 20227504 - Miscellenous were placed in this GL Line item for the sole purpose of returning to the 339I Impact Fees account*



**ACRPD 2022-2023**  
**339D Revenue**

**April 2023**  
**Period 10 of 13**

**FYTD Completed = 77%**

	<b>Account</b>	<b>2022-23 Budget</b>	<b>April</b>	<b>Received To Date</b>	<b>Unrealized</b>	<b>Percent Received</b>
1	<b>94941000</b> Interest Income		671.00	761.00	(761.00)	#DIV/0!
				-	-	#DIV/0!
2	<b>95952900</b> In Lieu Fees Transfer			-	-	#DIV/0!
				-	-	#DIV/0!
3	<b>95956300</b> State-Federal Grants(Jo Smith Pedi Bridge Proj)			-	-	#DIV/0!
4	" State-Federal Grants (Dist Proj/Per Capita Funds)	147,427.00		-	147,427.00	0%
5	"			-	-	#DIV/0!
6	"			-	-	#DIV/0!
				-	-	#DIV/0!
7	<b>95956900</b> Other Funds - Local (339I Funds)			-	-	#DIV/0!
8	" *Jo Smith Pedi Bridge Proj			-	-	#DIV/0!
9	" *ACP-Park Improvements	175,044.00		175,044.00	-	100%
10	" *HSP Community Ctr Improvements			-	-	#DIV/0!
11	" *HSP ADA Improvements			-	-	#DIV/0!
12				-	-	#DIV/0!
13	<b>95956910</b> State Match <b>UMPQUA Bank Line of Credit</b>			-	-	#DIV/0!
14	" *Jo Smith Pedi Bridge Proj			-	-	#DIV/0!
15				-	-	#DIV/0!
16				-	-	#DIV/0!
17				-	-	#DIV/0!
18	<b>5506614</b> Investment Earns			-	-	#DIV/0!
19	<b>Total Other Revenue</b>	<b>\$ 322,471.00</b>	<b>\$ 671.00</b>	<b>\$ 175,805.00</b>	<b>\$ 146,666.00</b>	<b>55%</b>
20	Beginning Fund Balance Available \$XXXXX			-	\$ -	0%
21	Fund Balance Decreased by				\$ -	
22	<b>TOTALS:</b>	<b>322,471.00</b>	<b>671.00</b>	<b>175,805.00</b>	<b>146,666.00</b>	

Note: Per Resolution 2022-22 via JV 110777002, Short term loan of \$147,427.55 provided to 339D GL 5250000 by 339A GL 1800000  
 Note: Per Resolution 2023-01 via JV 110891191, Repaid Portion of Short term loan of \$128,406.61 provided to 339D GL 5250000  
 by 339A GL 1800000

**Register Expense Report**  
**Period 10**  
 Account

**FY 2022 - 2023**  
**4/1/2023 Through 4/30/2023**  
**339D Project Account**

**Not  
Clrd**

Date	Num	Description	Account	Memo	Category	Clrd	Amount
4/1/2023	Interest		FY 22/23 3rd Qtr Interest		941000 Interest	c	671.00
					TOTAL 4/1/2023 - 4/30/2023		671.00
					BALANCE 4/30/2023		10,156.80
					TOTAL INFLOWS		671.00
					TOTAL OUTFLOWS		-
					NET TOTAL		671.00

Date Num

Description

Memo

Clr

Amount

INCOME

941000 Interest

1/1/2023	Interest		FY 22/23 2nd Qtr Interest	c	90.00
4/1/2023	Interest		FY 22/23 3rd Qtr Interest	c	671.00
			<b>TOTAL 941000 Interest</b>		761.00

956900 Other Funds - Local (GRANTS)

10/4/2022	JV	# 110738172	Transferred from 339I to 339D ACP Restroom Project	c	175,044.00
			<b>TOTAL 956900 Other Funds - Local (GRANTS)</b>		175,044.00

**TOTAL INCOME** 175,805.00

EXPENSES

420200 Structures (Projects @ ACP)

7/5/2022	211	Public Restroom Company - 429070	ACP RR Project (339I Funds)	c	(57,235.00)
8/2/2022	212	Staples Construction - 52639	ACP RR Project (Prop 68 Funding)	c	(18,570.56)
8/15/2022	JV	# 110691470	e-allocate from 339A 289800 to 339D 420200 (Prop 68 Projec	c	(33.50)
9/7/2022	213	Public Restroom Company - 429070	ACP RR Project (339I Funds)	c	(47,043.00)
9/13/2022	JV	# 110714399	e-allocate to 339D 420200 from 339A 289800 (Prop 68 Projec	c	(212.83)
9/26/2022	214	Public Restroom Company - 429070	ACP RR Project (339I Funds)	c	(42,350.00)
10/20/2022	JV	# 110746256	e-allocate to 339D 420200 from 339A 289800 (Prop 68 Projec	c	(203.50)
			<b>TOTAL 420200 Structures (Projects @ ACP)</b>		(165,648.39)

**TOTAL EXPENSES** (165,648.39)

**OVERALL TOTAL** 10,156.61

**Arcade Creek Recreation and Park District  
2022 - 2023 Monthly Revenue Reports**

**April 2023**

**Period 10**

**339B - Grant Trust**

<u>Beginning Balance</u>	<u>Debits</u>	<u>Credits</u>	<u>Ending Balance</u>
\$ -	\$ -	\$ -	\$ -

**088H - Park Dedication**

<u>Beginning Balance</u>	<u>Debits</u>	<u>Credits</u>	<u>Ending Balance</u>
\$ 6,616.66	\$ -	\$ 47.00	\$ 6,663.66

**339C - ADA Funds**

<u>Beginning Balance</u>	<u>Debits</u>	<u>Credits</u>	<u>Ending Balance</u>
\$ 1,383.59	\$ -	\$ 10.00	\$ 1,393.59

**339I - Park Impact Fee's**

<u>Beginning Balance</u>	<u>Debits</u>	<u>Credits</u>	<u>Ending Balance</u>
\$ 326,541.28	\$ -	\$ 2,511.00	\$ 329,052.28

- 10/4/2022 Transferred \$175,044.00 to 339D ACP Restroom Blding Project
- 11/14/2022 Transferred \$1,501.50 charge from 339A to cover cost of Admin Fee 5yr annual & FY 18-19 Annual
- 1/11/2023 Transferred/returned funds in the amount of \$31,410.00 back to 339I from 339D
- 3/6/2023 Transferred \$5,569.78 to cover Inv dated 3/1/23 FY2021-22 Admin cost

**Arcade Creek Recreation Park District  
Monthly Payroll Report**

<b>Start of Pay Period</b>	<b>April 1, 2023</b>	<b>April 16, 2023</b>
<b>End of Pay Period</b>	<b>April 15, 2023</b>	<b>April 30, 2023</b>
<b>Payroll Issued:</b>	<b>April 28, 2023</b>	<b>May 15, 2023</b>

<b>Administration Division</b>	6351.32	6351.32	12,702.64
<b>Board Members = 5</b>		200.00	200.00
<b>Parks Division</b>	2229.15	2480.36	4,709.51
PT Maint	0		-
<b>Recreation Division</b>			
Monitors, etc	299.25	252.00	551.25
Misc - Staff	0.00	0.00	-
Rec. Staff (Other)	0.00	0.00	-
<b>\$</b>	<b>8,879.72</b>	<b>\$ 9,283.68</b>	<b>\$ 18,163.40</b>
<b>Employer Paid Taxes</b> <i>(FICA, Medicare, SUI)</i>	<b>684.10</b>	<b>Unavailable</b>	

**Rental & Misc. Revenue Report**

**April**

**2023**

**94942900 - SOCIAL/EVENT BUILDING / GPA / SPORT FIELD RENTALS**

Rental Date	Renter	Location	Amount
Games - 4 games	Legends Soccer Club	HSP Soccer Field	240.00
Practice 20 days	Legends Soccer Club	HSP Soccer Field	200.00

*Total Rentals* \$ **440.00**

**A**

**94942900 - LONG TERM STUDIO/ FIELD SPACE RENTAL**

Rental Date(s)	Renter	Location	Amount
Apr-23	Albree Dog Training	HSP	240.00

*Totals* \$ **240.00**

**B**

**94942900 - CELL TOWER REVENUE**

Apr-23	Site ID 810224 HSP- 810224 = 2,260.42 and 810213 ACP-810213 = \$2,350.00	4,610.42
--------	---	----------

*Totals* \$ **4,610.42**

**C**

**97979000 - MISC. OTHER REVENUES**

*Totals* \$ **-**

**D**

\$ 440.00	<b>A</b>
\$ 240.00	<b>B</b>
\$ 4,610.42	<b>C</b>
\$ -	<b>D</b>
<b>\$ 5,290.42</b>	<b>Total</b>

**Arcade Creek Recreation and Park District**

**MEETING DATE: May 18, 2023**

**AGENDA ITEM: 5 g Consent Agenda  
Correspondence Period 11**

**No correspondence received.**

# Arcade Creek

Recreation and Park District

May 18, 2023

**Board of Directors**  
Travis Dworetzky  
Amanda Gualderama  
Michael Hanson  
Chris Juell  
Alex Vassar

Dear Board of Directors,

I am still working with Staples to get their permits approved. Staples hired a permit expeditor and a Civil engineer to move things faster.

I will have signed a proposal with Lee Hazeltine, goat shepherd for goat grazing for Arcade Creek Park and we will be doing it in collaboration with American River College between April 10th to June 15, 2023.

I had the KYA group come out to look at our old tennis courts at Hamilton Street Park. They will have turned in a bid, but it was very costly. I also contacted the lead I was given by Scott Miller for First Serve Productions. I met with the owner Dave Klembith but have not heard back from him with a bid yet.

I had a final meeting with SMUD and Brighton Energy for our Energy Solutions Proposal today. In my absence Katie Worth from SMUD will be at the Board meeting on the agenda with packets for all Board Members

We had major water leaks at Hamilton Street Park which are getting repaired and broken sprinklers replaced as well.

Goats are scheduled to start on Friday, May 12, 2023 on the Joe Smith trail.

Michael Hanson and I will be meeting with JT Turpin and Mark Hodge from Staples Construction on May 11<sup>th</sup> at 10am at the District Office.

*Lisa Gonzalez*

**Mailing Address**  
P.O. Box 418114  
Sacramento, CA 95841

**Telephone**  
(916) 482-8377

**Email**  
acrpd@acrpd.com

**Arcade Creek Park**  
5613 Omni Drive  
Sacramento, CA

**Hamilton Street Park**  
4855 Hamilton Street  
Sacramento, CA

**Oakdale Park**  
3708 Myrtle Avenue  
North Highlands, CA



Arcade Creek Recreation and Park District

<b>Meeting Date May 18, 2023</b>		<b>Item # 6 a</b>
		<b>Old Business</b>
<b>Subject: Discussion regarding lease with Oakdale gym and community center</b>		
<b>Initiated or requested by</b>	<b>Item Type</b>	<b>Report coordinated or prepared by</b>
<input checked="" type="checkbox"/> Board <input checked="" type="checkbox"/> Staff <input type="checkbox"/> Other	<input checked="" type="checkbox"/> Informational <input checked="" type="checkbox"/> Direction	<p><i>Lisa Gonzalez</i> and Kim Cook</p>
<p><b><i>Item originally appeared on the December 15, 2022, January 19, 2023, February 16, 2023, March 16, 2023 and 4/20/2023 agendas.</i></b></p> <p><b>Objective</b> To pursue a way to leave our current contract with Twin Oaks School District.</p> <p><b>Background</b> ACRPD entered a 30-year contract Lease Agreement between Rio Linda Union School District (currently known as Twin Rivers Unified School District) and Arcade Creek Recreation and Park District, the current lease term began in April 12,2004 and endures through April 11, 2034.</p> <p><b>Budget/Cost Information</b> Legal fees from Derek Cole who is spearheading this transaction.</p> <p><b>Proposed Action</b> Discussion on December 15<sup>th</sup> Board meeting and add this agenda item to January 19<sup>th</sup> board meeting with report from Derek Cole and more discussion.  Currently this is an ongoing discussion.</p>		
<b>Coordination and Review</b> This is a standard practice of the Board.		<b>Attachment(s)</b>

Arcade Creek Recreation and Park District

<b>Meeting Date May 18, 2023</b>		<b>Item # 6b</b>
		<b>Old Business</b>
<b>Subject: Project list prioritized for FY 2023-24</b>		
<b>Initiated or requested by</b> <input checked="" type="checkbox"/> Board <input checked="" type="checkbox"/> Staff <input type="checkbox"/> Other	<b>Item Type</b> <input checked="" type="checkbox"/> Informational <input checked="" type="checkbox"/> Direction <input type="checkbox"/> Action	<b>Report coordinated or prepared by</b>  <a href="#">Lisa Gonzalez</a>
<b>Coordination and Review</b> This is a standard practice of the Board.		<b>Attachment(s)</b> Prioritized Projects

## **Prioritize Projects**

- **#1 Renovate shop with 3 different proposals.  
(Add a wood fence around the shop property)**
- **Basketball court at ACP**
- **Pickle courts at HSP**
- **Independent playground equipment at HSP**
- **Dog Park at HSP**

Arcade Creek Recreation and Park District

<b>Meeting Date May 18, 2023</b>		<b>Item # 6c</b>
		<b>Old Business</b>
<b>Subject: SMUD Complete Energy Solutions Proposal</b>		
<b>Initiated or requested by</b> <input checked="" type="checkbox"/> Board <input type="checkbox"/> Staff <input checked="" type="checkbox"/> Other	<b>Item Type</b> <input checked="" type="checkbox"/> Informational <input checked="" type="checkbox"/> Direction <input checked="" type="checkbox"/> Action	<b>Report coordinated or prepared by</b>  Proposal Provided by SMUD Representative Katie Worth
<b>Coordination and Review</b> This is a standard practice of the Board.		<b>Attachment(s)</b> SMUD Complete Energy Solutions Proposal



# SMUD Complete Energy Solutions Proposal

**Arcade Creek Rec & Park**  
**April 13, 2023**

*Prepared for:*

Arcade Creek Rec & Park  
4855 Hamilton Street  
Sacramento, CA 95841

This program is brought to you by SMUD and delivered by TRC and Brighton Energy.





Lisa Gonzalez  
4855 Hamilton Street  
Sacramento, CA 95841

Hello Lisa Gonzalez,

Welcome to the Complete Energy Solutions (CES) program. We know how important it is to manage the energy costs for your business. By participating in this program, you can complete comprehensive energy retrofits and upgrades to ensure long-term energy and carbon reduction savings. Our goal is to help you offset some of the up-front costs, so you can improve your energy systems without adding financial stress.

As your energy advisor, I'm here to guide you through the entire process and will help you review the assessment proposal, navigate the installation process, confirm upgrades are completed and ensure you receive your incentive in a timely manner. If financing is needed, I can provide options through the National Energy Improvement Fund's (NEIF) online financing portal, which matches customer energy efficiency and gas-to-electric conversion projects with available financing options.

We're here for you. We will support you beyond project completion to make sure your business can take advantage of other SMUD solutions.

Sincerely,

Tanya Privalov

[tanya@brightonenergy.net](mailto:tanya@brightonenergy.net)

## Proposal Overview: Savings and Costs

---

This overview section outlines all the available measures for your business. The following sections will provide more detail on each measure category. After you have reviewed, please initial below next to each work order you approve.

### Your proposed energy efficiency measures

Project Scope	Electricity Saved (annual kWh)	Simple Payback (yrs)	Monthly Savings (\$)	Annual Savings (\$)	5 Year Savings (\$)
Lighting	41,093.49	4.27	\$467.44	\$5,609.26	\$28,046.31
<b>Total</b>	<b>41,093.49</b>		<b>\$467.44</b>	<b>\$5,609.26</b>	<b>\$28,046.31</b>

## Project impact

### Environmental benefits

By implementing the energy efficiency measures outlined in this proposal, your first year project impact will be:

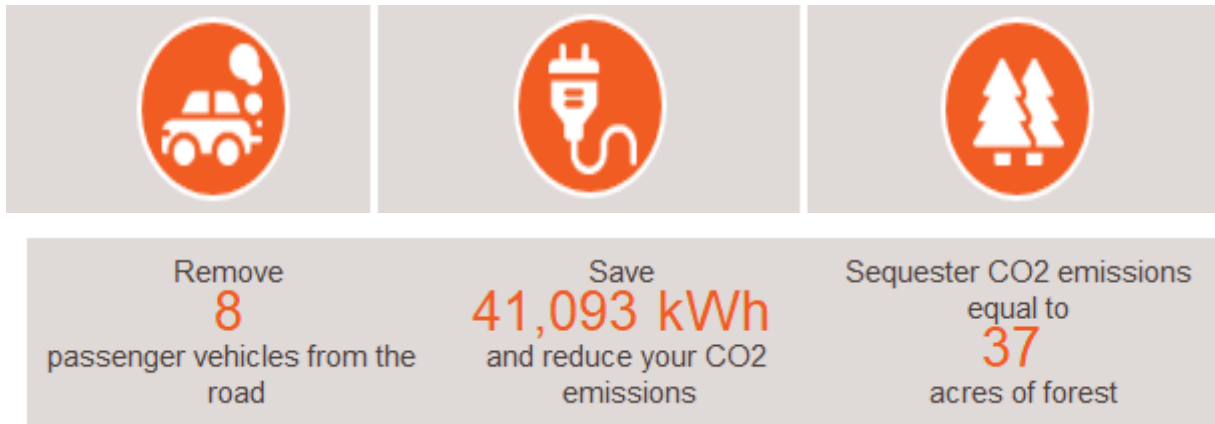

### Proposal Overview – Project Costs Summary

Project Scope	Material Cost (\$)	Labor Cost (\$)	SMUD Incentive (\$)	Customer Cost (\$)
Lighting	\$15,380.1	\$13,114	\$4,520.28	\$23,973.82
<b>Total</b>	<b>\$15,380.1</b>	<b>\$13,114</b>	<b>\$4,520.28</b>	<b>\$23,973.82</b>

Initial to approve work order(s):

Lighting



## Lighting Project scope

Location	AHO	Existing Equipment			Recommended Upgrade:			kWH Saved
		Existing Fixture Quantity	Existing Wattage	Existing Fixture Description	Proposed Fixture Quantity	Proposed Fixture Description	Proposed Wattage	
Exterior - Office	4368	4	61	CFL, 50W, twin, electronic ballast	4	20W WALL PACK 5000K - LEDONE	20	716.35
Exterior - Office (Courtel Lighting)	4368	3	464	High Pressure Sodium, (1) 400W lamp	3	20W WALL PACK 5000K - LEDONE	20	5,818.18
Interior Large Building	3380	35	74	Fluorescent, 48" (2) T12 lamps	35	23W 2x4 FLAT PANEL RETROFIT KIT MW MCCT - ESPEN	23	6,274.63
Interior - Lg Bldg Exit Signs	3380	3	29	Incandescent 40W equivalent (29W halogen)	3	EXIT LIGHT BAR - GREEN	3	274.18
Exterior -Lg Bldg	4368	9	66	CFL, 26W, quad, 2-lamp, mag ballast	9	20W WALL PACK 5000K - LEDONE	20	1,808.35
Exterior -Lg Bldg	4368	8	66	CFL, 26W, quad, 2-lamp, mag ballast	8	12W 8" CAN RETROFIT MW MCCT - LEDONE	10	1,956.86
Interior - Sm. Bldg Exit Signs	8736	4	29	Incandescent 40W equivalent (29W halogen)	4	EXIT LIGHT BAR - GREEN	3	944.88
Interior Sm Building	3380	19	114	Fluorescent, 48" (3) T12 lamps	19	23W 2x4 FLAT PANEL RETROFIT KIT MW MCCT - ESPEN	23	6,077.78
Pickleball Courts	936	20	1080	Metal halide, (1) 1000W	20	300W COMPACT	300	14,601.60

		Existing Equipment			Recommended Upgrade:			
Location	AHO	Existing Fixture Quantity	Existing Wattage	Existing Fixture Description	Proposed Fixture Quantity	Proposed Fixture Description	Proposed Wattage	kWH Saved
				lamp, mag ballast		AREA LIGHT 5000K 480V - Etherium		
Shop	3120	4	205	Fluorescent, 96" (2) T12 lamp, HO	4	46W 8FT STRIP RETROFIT FIXTURE - ALEO	48	2,096.52
Public RR Canopy	4368	2	75	Incandescent 75W	2	15W PAR38 5000K	15	524.16
Miscellaneous				Lift Fee	1			
Miscellaneous				Recycle Fee	1			

# Customer journey

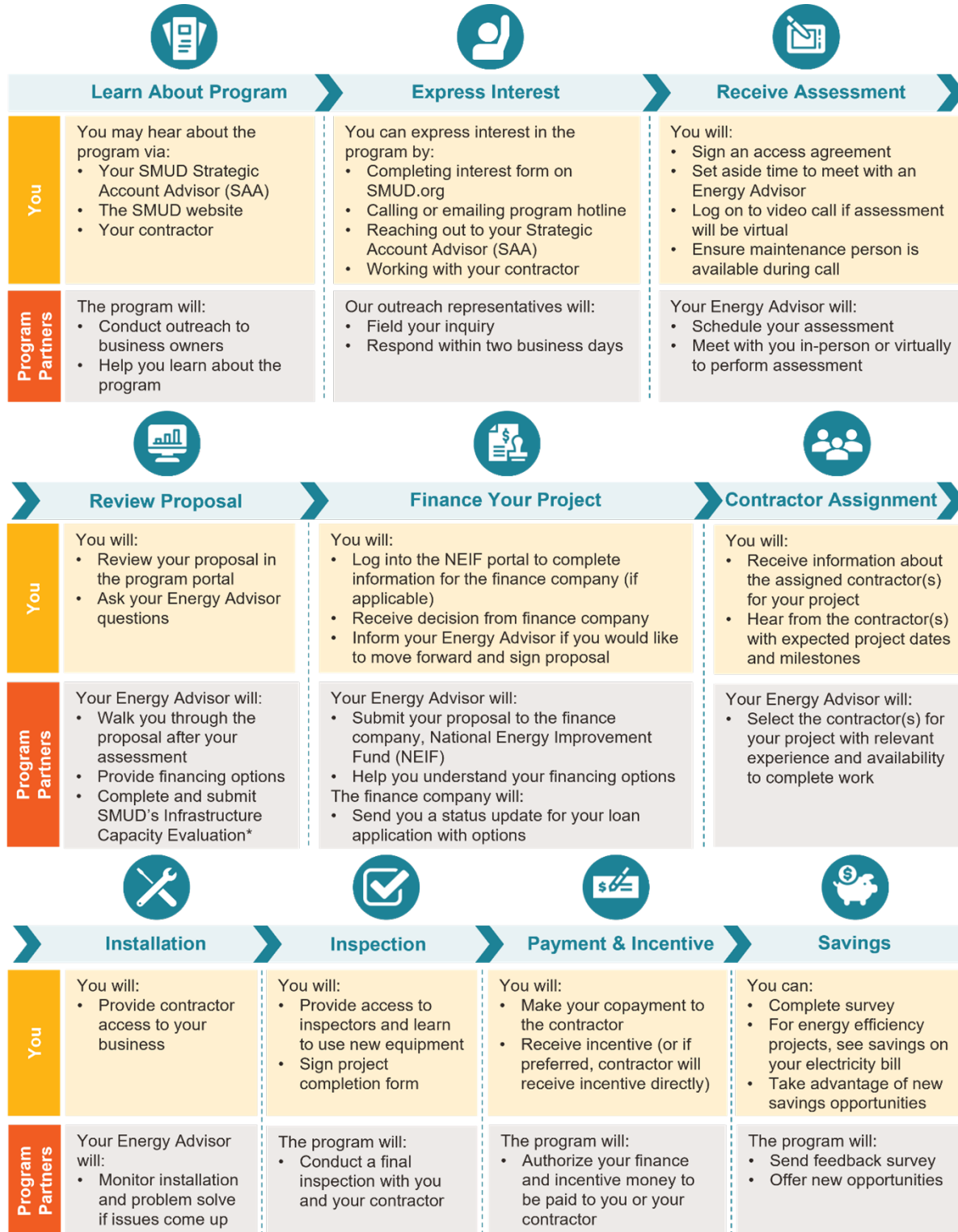

\*Mandatory submittal for all EV and Go Electric projects that could add load to a site

## Customer participation agreement

---

Lisa Gonzalez

4855 Hamilton Street

Sacramento, CA 95841

By signing this Customer Participation Agreement (“Agreement”), Customer (the business entity listed above) agrees to the following Terms and Conditions:

### **Measures and Incentives:**

I have reviewed the Energy Efficiency Upgrade Summary and Report (“Report”) provided by the Complete Energy Solutions Program (“Complete Energy Solutions”, “CES” or “Program”), a copy of which is attached to this Agreement. I agree that to the best of my knowledge the schedule of operations contained in the Report accurately describes the hours of operation at the facility listed above. I understand that the energy efficiency, electric vehicle, and Go-Electric measures described in the Report represent an estimate of expected energy savings and/or bill impacts, and that Complete Energy Solutions does not guarantee a specific level of cost savings from the implementation of the proposed energy efficiency measures (collectively, the “Project”). Complete Energy Solutions is administering the Project on the Customer’s behalf. Customer agrees to participate in SMUD’s Complete Energy Solutions Program provided in partnership with TRC Companies. Incentives for energy savings are calculated using the appropriate baseline to exceed California Title 20 and Title 24 standards. New products ordered, purchased, or installed prior to 4/1/20 or after 12/31/23 do not qualify for an incentive.

Resale products, products leased, rebuilt, rented, received from warranty of insurance claims, exchanged, won as a prize, or new parts installed in existing products do not qualify for incentives. SMUD is not responsible for the economic and technical feasibility, operational capability, and reliability of the Project.

### **Program Dates:**

To be eligible for incentives, all projects must be installed and completed before December 31, 2023. Funding of incentives is distributed on a first-come first-served basis.

### **Project Commitment and Installation Completion Process:**

I understand that I must have a signed Site Access Agreement on file to confirm Program eligibility, as well as this signed Customer Participation Agreement to initiate installation. For each work order, I agree to have Complete Energy Solutions contact (a) participating contractor(s) (“Contractor”) who will perform a walk-through inspection, review the scope of the Projects outlined in the Report, and schedule the Project installation at a time that is mutually agreeable to all parties. I understand that the total installed costs for the components of the Project are described in the attached listing of individual work orders. Costs for correcting electrical code violations are not included in the costs quoted above and are not covered by the Program. Any electrical code violations found during the Contractors’ inspections or during installation will be cause for the Contractor to stop work on the affected item(s) until such violations are corrected. I understand that the contractor walk-through may result in a Change Order due to specification or electrical code violations and that I will be notified and approve of any cost adjustments before additional work is completed.

Contractors are responsible for all on-site permitting and being properly equipped to conduct work on Program projects.



I will sign an agreement with each Contractor, which shall be solely between the Contractor and Customer, for the out-of-pocket portion of the Project costs. I understand that Complete Energy Solutions will provide an incentive, detailed in the work order listing, to offset the cost of the Project installations, and the incentive can be paid directly to the Contractors. I understand that I am responsible for paying the balance of the agreed-to contract price after incentive payment and that payment is due to the Contractor upon completion of the individual work order. By enrolling in the Program, I agree not to seek reimbursement from any other energy efficiency program for the same measures incentivized under other programs. I understand that I am responsible for reimbursing the Program should I receive other incentive payments for the same measures. At the completion of the Project, I agree to sign the Customer Acceptance/Project Completion Form presented by the Contractor on TRC Companies' behalf.

The value of incentives and direct installations is taxable, excluding energy efficiency related items. Program will report incentives and direct installations greater than \$600 to the IRS unless you are exempt. Please consult your tax advisor concerning the taxability of incentives. The Customer, not the Program, is responsible for any taxes imposed as a result of your receipt of incentives from this Program. Form 1099 will be issued for the Customer, regardless of who the payee is, because the Customer receives the benefits of the incentives.

For projects involving added load to a customer site, a SMUD Infrastructure Capacity Evaluation (ICE) must be submitted and returned to analyze the available existing transformer capacity. The CES team will help to fill out the form and submit it to SMUD. Additional load may require a Rule 16 application which requires a deposit, payable to SMUD, along with other associated infrastructure costs or fees. If a customer moves forward on a project in which the added load may exceed the existing infrastructure capacity, the CES team will work to identify all added costs or liabilities associated before the project commences.

I hereby authorize SMUD to share my business contact information with the Business Environmental Resource Center (BERC) of Sacramento County, for the purpose of qualifying my business for BERC programs, including BERC's Sacramento Area Sustainable Business program, following completion of project. This authorization will remain valid until revoked by me in writing. I may revoke this authorization at any time by providing written notice to SMUD. I hereby indemnify and forever hold SMUD harmless from any and all actions and causes of actions, suits, claims, attorney's fees, or demands against SMUD, which I or my heirs may have resulting from SMUD sharing my business contact information with BERC.

Customers receiving the SMUD Business Electricity Reports may see a change in the energy efficiency recommendations in future reports due to TRC Companies updating your business profile. Updating your business profile helps SMUD provide more relevant information in future reports.

## Customer approval

---

I have read and understood the Terms and Conditions of this Agreement. I certify that the information I have provided is true and correct.

IN WITNESS WHEREOF, the parties hereto have caused this Agreement to be executed by their duly authorized representatives as of the date set forth below.

I agree to assign my incentive to the Contractor. I understand that whether I assign the incentive to the Contractor or not, I remain the beneficiary of the incentive(s) and may receive a Form 1099 for which I am responsible.

Check this box if you do not agree to release the Project name, photos and other relevant Project information to SMUD Complete Energy Solutions, TRC (implementor), and their agents for use in reports, case studies and other materials for this Program.

The Electric Vehicle Service Equipment (EVSE) incentives are handled and processed through a collaboration with SMUD and/or through the CALeVIP Program. I will follow SMUD's Electric Vehicle or CALeVIP guidelines if pursuing incentives.

As shown in the proposed items cost section, customer Out of Pocket Cost is \$23,973.82.

Customer  
Customer Representative: Lisa Gonzalez  
Arcade Creek Rec & Park  
4855 Hamilton Street  
Sacramento, CA 95841  
Phone: (916) 297-2281  
Email: lgonzalez@acrpd.com

SMUD Complete Energy Solutions  
Energy Advisor: Tanya Privalov  
Brighton Energy  
2701 Cottage Way, Suite 11  
Sacramento, CA 95825  
Phone: (916) 545-4780  
Email: tanya@brightonenergy.net

---

Customer Representative's Title

---

Customer Representative's Printed Name

---

Customer Representative's Signature

---

Date

# ProGem™ LED Area Light

The ProGem™ LED Area Light, 170 lm/W, IP67 Wet Location, 0-10V Dimmable, Premium Outdoor Luminaire with AccuLum™ Smart Technology.

Illuminate from dusk to dawn with ProGem™ engineering and AccuLum™ Smart Control Technology. Remote program sensor functions to automate and control sensitivity and brightness levels for photocell, bi-level dimming, and motion detection.

FEATURES	
Lumen Output	17000 to 51000 lumens
Efficacy	170 lm/W
Input Voltage	120-277V or 277-480V
Dimmable	0-10V Continuous
CCT	4000K or 5000K
IP Rating	IP67 Wet Location
Impact Protection	IK10 /20J
Neutral Salt Spray /Fog Rating	Grade 9
Surge Protection	3kV-6.6kV: LN, 5kV-10kV: LN-PE/N-PE
Vibration Rating	3g
Warranty	10 Years

## APPLICATIONS

Premium outdoor luminaire suitable for parking areas, auto dealerships, industrial yards, building exteriors, roadways, alleys, and pedestrian walkways.

## CONSTRUCTION

Manufactured for weather-proof durability using solid heavy duty die cast aluminum housing with anti-UV polyester coating to resist water, salt, corrosion, discoloration, and scratching. IP67 Wet Location rated for dust-tight, temporary immersion: IEC 60529. Impact Protection IK10, 20 joules: IEC 62262:2002. NSS, Neutral Salt Spray Rating Grade 9, 0<A≤1%: ASTM B117-2018/ASTM D1654-05. Vibration Acceleration Rating 3g: IEC 6008-2-6:1995.

## ELECTRICAL

Input voltages 120-277V or 277-480V models with 0-10V Continuous Dimming. Operating temperatures -4°F to 122°F (-20°C to 50°C). Surge Protection Rating 3kV-6.6kV: L-N, 5kV-10kV: L-PE/N-PE: IEC 61000-4-5.

## MOUNTING

Adjustable options include Slip-Fit, Round /Square Pole, and Trunnion Mounts.

## OPTICS

Anti-UV Clear Polycarbonate IES /NEMA Type III Lens standard. Type II, Type IV, Type V Lens, and Glare Shield available.

## CONTROLS

PIR Photocell, Bi-Level Dimming, and Motion Detection programmable twist-lock cap with Remote Control. Shorting Cap for manual switch or timer control.

## LISTINGS

DLC Premium listed. UL certified to meet US and Canadian standards. FCC, CE and RoHS compliant.

## WARRANTY

10 year exclusive limited warranty. View complete product warranty information <https://etheriumled.com/warranty/>.

Project:
Date:
Catalog No:
Prepared By:

100W Models



150W, 200W Models



240W, 300W Models



Slip-Fit Mount



Trunnion Mount



Square /Round Pole Mount



Smart Sensor Cap



## CORRELATED COLOR TEMPERATURES (CCT)

4000K

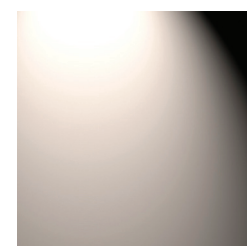

5000K

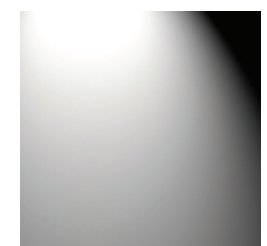

**SPECIFICATIONS**
**ENERGY DATA**
**Input Voltage:** 120-277V, 277-480V

**Input Frequency:** 50/60 Hz

**Wattage:** 100W, 150W, 200W, 240W, 300W

**Power Factor:** >0.9

**Total Harmonic Distortion (THD):** <15%

**Operating Temperature:** -4°F to 122°F (-20°C to 50°C)

**LIGHTING DATA**
**Lumens:** 17000 (100W), 25500 (150W), 34000 (200W), 40800 (240W), 51000 (300W)

**Lumens Per Watt:** 170 lm/W

**Color Correlated Temperature (CCT):** 4000K, 5000K

**Dimmable:** 0-10V

**Color Rendering Index (CRI):** >70

**L70:** 75000 hours

**ORDERING INFORMATION**

Model	Wattage	Voltage	Current	Lumens	Efficacy	CCT	Dimming	Color	Dimensions	Weight
ETH-A02-100W-HY-4000K	100W	120-277V	0.83A@120V, 0.36A@277V	17000	170 lm/W	4000K	0-10V	Dark Bronze	13.14"L x 12.40"W x 2.55"H	10.40 lbs
ETH-A02-100W-HY-5000K	100W	120-277V	0.83A@120V, 0.36A@277V	17000	170 lm/W	5000K	0-10V	Dark Bronze	13.14"L x 12.40"W x 2.55"H	10.40 lbs
ETH-A01-100W-HY-HV-4000K	100W	277-480V	0.36A@277V, 0.21A@480V	17000	170 lm/W	4000K	0-10V	Dark Bronze	13.14"L x 12.40"W x 2.55"H	10.40 lbs
ETH-A01-100W-HY-HV-5000K	100W	277-480V	0.36A@277V, 0.21A@480V	17000	170 lm/W	5000K	0-10V	Dark Bronze	13.14"L x 12.40"W x 2.55"H	10.40 lbs
ETH-A04-150W-HY-4000K	150W	120-277V	1.25A@120V, 0.54A@277V	25500	170 lm/W	4000K	0-10V	Dark Bronze	17.91"L x 12.40"W x 2.55"H	11.00 lbs
ETH-A04-150W-HY-5000K	150W	120-277V	1.25A@120V, 0.54A@277V	25500	170 lm/W	5000K	0-10V	Dark Bronze, White	17.91"L x 12.40"W x 2.55"H	11.00 lbs
ETH-A03-150W-HY-HV-4000K	150W	277-480V	0.54A@277V, 0.31A@480V	25500	170 lm/W	4000K	0-10V	Dark Bronze	17.91"L x 12.40"W x 2.55"H	11.00 lbs
ETH-A03-150W-HY-HV-5000K	150W	277-480V	0.54A@277V, 0.31A@480V	25500	170 lm/W	5000K	0-10V	Dark Bronze	17.91"L x 12.40"W x 2.55"H	11.00 lbs
ETH-A05-200W-HY-4000K	200W	120-277V	1.67A@120V, 0.72A@277V	34000	170 lm/W	4000K	0-10V	Dark Bronze	17.91"L x 12.40"W x 2.55"H	14.30 lbs
ETH-A05-200W-HY-5000K	200W	120-277V	1.67A@120V, 0.72A@277V	34000	170 lm/W	5000K	0-10V	Dark Bronze	17.91"L x 12.40"W x 2.55"H	14.30 lbs
ETH-A07-240W-HY-4000K	240W	120-277V	2.00A@120V, 0.87A@277V	40800	170 lm/W	4000K	0-10V	Dark Bronze	22.79"L x 12.40"W x 2.55"H	14.60 lbs
ETH-A07-240W-HY-5000K	240W	120-277V	2.00A@120V, 0.87A@277V	40800	170 lm/W	5000K	0-10V	Dark Bronze	22.79"L x 12.40"W x 2.55"H	14.60 lbs
ETH-A06-240W-HY-HV-4000K	240W	277-480V	0.87A@277V, 0.50A@480V	40800	170 lm/W	4000K	0-10V	Dark Bronze	22.79"L x 12.40"W x 2.55"H	14.60 lbs
ETH-A06-240W-HY-HV-5000K	240W	277-480V	0.87A@277V, 0.50A@480V	40800	170 lm/W	5000K	0-10V	Dark Bronze	22.79"L x 12.40"W x 2.55"H	14.60 lbs
ETH-A09-300W-HY-H-4000K	300W	120-277V	2.50A@120V, 1.08A@277V	51000	170 lm/W	4000K	0-10V	Dark Bronze	22.79"L x 12.40"W x 2.55"H	19.40 lbs
ETH-A09-300W-HY-H-5000K	300W	120-277V	2.50A@120V, 1.08A@277V	51000	170 lm/W	5000K	0-10V	Dark Bronze, White	22.79"L x 12.40"W x 2.55"H	19.40 lbs
ETH-A08-300W-HY-HV-4000K	300W	277-480V	1.08A@277V, 0.63A@480V	51000	170 lm/W	4000K	0-10V	Dark Bronze	22.79"L x 12.40"W x 2.55"H	19.40 lbs
ETH-A08-300W-HY-HV-5000K	300W	277-480V	1.08A@277V, 0.63A@480V	51000	170 lm/W	5000K	0-10V	Dark Bronze	22.79"L x 12.40"W x 2.55"H	19.40 lbs

Optics	Mount	Sensor	Accessory
T2 Type II Lens	A Slip-Fit (Adjustable)	ALPCSG2 Photocell Cap Sensor	AGLS Glare Shield
T3 Type III Lens	B Square or Round Pole (Adjustable)	ALMSPCSG2 Photocell + Dimming Motion Sensor	(Blank) None
T4 Type IV Lens	C Square Pole (Adjustable)	SC Shorting Cap	
T5 Type V Lens	D Trunnion Mount (Adjustable)		
	E None		

**ORDERING GUIDE**

ETH	A02	100W	HY	4000K	T3	A	ALPCSG2	AGLS
ETH	Group	Wattage	Voltage	CCT	Lens	Mount	Sensor	Accessory





**PHYSICAL DIMENSIONS**

**100W Models**

13.14"L x 12.40"W x 2.55"H

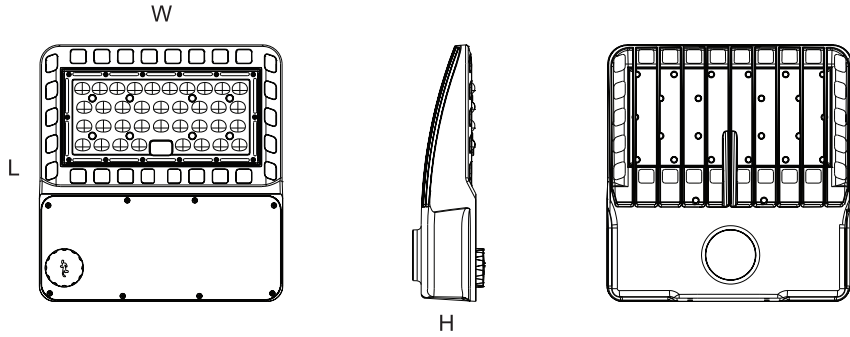

**150W and 200W Models**

17.91"L x 12.40"W x 2.55"H

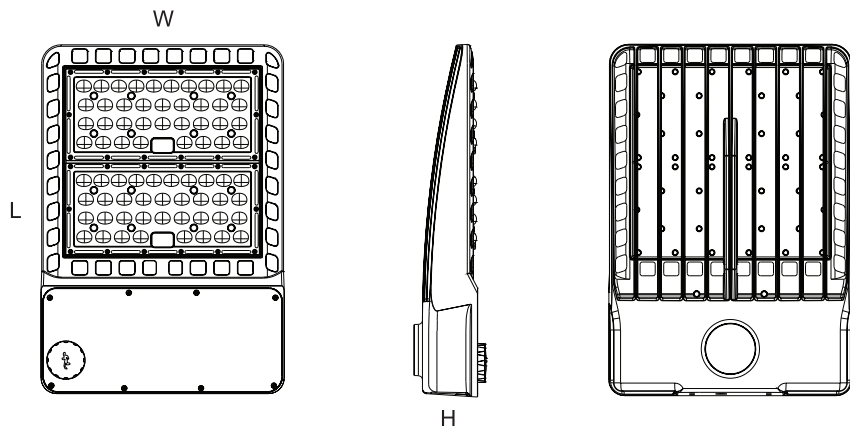

**240W and 300W Models**

22.79"L x 12.40"W x 2.55"H

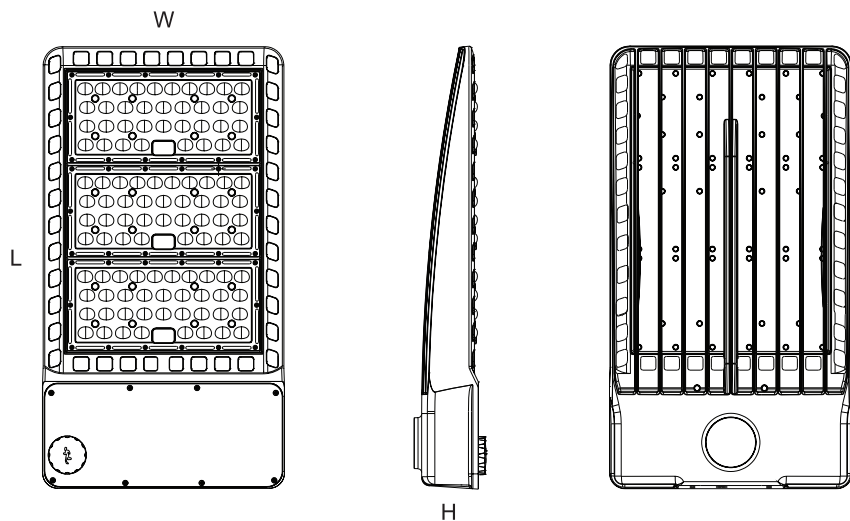

**Slip-Fit Mount**

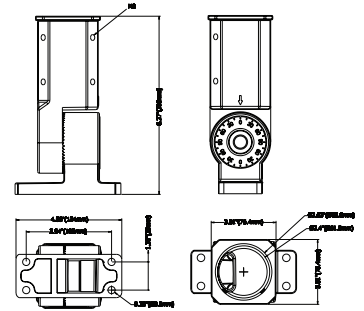

**Round /Square Pole Mount**

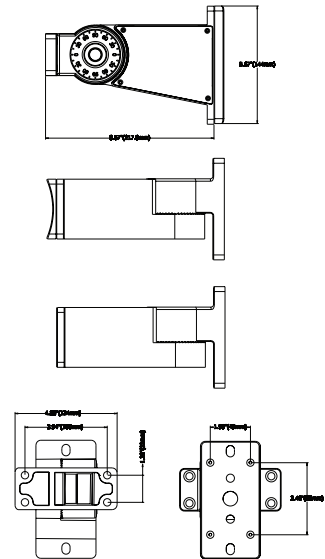

**Trunnion Mount**

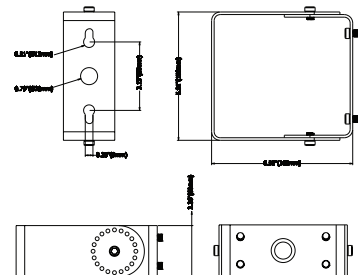

**SHIPPING INFORMATION**

Model Wattage	Mount Type	Unit Weight	Shipping Dimensions	Shipping Weight	Quantity /Box
100W	A - Slip Fit	11.2 lbs	24.6"L x 15.75"W x 5.3"D	13.2 lbs	1
	B - Square or Round Pole	12.3 lbs	24.6"L x 15.75"W x 5.3"D	14.3 lbs	1
	C - Square Pole	10.8 lbs	24.6"L x 15.75"W x 5.3"D	12.8 lbs	1
	D - Trunnion	11.2 lbs	24.6"L x 15.75"W x 5.3"D	13.2 lbs	1
	E - None	10.4 lbs	24.6"L x 15.75"W x 5.3"D	12.3 lbs	1
150W	A - Slip Fit	11.9 lbs	24.6"L x 15.75"W x 5.3"D	13.9 lbs	1
	B - Square or Round Pole	13.0 lbs	24.6"L x 15.75"W x 5.3"D	15.0 lbs	1
	C - Square Pole	11.5 lbs	24.6"L x 15.75"W x 5.3"D	13.4 lbs	1
	D - Trunnion	11.9 lbs	24.6"L x 15.75"W x 5.3"D	15.0 lbs	1
	E - None	11.0 lbs	24.6"L x 15.75"W x 5.3"D	13.0 lbs	1
200W	A - Slip Fit	15.2 lbs	27.1"L x 15.9"W x 5.3"D	17.4 lbs	1
	B - Square or Round Pole	16.3 lbs	27.1"L x 15.9"W x 5.3"D	18.5 lbs	1
	C - Square Pole	14.8 lbs	27.1"L x 15.9"W x 5.3"D	17.0 lbs	1
	D - Trunnion	15.2 lbs	27.1"L x 15.9"W x 5.3"D	17.4 lbs	1
	E - None	14.3 lbs	27.1"L x 15.9"W x 5.3"D	16.5 lbs	1
240W	A - Slip Fit	15.4 lbs	27.1"L x 15.9"W x 5.3"D	17.4 lbs	1
	B - Square or Round Pole	16.5 lbs	27.1"L x 15.9"W x 5.3"D	18.7 lbs	1
	C - Square Pole	15.0 lbs	27.1"L x 15.9"W x 5.3"D	17.2 lbs	1
	D - Trunnion	15.4 lbs	27.1"L x 15.9"W x 5.3"D	17.6 lbs	1
	E - None	14.6 lbs	27.1"L x 15.9"W x 5.3"D	16.8 lbs	1
300W	A - Slip Fit	20.3 lbs	32.0"L x 15.7"W x 5.3"D	22.9 lbs	1
	B - Square or Round Pole	21.2 lbs	32.0"L x 15.7"W x 5.3"D	24.0 lbs	1
	C - Square Pole	19.8 lbs	32.0"L x 15.7"W x 5.3"D	22.5 lbs	1
	D - Trunnion	20.3 lbs	32.0"L x 15.7"W x 5.3"D	22.9 lbs	1
	E - None	19.4 lbs	32.0"L x 15.7"W x 5.3"D	22.0 lbs	1

## ETH-A02-100W-HY-5000K (277V)

**Distribution:** Nema Type III, Short, Cutoff

**Lamp Output:** 17383.9 lumens

**Max Candela:** 5798.0 at Horizontal: 67.5°, Vertical: 61°

**Input Wattage:** 100.52

**Nema Type:** 7 X 7

**BUG:** B3 U3 G3

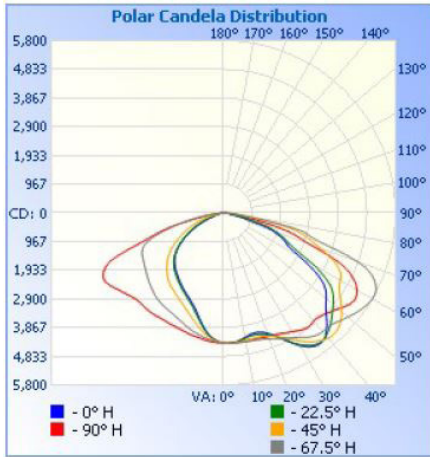

**Distribution:** Nema Type IV, Very Short, Semi-Cutoff

**Lamp Output:** 17358.8 lumens

**Max Candela:** 5616.1 at Horizontal: 337.5°, Vertical: 69°

**Input Wattage:** 101.07

**Nema Type:** 7 X 7

**BUG:** B3 U2 G2

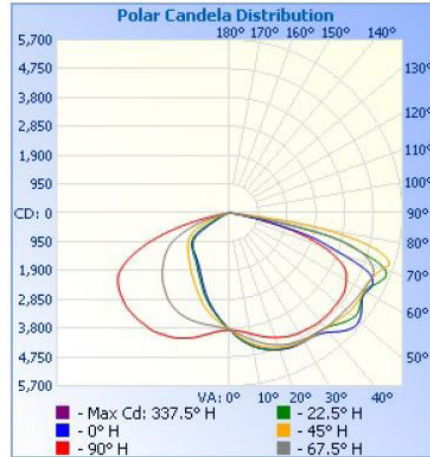

**Distribution:** Nema Type V, Very Short, Semi-Cutoff

**Lamp Output:** 17356.7 lumens

**Max Candela:** 4658.9 at Horizontal: 45°, Vertical: 70°

**Input Wattage:** 99.86

**Nema Type:** 7 X 7

**BUG:** B4 U2 G2

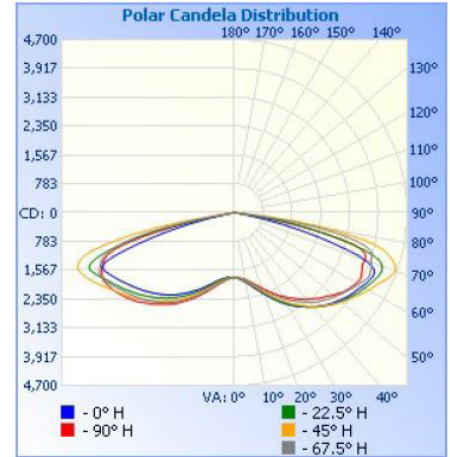

### ROADWAY SUMMARY

**Max Cd, 90° Vertical:** 18.4

**Max Cd, 80 to <90°:** 2780.7

	Lumens	% Lamp
Downward Street Side	10565.3	60.8%
Downward House Side	6648.8	38.2%
<b>Downward Total</b>	<b>17214.1</b>	<b>99%</b>
Upward Street Side	88.6	0.5%
Upward House Side	81.3	0.5%
<b>Upward Total</b>	<b>169.8</b>	<b>1%</b>
<b>Total Lumens:</b>	<b>17383.9</b>	<b>100%</b>

### FLOOD SUMMARY

	Efficacy	Lumens	Horiz. Spread	Vert. Spread
Field (10%)	97.4%	16929.9	159.2	152.5
Beam (50%)	77.9%	13548.1	139.9	112.7
<b>Total</b>	<b>99.9%</b>	<b>17375.6</b>		

### ILLUMINANCE

Height	Center Beam fc	Beam Width	Vert. Spread	Horiz. Spread
17.0 ft	15.2 fc	51.1 ft	93.2 ft	
34.0 ft	3.79 fc	102.1 ft	186.4 ft	
51.0 ft	1.68 fc	153.2 ft	279.6 ft	
68.0 ft	0.95 fc	204.2 ft	372.8 ft	
85.0 ft	0.61 fc	255.3 ft	466.0 ft	
102.0 ft	0.42 fc	306.3 ft	559.2 ft	
			<b>Vert. 112.7°</b>	<b>Horiz. 139.9°</b>

**Max Cd, 90° Vertical:** 18.9

**Max Cd, 80 to <90°:** 3287.3

	Lumens	% Lamp
Downward Street Side	12195.6	70.3%
Downward House Side	5115.9	29.5%
<b>Downward Total</b>	<b>17311.4</b>	<b>99.7%</b>
Upward Street Side	21.3	0.1%
Upward House Side	26.1	0.2%
<b>Upward Total</b>	<b>47.4</b>	<b>0.3%</b>
<b>Total Lumens:</b>	<b>17358.8</b>	<b>100%</b>

	Efficacy	Lumens	Horiz. Spread	Vert. Spread
Field (10%)	98.7%	17127.7	130.7	143.2
Beam (50%)	82.3%	14278.9	114.6	95.9
<b>Total</b>	<b>99.9%</b>	<b>17347.4</b>		

Height	Center Beam fc	Beam Width	Vert. Spread	Horiz. Spread
17.0 ft	13.3 fc	37.7 ft	53.0 ft	
34.0 ft	3.34 fc	75.4 ft	105.9 ft	
51.0 ft	1.48 fc	113.1 ft	158.9 ft	
68.0 ft	0.83 fc	150.8 ft	211.8 ft	
85.0 ft	0.53 fc	188.5 ft	264.8 ft	
102.0 ft	0.37 fc	226.2 ft	317.7 ft	
			<b>Vert. 95.9°</b>	<b>Horiz. 114.6°</b>

**Max Cd, 90° Vertical:** 19.4

**Max Cd, 80 to <90°:** 2780.7

	Lumens	% Lamp
Downward Street Side	8982.4	51.8%
Downward House Side	8318.2	47.9%
<b>Downward Total</b>	<b>17300.6</b>	<b>99.7%</b>
Upward Street Side	30.5	0.2%
Upward House Side	25.6	0.1%
<b>Upward Total</b>	<b>56.1</b>	<b>0.3%</b>
<b>Total Lumens:</b>	<b>17356.7</b>	<b>100%</b>

	Efficacy	Lumens	Horiz. Spread	Vert. Spread
Field (10%)	99.2%	17219.1	143.6	162.8
Beam (50%)	90.4%	15692.2	130.1	153.3
<b>Total</b>	<b>99.9%</b>	<b>17341.9</b>		

Height	Center Beam fc	Beam Width	Vert. Spread	Horiz. Spread
17.0 ft	6.10 fc	143.3 ft	73.1 ft	
34.0 ft	1.53 fc	286.7 ft	146.3 ft	
51.0 ft	0.68 fc	430.0 ft	219.4 ft	
68.0 ft	0.38 fc	573.3 ft	292.5 ft	
85.0 ft	0.24 fc	716.6 ft	365.6 ft	
102.0 ft	0.17 fc	860.0 ft	438.8 ft	
			<b>Vert. 153.3°</b>	<b>Horiz. 130.1°</b>

## ETH-A08-300W-HY-HV-5000K (480V)

**Distribution:** Nema Type III, Short, Cutoff

**Lamp Output:** 51798.7 lumens

**Max Candela:** 17100.6 at Horizontal: 67.5°, Vertical: 59°

**Input Wattage:** 297.54

**Nema Type:** 7 X 7

**BUG:** B5 U3 G4

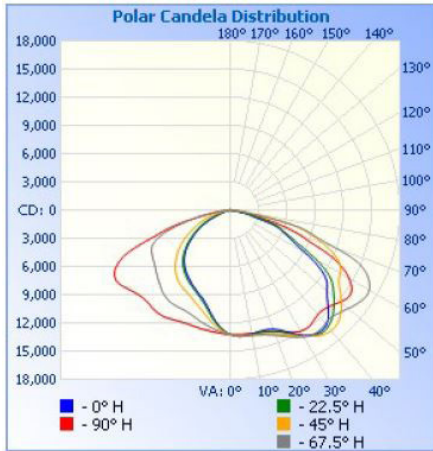

**Distribution:** Nema Type IV, Very Short, Non-Cutoff

**Lamp Output:** 51672.5 lumens

**Max Candela:** 16216.9 at Horizontal: 0°, Vertical: 49°

**Input Wattage:** 298.93

**Nema Type:** 7 X 7

**BUG:** B4 U3 G5

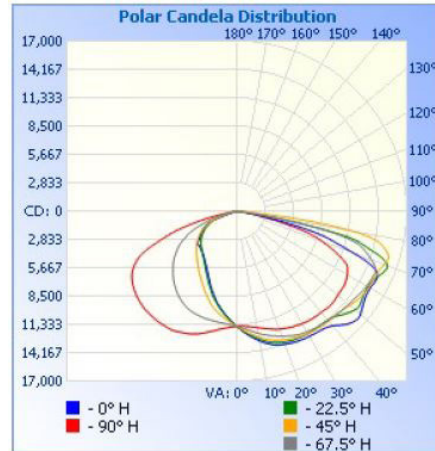

**Distribution:** Nema Type V, Very Short, Non-Cutoff

**Lamp Output:** 52051.2 lumens

**Max Candela:** 13831.3 at Horizontal: 225°, Vertical: 72°

**Input Wattage:** 296.95

**Nema Type:** 7 X 7

**BUG:** B5 U3 G5

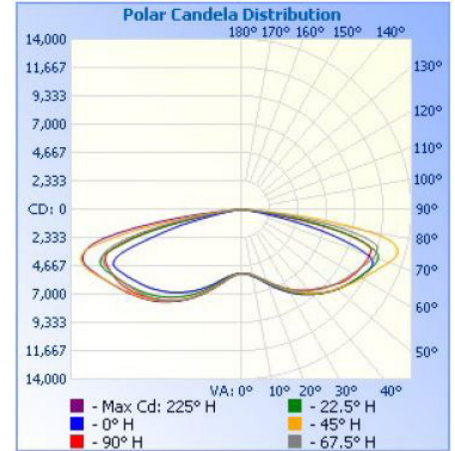

### ROADWAY SUMMARY

**Max Cd, 90° Vertical:** 503.4

**Max Cd, 80 to <90°:** 4345.8

	Lumens	% Lamp
Downward Street Side	31992.7	61.8%
Downward House Side	19557.9	37.8%
<b>Downward Total</b>	<b>51550.7</b>	<b>99.5%</b>
Upward Street Side	130.2	0.3%
Upward House Side	117.8	0.2%
<b>Upward Total</b>	<b>248.0</b>	<b>0.5%</b>
Total Lumens:	51798.7	100%

### FLOOD SUMMARY

	Efficacy	Lumens	Horiz. Spread	Vert. Spread
Field (10%)	97.9%	50720.6	158.5	148.7
Beam (50%)	80.0%	41454.7	138.9	108.4
<b>Total</b>	<b>100%</b>	<b>51776.3</b>		

### ILLUMINANCE

Height	Center Beam fc	Beam Width	
17.0 ft	45.7 fc	47.2 ft	90.7 ft
34.0 ft	11.4 fc	94.4 ft	181.3 ft
51.0 ft	5.08 fc	141.5 ft	272.0 ft
68.0 ft	2.86 fc	188.7 ft	362.6 ft
85.0 ft	1.83 fc	235.9 ft	453.3 ft
102.0 ft	1.27 fc	283.1 ft	544.0 ft
		Vert. 108.4°	Horiz. 138.9°

**Max Cd, 90° Vertical:** 59.2

**Max Cd, 80 to <90°:** 12153.0

	Lumens	% Lamp
Downward Street Side	35996.7	69.7%
Downward House Side	15516.9	30.0%
<b>Downward Total</b>	<b>51513.6</b>	<b>99.7%</b>
Upward Street Side	72.7	0.1%
Upward House Side	86.2	0.2%
<b>Upward Total</b>	<b>158.9</b>	<b>0.3%</b>
Total Lumens:	51672.5	100%

	Efficacy	Lumens	Horiz. Spread	Vert. Spread
Field (10%)	98.8%	51051.6	150.8	149.4
Beam (50%)	81.6%	42148.3	138.0	93.1
<b>Total</b>	<b>99.9%</b>	<b>51637.1</b>		

Height	Center Beam fc	Beam Width	
17.0 ft	39.9 fc	35.9 ft	88.5 ft
34.0 ft	9.97 fc	71.8 ft	177.1 ft
51.0 ft	4.43 fc	107.7 ft	265.6 ft
68.0 ft	2.49 fc	143.6 ft	354.2 ft
85.0 ft	1.60 fc	179.4 ft	442.7 ft
102.0 ft	1.11 fc	215.3 ft	531.3 ft
		Vert. 93.1°	Horiz. 138.0°

**Max Cd, 90° Vertical:** 75.4

**Max Cd, 80 to <90°:** 10691.6

	Lumens	% Lamp
Downward Street Side	26391.5	50.7%
Downward House Side	25472.1	48.9%
<b>Downward Total</b>	<b>51863.6</b>	<b>99.6%</b>
Upward Street Side	104.7	0.2%
Upward House Side	93.0	0.2%
<b>Upward Total</b>	<b>197.7</b>	<b>0.4%</b>
Total Lumens:	52051.2	100%

	Efficacy	Lumens	Horiz. Spread	Vert. Spread
Field (10%)	99.1%	51591.6	142.2	162.9
Beam (50%)	90.1%	46891.6	126.8	153.5
<b>Total</b>	<b>99.9%</b>	<b>52002.8</b>		

Height	Center Beam fc	Beam Width	
17.0 ft	18.3 fc	144.2 ft	68.0 ft
34.0 ft	4.58 fc	288.2 ft	135.9 ft
51.0 ft	2.03 fc	432.5 ft	203.9 ft
68.0 ft	1.14 fc	576.7 ft	271.9 ft
85.0 ft	0.73 fc	720.9 ft	339.8 ft
102.0 ft	0.51 fc	865.1 ft	407.8 ft
		Vert. 153.5°	Horiz. 126.8°

FLICKER RATING

**ETH-A02-100W-HY-XXXXK (277V)**

Frequency	MOD (no-effect)	MOD (low-risk)	100% dim	90% dim	75% dim	50% dim	20% dim	10% dim
40 Hz	0.4%	1.0%	0.05%	0.09%	0.14%	0.19%	0.23%	0.29%
90 Hz	3.0%	7.2%	0.08%	0.13%	0.18%	0.23%	0.28%	0.33%
200 Hz	6.7%	16.0%	0.12%	0.16%	0.20%	0.27%	0.32%	0.37%
400 Hz	13.3%	32.0%	0.17%	0.21%	0.26%	0.31%	0.39%	0.42%
1000 Hz	33.3%	80.0%	0.20%	0.25%	0.30%	0.37%	0.43%	0.51%

**ETH-A01-100W-HY-HV-XXXXK (480V)**

Frequency	MOD (no-effect)	MOD (low-risk)	100% dim	90% dim	75% dim	50% dim	20% dim	10% dim
40 Hz	0.4%	1.0%	0.07%	0.11%	0.15%	0.20%	0.24%	0.27%
90 Hz	3.0%	7.2%	0.10%	0.15%	0.17%	0.22%	0.27%	0.31%
200 Hz	6.7%	16.0%	0.14%	0.19%	0.23%	0.27%	0.33%	0.38%
400 Hz	13.3%	32.0%	0.19%	0.23%	0.26%	0.30%	0.37%	0.40%
1000 Hz	33.3%	80.0%	0.22%	0.24%	0.29%	0.35%	0.41%	0.49%

**ETH-A04-150W-HY-XXXXK (277V)**

Frequency	MOD (no-effect)	MOD (low-risk)	100% dim	90% dim	75% dim	50% dim	20% dim	10% dim
40 Hz	0.4%	1.0%	0.18%	0.22%	0.29%	0.34%	0.41%	0.57%
90 Hz	3.0%	7.2%	0.21%	0.28%	0.35%	0.46%	0.50%	0.61%
200 Hz	6.7%	16.0%	0.29%	0.35%	0.41%	0.55%	0.61%	0.69%
400 Hz	13.3%	32.0%	0.32%	0.43%	0.49%	0.59%	0.68%	0.76%
1000 Hz	33.3%	80.0%	0.41%	0.56%	0.63%	0.68%	0.76%	0.98%

**ETH-A03-150W-HY-HV-XXXXK (480V)**

Frequency	MOD (no-effect)	MOD (low-risk)	100% dim	90% dim	75% dim	50% dim	20% dim	10% dim
40 Hz	0.4%	1.0%	0.07%	0.13%	0.19%	0.24%	0.29%	0.34%
90 Hz	3.0%	7.2%	0.13%	0.17%	0.21%	0.28%	0.35%	0.41%
200 Hz	6.7%	16.0%	0.17%	0.22%	0.25%	0.31%	0.42%	0.48%
400 Hz	13.3%	32.0%	0.23%	0.26%	0.29%	0.40%	0.49%	0.55%
1000 Hz	33.3%	80.0%	0.28%	0.34%	0.37%	0.47%	0.53%	0.60%

**ETH-A05-200W-HY-XXXXK (277V)**

Frequency	MOD (no-effect)	MOD (low-risk)	100% dim	90% dim	75% dim	50% dim	20% dim	10% dim
40 Hz	0.4%	1.0%	0.21%	0.25%	0.32%	0.39%	0.47%	0.62%
90 Hz	3.0%	7.2%	0.26%	0.29%	0.38%	0.45%	0.53%	0.75%
200 Hz	6.7%	16.0%	0.32%	0.37%	0.43%	0.52%	0.66%	0.89%
400 Hz	13.3%	32.0%	0.39%	0.43%	0.51%	0.64%	0.72%	0.96%
1000 Hz	33.3%	80.0%	0.46%	0.52%	0.63%	0.71%	0.86%	1.52%

**ETH-A06-240W-HY-HV-XXXXK (480V)**

Frequency	MOD (no-effect)	MOD (low-risk)	100% dim	90% dim	75% dim	50% dim	20% dim	10% dim
40 Hz	0.4%	1.0%	0.11%	0.17%	0.25%	0.29%	0.39%	0.47%
90 Hz	3.0%	7.2%	0.16%	0.22%	0.33%	0.36%	0.46%	0.53%
200 Hz	6.7%	16.0%	0.23%	0.27%	0.38%	0.45%	0.55%	0.68%
400 Hz	13.3%	32.0%	0.29%	0.35%	0.44%	0.51%	0.62%	0.74%
1000 Hz	33.3%	80.0%	0.34%	0.41%	0.52%	0.63%	0.74%	1.24%

**ETH-A07-240W-HY-XXXXK (277V)**

Frequency	MOD (no-effect)	MOD (low-risk)	100% dim	90% dim	75% dim	50% dim	20% dim	10% dim
40 Hz	0.4%	1.0%	0.09%	0.12%	0.16%	0.19%	0.23%	0.28%
90 Hz	3.0%	7.2%	0.11%	0.15%	0.19%	0.24%	0.26%	0.31%
200 Hz	6.7%	16.0%	0.15%	0.18%	0.23%	0.27%	0.34%	0.42%
400 Hz	13.3%	32.0%	0.19%	0.22%	0.25%	0.30%	0.39%	0.57%
1000 Hz	33.3%	80.0%	0.24%	0.27%	0.32%	0.37%	0.43%	1.02%

**ETH-A08-300W-HY-HV-XXXXK (480V)**

Frequency	MOD (no-effect)	MOD (low-risk)	100% dim	90% dim	75% dim	50% dim	20% dim	10% dim
40 Hz	0.4%	1.0%	0.07%	0.09%	0.10%	0.13%	0.16%	0.21%
90 Hz	3.0%	7.2%	0.12%	0.15%	0.16%	0.17%	0.18%	0.26%
200 Hz	6.7%	16.0%	0.23%	0.24%	0.25%	0.30%	0.35%	0.47%
400 Hz	13.3%	32.0%	0.30%	0.33%	0.35%	0.42%	0.54%	0.61%
1000 Hz	33.3%	80.0%	0.54%	0.59%	0.61%	0.83%	1.02%	1.14%

**ETH-A09-300W-HY-XXXXK (277V)**

Frequency	MOD (no-effect)	MOD (low-risk)	100% dim	90% dim	75% dim	50% dim	20% dim	10% dim
40 Hz	0.4%	1.0%	0.14%	0.17%	0.21%	0.24%	0.28%	0.36%
90 Hz	3.0%	7.2%	0.19%	0.22%	0.25%	0.29%	0.33%	0.41%
200 Hz	6.7%	16.0%	0.27%	0.31%	0.38%	0.41%	0.45%	0.52%
400 Hz	13.3%	32.0%	0.36%	0.39%	0.42%	0.46%	0.51%	0.62%
1000 Hz	33.3%	80.0%	0.65%	0.70%	0.74%	0.77%	0.82%	1.22%

Reference Standard IEEE 1789: 2015

**SURGE PROTECTION**
**ETH-A02-100W-HY-XXXXK (277V)**

Test Items	Surge /kv	Interval time/S	Times	Process phenomenon	Criteria	Result
L-N	±3	60	5	Normal	B	Pass
L-N	±6.6	60	5	Normal	B	Pass
L-PE/N-PE	±5	60	5	Normal	B	Pass
L-PE/N-PE	±10	60	5	Normal	B	Pass

**ETH-A04-150W-HY-XXXXK (277V)**

Test Items	Surge /kv	Interval time/S	Times	Process phenomenon	Criteria	Result
L-N	±3	60	5	Normal	B	Pass
L-N	±6.6	60	5	Normal	B	Pass
L-PE/N-PE	±5	60	5	Normal	B	Pass
L-PE/N-PE	±10	60	5	Normal	B	Pass

**ETH-A05-200W-HY-XXXXK (277V)**

Test Items	Surge /kv	Interval time/S	Times	Process phenomenon	Criteria	Result
L-N	±3	60	5	Normal	B	Pass
L-N	±6.6	60	5	Normal	B	Pass
L-PE/N-PE	±5	60	5	Normal	B	Pass
L-PE/N-PE	±10	60	5	Normal	B	Pass

**ETH-A07-240W-HY-XXXXK (277V)**

Test Items	Surge /kv	Interval time/S	Times	Process phenomenon	Criteria	Result
L-N	±3	60	5	Normal	B	Pass
L-N	±6.6	60	5	Normal	B	Pass
L-PE/N-PE	±5	60	5	Normal	B	Pass
L-PE/N-PE	±10	60	5	Normal	B	Pass

**ETH-A09-300W-HY-XXXXK (277V)**

Test Items	Surge /kv	Interval time/S	Times	Process phenomenon	Criteria	Result
L-N	±3	60	5	Normal	B	Pass
L-N	±6.6	60	5	Normal	B	Pass
L-PE/N-PE	±5	60	5	Normal	B	Pass
L-PE/N-PE	±10	60	5	Normal	B	Pass

**ETH-A01-100W-HY-HV-XXXXK (480V)**

Test Items	Surge /kv	Interval time/S	Times	Process phenomenon	Criteria	Result
L-N	±3	60	5	Normal	B	Pass
L-N	±6.6	60	5	Normal	B	Pass
L-PE/N-PE	±6.6	60	5	Normal	B	Pass
L-PE/N-PE	±10	60	5	Normal	B	Pass

**ETH-A03-150W-HY-HV-XXXXK (480V)**

Test Items	Surge /kv	Interval time/S	Times	Process phenomenon	Criteria	Result
L-N	±3	60	5	Normal	B	Pass
L-N	±6.6	60	5	Normal	B	Pass
L-G	±6.6	60	5	Normal	B	Pass
L-G	±12	60	5	Normal	B	Pass
N-G	±6.6	60	5	Normal	B	Pass
N-G	±12	60	5	Normal	B	Pass

**ETH-A06-240W-HY-HV-XXXXK (480V)**

Test Items	Surge /kv	Interval time/S	Times	Process phenomenon	Criteria	Result
L-N	±3	60	5	Normal	B	Pass
L-N	±6.6	60	5	Normal	B	Pass
L-PE/N-PE	±5	60	5	Normal	B	Pass
L-PE/N-PE	±10	60	5	Normal	B	Pass

**ETH-A08-300W-HY-HV-XXXXK (480V)**

Test Items	Surge /kv	Interval time/S	Times	Process phenomenon	Criteria	Result
L-N	±3	60	5	Normal	B	Pass
L-N	±6.6	60	5	Normal	B	Pass
L-PE/N-PE	±5	60	5	Normal	B	Pass
L-PE/N-PE	±10	60	5	Normal	B	Pass

Reference Standard IEC 61000-4-5

- Testing Criteria B: Temporary loss of function or degradation of performance and recover its normal performance without operator intervention.

# LEDone®

Exterior Wallpacks - Office & Lg. Bldg.  
(to match existing lighting on Sm.  
Bldg. )

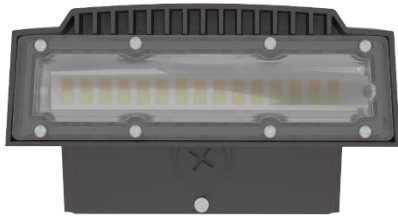

20W / 30W / 40W / 50W

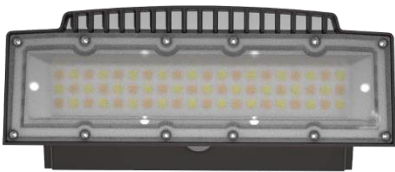

50W / 60W / 80W / 100W

WATTAGE	BUG RATING
50W	B3-U1-G1
100W	B3-U1-G1

## LED Multi Watt Multi CCT Adjustable Wall Pack Light Family Series

### CONSTRUCTION:

Heavy die-cast aluminum housing with polyester powder-coated finish. Integral secondary heat sink to optimize thermal transfer and maximize performance of the LEDs.

### OPTICAL SYSTEM:

Philips Lumiled 3030 LED chips. High quality tempered glass optics. 100° beam angle.

### WARRANTY:

5-year limited warranty. Actual performance may differ as a result of end-user environment and application.

### ELECTRICAL:

Available as 120-277V input. -40°C to 40°C, -40°F to 104°F

### INSTALLATION & MOUNTING:

Wall mount.

### CONTROLS & DIMMING:

0-10V dimming comes standard.

### FEATURES

- Default Wattage:
  - 50W
  - 100W
- Default CCT: 5,000K
- Photocell included
- IP65 rated
- Easy installation and maintenance
- Corrosion and rust proof
- 50,000 hours lifetime

### SUITABLE APPLICATIONS

- Residential Complexes
- Parking Decks
- Shopping Malls
- Sporting Complexes
- Logistic Centers
- Auto dealerships
- Municipal Lots

### DLC Product ID:

- LOC-AWP-MW(20/30/40/50)MCCT(30/40/50)D – S-YEV8RK
- LOC-AWP-MW(50/60/80/100)MCCT(30/40/50)D – S-G9FOKC

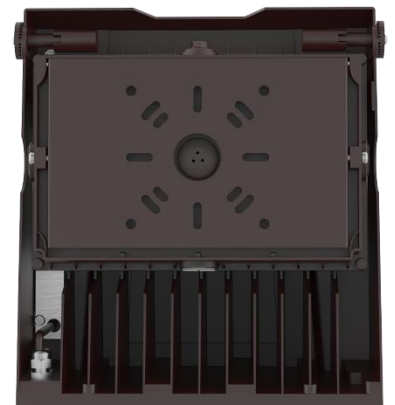

LOC-AWP-MW(20/30/40/50)MCCT(30/40/50)D

WATTAGE SELECTABLE	CCT SELECTABLE	LUMENS	EFFICACY	VOLTAGE	CRI	POWER FACTOR	THD	REPLACES
20W	3000K / 4000K / 5000K	2,400LM	120lm/W	120-277V	70	0.9	20%	100W
30W	3000K / 4000K / 5000K	3,600LM	120lm/W	120-277V	70	0.9	20%	100W
40W	3000K / 4000K / 5000K	4,800LM	120lm/W	120-277V	70	0.9	20%	100W
50W	3000K / 4000K / 5000K	6,000LM	120lm/W	120-277V	70	0.9	20%	100W

LOC-AWP-MW(50/60/80/100)MCCT(30/40/50)D

WATTAGE SELECTABLE	CCT SELECTABLE	LUMENS	EFFICACY	VOLTAGE	CRI	POWER FACTOR	THD	REPLACES
50W	3000K / 4000K / 5000K	6,500LM	130lm/W	120-277V	70	0.9	20%	100W
60W	3000K / 4000K / 5000K	7,800LM	130lm/W	120-277V	70	0.9	20%	150W
80W	3000K / 4000K / 5000K	10,400LM	130lm/W	120-277V	70	0.9	20%	200W
100W	3000K / 4000K / 5000K	13,000LM	130lm/W	120-277V	70	0.9	20%	200W

## MEASUREMENTS

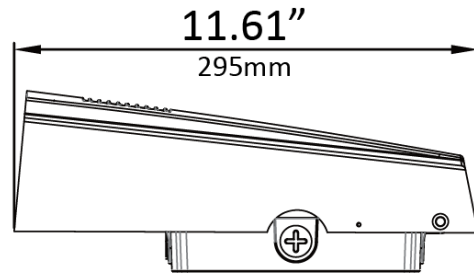
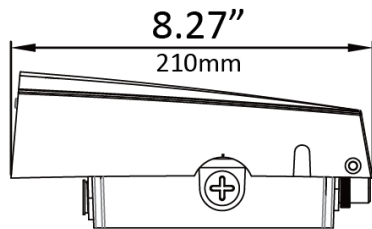
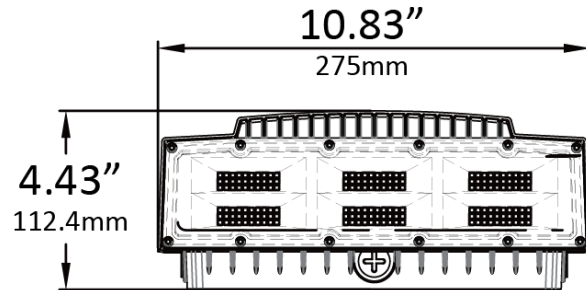
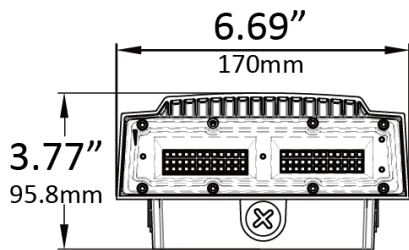

20W / 30W / 40W / 50W

50W / 60W / 80W / 100W

MODEL	QUANTITY	WEIGHT	UPC CODE
LOC-AWP-MW(20/30/40/50)MCCT(30/40/50)D	1	4.85 lbs	00810050942737
LOC-AWP-MW(50/60/80/100)MCCT(30/40/50)D	1	8.38 lbs	00810050942744



BAA/TAA Compliant LED Panel Retrofit Kit 2X4

**APPLICATIONS**

This advanced troffer retrofit kit easily converts 2X4 fluorescent troffers to the most current LED technology. Its ultra high efficiency reduces energy costs. It is one of the LED troffer retrofits that comes completely assembled as a lensed kit, requiring only one minute to install, reducing labor costs. The retrofit kit is also 0-10V Dimmable with 5 Year Warranty. Ideal applications include: office, retail, healthcare, education and hospitality interiors.

**PERFORMANCE**

The VEK series uses the latest LED technology and LED driver to ensure steady performance and long lifetime.

**INSTALLATION**

The Troffer Retrofit Kit provides the ideal way to replace existing 2X4 recessed troffer, utilizing the existing fixture housing. The kit provides all the components needed to perform the change out quickly and efficiently, allowing for system upgrades without disturbing the ceiling. The LED troffer retrofit is completely assembled within the frame. With special 2-in-1 design, the kit fits for both air return troffers and standard troffers.

[\\*Emergency Driver Solution Option](#)



**Specification Data**

Model No.	Watts (W)	Lumens (lm)	CCT	Efficacy (lm/W)	Input Voltage (Vac)	Dimming	Life (L70) hours	THD
VEKT-DP2X4 (23W/30W/36W) BAA	23/30/36	2875/3750/4500	3500/4000/5000	125 lm/W	120-277V	0-10V	>100,000	<20%

**Dimensions**

Length	Width	Height
3.79 ft	1.85 ft	2 in

**Ordering Information**

Sample model: VEKT-P2X2/840 BAA

VEKT-P	2X2	H	4000K	BAA
Series	Size	Lumen Package	CCT	COO
LED Panel Retrofit Kit	2'X2'	H = 22 Wattage	3500K 4000K 5000K	BAA TAA

**Wiring Diagram**

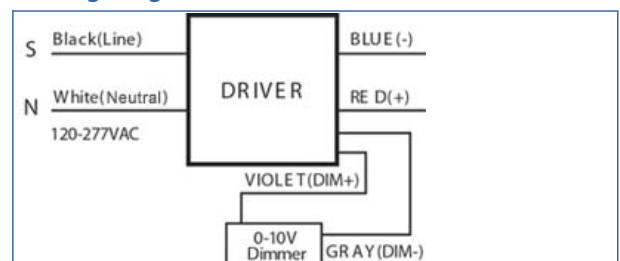

**DLC Information**

Order Code	DLC Product ID	DLC Product Model	DLC Version
VEKT-DP2X4 (23W/30W/36W) BAA	PL66CLS8VW0J	VEKT-DP2X4	5.1

<b>Meeting Date</b> <b>May 18, 2023</b>		<b>Item # 7 a</b> <b>New Business</b>
<b>Subject: Finance Committee report and proposal for the FY 2023-24 Preliminary Budgets for 339A General Budget and 339D District Projects</b>		
<b>Initiated or requested by</b> <input checked="" type="checkbox"/> Board <input type="checkbox"/> Staff <input type="checkbox"/> Other	<b>Item Type</b> <input checked="" type="checkbox"/> Informational <input checked="" type="checkbox"/> Direction <input type="checkbox"/> Action	<b>Report coordinated or prepared by</b>  <i>Kim Cook</i>
<p><b>Objective</b>          This is a standing agenda item for the Finance Committee to discuss with the full board the Committee's work and the development of the 2023-24 Budgets.</p> <p><b>Background</b>          Per the County Department of Finance, preliminaries budgets need to be adopted and submitted by the end of each June and the final budget presented in August and delivered to the County by September 1<sup>st</sup> of each year.</p> <p>A preliminary budget is only a place holder for the District to operate at the beginning of each new Fiscal Year.</p> <p>Preliminary budgets are presented at the May meetings for the Board to review and discuss.</p> <p>This is also the time for the Public to review.</p> <p>The final preliminary budgets will be placed on the June agenda for the Board to take action, so that it can be delivered to the County of Sacramento Department of Finance by the June 30<sup>th</sup>, 2023 deadline.</p> <p><b>Analysis</b>          One month remains until the Board must adopt the FY 2023-24 preliminary budget.</p> <p><b>Budget/Cost Information</b>          Major. This agenda item permits district residents and park users to comment on and make suggestions related to the proposed 2023-24 Budget.</p> <p><b>Proposed Action</b>          Discuss the Park District's Preliminary 2023-24 Budget.</p> <p><b>Alternative Actions</b>          This is a discussion item only.</p>		
<b>Coordination and Review</b> This is a standard practice of the Board.		<b>Attachment(s)</b> 339A General Fund Preliminary Budget 339D District Projects Preliminary Budget

For Review

FY 2023-24

**339A**

**General Fund**

Preliminary Budget

**For PRESENTATION @ 5/18/2023 Board Meeting**

**Expenses**

**EXPENDITURE DETAIL SCHEDULE - FY 2023-24 PRELIMINARY BUDGET**

**SPECIAL DISTRICT - ARCADE CREEK RECREATION AND PARK DISTRICT**

Fund Center	Commitment Item	Description	History Expense FY 20-21	History Expense FY 21-22	Actual Adopted 22-23	ACTUAL 22-23 As of 4/30/2023	Ending Projection For FY 22-23	Preliminary Budget FY 23-24
FUND	339 A Arcade Creek Recreation and Park District		Actual	Actual	Final	Expended	"Estimated"	Figures Rounded
9339339	10111000	SALARIES & WAGES - REGULAR EMPLOYEES	177,996.88	200,426.00	248,990.00	180,509.43	218,026.00	283,474.00
9339339	10112400	SALARIES & WAGES - COMMISSION & CO	3,650.00	2,400.00	3,500.00	2,150.00	2,850.00	3,500.00
9339339	10113200	OVER-TIME WAGES (if needed)	3,939.26	3,168.00	4,000.00	3,275.69	5,000.00	4,000.00
9339339	10115200	TERMINAL PAY	1,978.26	-				0.00
9339339	10121000	RETIREMENT - EMPLOYER COST	36,404.76	38,150.00	21,515.00	17,474.80	21,000.00	28,557.00
9339339	10122200	OASDHI - EMPLOYER COST	14,319.14	15,759.00	19,622.00	14,224.04	17,224.00	22,260.00
9339339	10123000	GROUP INS - EMPLOYER COST	29,004.47	29,451.00	33,976.00	28,245.54	33,887.00	48,895.00
9339339	10124000	WORKERS COMP INS - EMPLOYER COST	6,699.79	5,878.00	5,595.00	5,789.73	5,789.73	7,000.00
9339339	10125000	SUI INS - EMPLOYER COST	439.55	691.00	1,000.00	463.03	700.00	1,000.00
9339339	10128000	HEALTH CARE - RETIREES	763.05	1,525.00	1,914.00	1,595.65	1,750.00	1,952.00
9339339	10140000	COST REDUCTION FACTOR (CalPERS UAL)	273,118.00	-		-	-	0.00
<b>Object 10</b>			<b>548,313.16</b>	<b>297,448.00</b>	<b>340,112.00</b>	<b>253,727.91</b>	<b>306,226.73</b>	<b>400,638.00</b>
9339339	20200500	ADVERTISING/LEGAL NOTICES	489.79	167.00	200.00	174.52	2,174.52	220.00
9339339	20202400	BOOKS/PERIODICAL SUPPLY	-	-				
9339339	20202900	BUSINESS/CONFERENCE EXPENSE	179.78	1,114.00	2,000.00	426.39	1,865.00	2,200.00
9339339	20203100	BUSINESS TRAVEL	-	-				0.00
9339339	20203600	EDUCATION & TRAINING SUPPLIES	-	-		20.00	20.00	0.00
9339339	20203800	EMPLOYEE RECOGNITION	-	-				0.00
9339339	20203807	WORKPLACE AMENITIES	-	-		958.47	958.47	0.00
9339339	20205100	INSURANCE - LIABILITY	51,540.00	63,668.00	73,218.00	72,024.00	72,024.00	80,540.00
9339339	20206100	MEMBERSHIP DUES	2,000.00	5,454.00	5,500.00	6,056.00	6,056.00	6,050.00

9339339	20207600	OFFICE SUPPLIES	402.70	1,106.00	1,500.00	737.56	800.00	1,650.00
9339339	20207602	SIGNS	-	84.00	1,000.00	43.53	43.53	1,100.00
9339339	20207603	KEYS	-	-	200.00	31.25	31.25	220.00
9339339	20208100	POSTAL SERVICES	148.00	188.00	215.00	212.00	212.00	237.00
9339339	20208102	STAMPS	82.16	-	150.00	-	-	165.00
9339339	20208500	PRINTING SERVICES	-	-				0.00
9339339	20210300	AGRICULTURE/HORTICULTURE SERVICE	3,200.00	8,875.00	25,000.00	3,250.00	10,000.00	27,500.00
9339339	20210400	AGRICULTURE/HORTICULTURE SUPPLIES	216.58	417.00	500.00	403.57	403.57	550.00
9339339	20211100	BUILDING MAINTENANCE SERVICE	1,475.00	710.00	1,000.00	4,456.40	6,824.00	2,200.00
9339339	20211200	BUILDING MAINTENANCE SUPPLIES	145.40	175.00	500.00	312.82	312.82	550.00
9339339	20212200	CHEMICAL SUPPLIES	-	-				0.00
9339339	20213100	ELECT MAINT SVC	-	-	1,000.00			1,100.00
9339339	20213200	ELECT MAINT SUPPLIES	-	68.00	200.00			220.00
9339339	20214100	LAND IMPROVEMENT MAINTENANCE SER	7,596.22	5,150.00	10,000.00	9,289.96	19,000.00	11,000.00
9339339	20214200	LAND IMPROVEMENT MAINTENANCE SUP	2,588.61	5,152.00	5,000.00	867.49	1,000.00	5,500.00
9339339	20215100	MECHANICAL SYSTEMS MAINT SERVICE	1,109.00	4,926.00	2,000.00	1,167.00	1,496.00	2,200.00
9339339	20215200	MECHANICAL SYSTEMS MAINT SUPPLIES	-	-	1,000.00	1,151.03	1,151.03	1,100.00
9339339	20216200	PAINTING SUPPLIES	679.87	877.00	1,500.00	782.62	1,000.00	1,650.00
9339339	20216700	PLUMBING MAINTENANCE SERVICES		-	1,000.00	1,720.14	1,720.14	1,100.00
9339339	20216800	PLUMBING MAINTENANCE SUPPLIES	-	-	500.00			550.00
9339339	20218500	PERMIT FEES	-	-				0.00
9339339	20219100	ELECTRICITY	14,476.79	14,668.00	20,000.00	13,726.11	18,471.00	22,000.00
9339339	20219200	NATURAL GAS/LPG/FUEL OIL	2,079.39	2,507.00	3,000.00	4,151.73	4,566.00	3,300.00
9339339	20219300	REFUSE DISPOSAL	2,360.78	3,091.00	3,000.00	1,747.41	2,127.00	3,300.00
9339339	20219500	SEWAGE DISP SVC	821.36	1,895.00	2,000.00	1,381.40	1,658.00	2,200.00
9339339	20219700	TELEPHONE SERVICE	-	-				0.00
9339339	20219800	WATER	28,587.59	26,988.00	35,000.00	17,031.92	22,000.00	38,500.00
9339339	20220500	AUTOMOTIVE MAINTENANCE SERVICE	761.68	2,531.00	3,500.00	2,005.47	2,005.47	3,850.00

9339339	20220600	AUTOMOTIVE MAINTENANCE SUPPLIES	503.32	1,608.00	500.00	2,198.89	2,198.89	550.00
9339339	20221100	CONSTRUCTION EQUIPMENT MAINT Service	4,626.00	2,473.00	4,000.00	3,678.46	4,000.00	4,400.00
9339339	20221200	CONSTRUCTION EQUIPMENT MAINT Supplies	5,874.11	1,267.00	4,000.00	5,413.58	6,000.00	4,400.00
9339339	20222600	EXPENDABLE TOOLS	1,318.10	242.00	500.00	588.57	600.00	550.00
9339339	20223600	FUEL & LUBRICANTS	4,055.96	4,552.00	5,000.00	3,399.70	4,000.00	5,500.00
9339339	20226100	OFFICE EQUIPMENT MAINTENANCE SER	-	-				0.00
9339339	20226200	OFFICE EQUIPMENT MAINTENANCE SUPPLIES NEW Copier Items	-	2,001.00	1,000.00	1,665.78	1,665.78	1,100.00
9339339	20227500	RENT/LEASES EQUIPMENT	-	-	500.00			550.00
9339339	20227501	COPY MACHINE LEASE	3,569.17	563.00	-			0.00
9339339	20227504	MISCELLANEOUS	565.76	202.00	500.00	86.88	200.00	550.00
9339339	20229100	OTHER EQUIPMENT MAINTENANCE SERV	600.00	-	2,000.00			2,200.00
9339339	20229200	OTHER EQUIPMENT MAINTENANCE SUPP	-	-	2,000.00			2,200.00
9339339	20231400	CLOTHING/PERSONAL SUPPLIES	-	27.00	100.00	308.25	308.25	110.00
9339339	20232200	CUSTODIAL SUPPLIES	5,012.63	5,361.00	6,000.00	4,415.67	5,000.00	6,600.00
9339339	20243700	Laboratory (Medical)-Service/Drug Testing	-	-	100.00		50.00	110.00
9339339	20244300	MEDICAL SERVICE		212.00	200.00	168.00	225.00	220.00
9339339	20244400	MEDICAL SUPPLIES	67.33	-	300.00	141.17	141.17	330.00
9339339	20250605	SERVICE FEES (Bank Loan Item)	-	3,506.00	-			0.00
9339339	20250700	ASSESSMENT/COLLECTIONS SERVICES	7,859.64	7,935.00	7,900.00	7,227.92	7,227.92	8,690.00
9339339	20252100	TEMPORARY SERVICES	-	-	-			0.00
9339339	20253100	LEGAL SERVICES	9,407.22	5,568.00	8,000.00	3,525.57	5,000.00	8,800.00
9339339	20255100	PLANNING SERVICES	-	-				10,000.00
9339339	20257100	SECURITY SERVICES	26,110.00	18,850.00	25,000.00	6,863.78	6,863.78	5,000.00
9339339	20258200	PUBLIC RELATIONS SERVICES	2,651.33	1,800.00	2,000.00	1,100.00	1,100.00	1,512.00
9339339	20259100	OTHER PROFESSIONAL SERVICES	4,798.94	(1,500.00)	-	14,090.00	14,090.00	5,500.00
9339339	20281100	DATA PROCESSING SERVICES	2,260.00	2,308.00	2,500.00	108.00	108.00	2,750.00
9339339	20281201	HARDWARE	1,300.64	1,400.00	-	-		0.00
9339339	20281210	PC LAPTOP PRINTER (Copier Purchase)	-	1,401.00	-			0.00

9339339	20281265	APPLICATION SOFTWARE MAINT LICENSE	3,360.46	2,815.00	3,000.00	2,374.99	2,815.00	3,300.00
9339339	20281304	Sales Tax Adj-Board of EQ	-	-	-	-	-	0.00
9339339	20281700	ELECTION SERVICES	1,887.00	-	15,000.00	1,887.00	1,887.00	0.00
9339339	20281900	REGISTRATION SERVICES	-	-	-	-	-	0.00
9339339	20283102	MILEAGE	170.36	86.00	500.00	245.51	306.00	550.00
9339339	20285100	RECREATIONAL SERVICES	-	-	3,000.00	-	-	3,300.00
9339339	20285200	RECREATIONAL SUPPLIES	2,950.35	846.00	3,000.00	2,213.37	2,213.37	3,300.00
9339339	20285300	RECREATIONAL SUPPLIES (P-S) (Used for After School Supplies)	-	-	-	-	-	-
9339339	20289800	OTHER OPERATING EXPENSE - SUPPLIES (Pet Waste Stations / Supplies)	196.52	666.00	200.00	268.25	268.25	220.00
9339339	20289900	OTHER OPERATING EXPENSE - SERVICE (Yrly Fire Extinguisher)	-	109.00	200.00	183.87	183.87	220.00
9339339	20291300	AUDITOR/CONTROLLER SERVICES	5,495.00	5,495.00	6,500.00	6,500.00	6,500.00	7,150.00
9339339	20291500	COMPASS COSTS	987.83	988.00	1,072.00	1,071.83	1,071.83	1,180.00
9339339	20291700	GENERAL SERVICES <b>ALARM SERVICES</b>	1,766.52	1,807.00	2,000.00	3,902.35	3,902.35	4,928.00
9339339	20298700	GS TELEPHONE SERVICES	3,597.77	3,613.00	4,000.00	3,106.38	3,787.00	4,400.00
9339339	20298701	CELL PHONES	987.67	1,809.00	1,500.00	1,225.06	1,414.00	1,650.00
9339339	20299909	EXPENDITURE REIMBURSEMENTS	6,990.00	21,649.00	20,000.00	33,895.77	33,895.77	22,000.00
<b>Object 20</b>			<b>229,910.33</b>	<b>249,470.00</b>	<b>331,755.00</b>	<b>255,983.39</b>	<b>294,943.03</b>	<b>344,572.00</b>
9339339	30321000	INTEREST EXPENSE	9,687.89	8,466.00	7,191.00	6,640.92	7,190.04	5,860.00
9339339	30323000	LEASE OBLIGATION RETIREMENT	27,900.00	29,200.00	30,400.00	27,800.00	30,400.00	31,800.00
9339339	30345000	TAX/LICENSES/ASSESSMENTS	703.64	704.00	704.00	703.64	703.64	775.00
<b>Object 30</b>			<b>38,291.53</b>	<b>38,370.00</b>	<b>38,295.00</b>	<b>35,144.56</b>	<b>38,293.68</b>	<b>38,435.00</b>
9339339	42420100	BUILDINGS	-	-	-	-	-	450,000.00
9339339	42420110	LEASEHOLD IMPROVEMENTS	-	-	-	-	-	-
9339339	42420200	STRUCTURES	-	-	-	-	-	-
<b>Object 42</b>			<b>-</b>	<b>-</b>	<b>-</b>	<b>-</b>	<b>-</b>	<b>450,000.00</b>
	43430300	Equip SD Non Rec	-	28,311.00	-	-	-	-
<b>Object 43</b>			<b>-</b>	<b>28,311.00</b>	<b>-</b>	<b>-</b>	<b>-</b>	<b>-</b>

9339339	45450300	INFRASTRUCTURE-SD-NON-RECON	-	-				
<b>Object 45</b>			-	-				-
9349339	46460300	OTHER INTANGIBLE ASSET-SPEC DIST	-	-				
<b>Object 46</b>			-	-		-	-	-
9339339	79790100	CONTINGENCY APPR	-		555,977.00	-	-	100,000.00
<b>Object 79</b>			-	-	<b>555,977.00</b>	-	-	<b>100,000.00</b>
<b>FUND CENTER 9339339 total expenditures</b>			<b>816,515.02</b>	<b>613,599.00</b>	<b>1,266,139.00</b>	<b>544,855.86</b>	<b>639,463.44</b>	<b>1,333,645.00</b>
			<b>History Expense FY 20-21</b>	<b>History Expense FY 21-22</b>	<b>Actual Adopted 22-23</b>	<b>ACTUAL 22-23 As of 4/30/2023</b>	<b>Ending Projection For FY 22-23</b>	<b>Preliminary Budget FY 23-24</b>

**"Estimated"**

1,333,645.00

Shop Reno (450,000.00)

Savings (100,000.00)

Budgeted for Actual Day to Day Operations 783,645.00



**REVENUE DETAIL SCHEDULE - FY 2023-24 PRELIMINARY BUDGET**

**SPECIAL DISTRICT - ARCADE CREEK RECREATION AND PARK DISTRICT**

Fund Center	Commitment Item	Description	Revenue History 20-21 Received	Revenue History 21-22 Received	Actual Adopted 22-23 Final	ACTUAL 22-23 As of 4/30/2023 Received	Ending Projection FY 22-23 "Estimated"	Preliminary Budget FY 23-24
<b>FUND</b>	<b>339A</b>	<b>ARCADE CREEK REC &amp; PARK DISTRICT</b>						
9339339	91910100	PROP TAX CUR SEC	(620,829.73)	(642,925.41)	(545,236.00)	(674,518.85)	(675,000.00)	(700,000.00)
9339339	91910200	PROP TAX CUR UNSEC	(22,755.24)	(22,234.69)	(23,000.00)	(23,083.65)	(23,083.65)	(23,000.00)
9339339	91910300	PROP TAX CUR SUP	(16,264.77)	(23,580.59)	(17,000.00)	(18,663.22)	(18,663.22)	(18,000.00)
9339339	91910400	PROPERTY TAX SECURED DELINQUENT	(5,161.79)	(4,679.01)	(5,000.00)	(4,123.09)	(4,123.09)	(4,000.00)
9339339	91910500	PROPERTY TAX SUPPLEMENTAL DELINQUENT	(796.27)	(837.98)	(900.00)	(1,575.62)	(1,575.62)	(1,000.00)
9339339	91910600	PROPERTY TAX UNITARY	(5,888.66)	(6,183.24)	(6,000.00)	(6,956.84)	(6,956.84)	(6,000.00)
9339339	91912000	PROP TAX REDEMPTION	(44.50)	(59.18)	(100.00)	(75.54)	(75.54)	(50.00)
9339339	91913000	PROP TAX PR UNSEC	(472.87)	(477.60)	(400.00)	(211.46)	(400.00)	(400.00)
9339339	91914000	PROP TAX PENALTIES	(174.38)	(285.89)	(200.00)	(154.33)	(154.33)	(150.00)
9339339	91919600	RDA RESIDUAL DISTRIBUTION	(13,962.80)	(10,304.75)	(10,000.00)	(5,244.60)	(10,000.00)	(10,000.00)
9339339	91919900	TAXES - OTHER	(0.17)	0.00	0.00	0.00	0.00	0.00
<b>Object 91</b>			<b>(686,351.18)</b>	<b>(711,568.34)</b>	<b>(607,836.00)</b>	<b>(734,607.20)</b>	<b>(740,032.29)</b>	<b>(762,600.00)</b>
9339339	93931000	VEHICLE CODE FINES						0.00
<b>Object 93</b>								<b>0.00</b>
9339339	94941000	INTEREST INCOME	(2,464.98)	(2,531.89)	(1,000.00)	(4,320.00)	(5,000.00)	(2,000.00)
9339339	94942900	BLDG RENTAL OTHER	(59,870.04)	(63,326.04)	(65,326.00)	(51,194.20)	(60,415.00)	(60,000.00)
<b>Object 94</b>			<b>(62,335.02)</b>	<b>(65,857.93)</b>	<b>(66,326.00)</b>	<b>(55,514.20)</b>	<b>(65,415.00)</b>	<b>(62,000.00)</b>
9339339	95952200	HOME PROP TAX REL	(5,548.42)	(5,439.40)	(5,000.00)	(4,491.11)	(5,000.00)	(5,000.00)
9339339	95952900	IN LIEU FEES						0.00
9339339	95953300	REDEV PASSTHRU	(8,131.35)	(7,586.84)	(8,000.00)	(5,351.11)	(7,000.00)	(7,000.00)
9339339	95956300	CONSTRUCTION ST						0.00
9339339	95956900	STATE AID OTHER MISC PROGRAMS						0.00
<b>Object 95</b>			<b>(13,679.77)</b>	<b>(13,026.24)</b>	<b>(13,000.00)</b>	<b>(9,842.22)</b>	<b>(12,000.00)</b>	<b>(12,000.00)</b>
9339339	96964600	RECREATION SVC CHGS						0.00
9339339	96965300	LANDSCAPING MAINT CH						0.00

REVENUE DETAIL SCHEDULE - FY 2023-24 PRELIMINARY BUDGET

SPECIAL DISTRICT - ARCADE CREEK RECREATION AND PARK DISTRICT

Fund Center	Commitment Item	Description	Revenue History 20-21 Received	Revenue History 21-22 Received	Actual Adopted 22-23 Final	ACTUAL 22-23 As of 4/30/2023 Received	Ending Projection FY 22-23 "Estimated"	Preliminary Budget FY 23-24
9339339	96969700	LAW ENFORCEMENT SVC						0.00
<b>Object 96</b>			<b>0.00</b>	<b>0.00</b>	<b>0.00</b>	<b>0.00</b>	<b>0.00</b>	<b>0.00</b>
9339339	97974000	INSURANCE PROCEEDS	(4,990.00)	(17,240.00)	(18,000.00)	(29,895.77)	(29,895.77)	(18,000.00)
9339339	97979000	MISCELLANEOUS OTHER REVENUES	(9,174.13)	(7,310.26)	(5,000.00)	(42,208.07)	(42,208.07)	(5,000.00)
<b>Object 97</b>			<b>(14,164.13)</b>	<b>(24,550.26)</b>	<b>(23,000.00)</b>	<b>(72,103.84)</b>	<b>(72,103.84)</b>	<b>(23,000.00)</b>
9339339	98986200	PROCEEDS FROM ASSET SALE-SPEC. DIST.						
9339339								
<b>Object 98</b>			<b>0</b>	<b>0</b>	<b>0</b>	<b>0</b>	<b>0</b>	<b>0</b>
<b>FUND CENTER 9339339</b>			<b>(776,530.10)</b>	<b>(815,002.77)</b>	<b>(710,162.00)</b>	<b>(872,067.46)</b>	<b>(889,551.13)</b>	<b>(859,600.00)</b>
<b>FUND TOTAL 339A General Fund</b>			<b>(776,530.10)</b>	<b>(815,002.77)</b>	<b>(710,162.00)</b>	<b>(872,067.46)</b>	<b>(889,551.13)</b>	<b>(859,600.00)</b>
			Revenue History 20-21	Revenue History 21-22	Actual Adopted 22-23	ACTUAL 22-23 As of 4/30/2023	Ending Projection FY 22-23 "Estimated"	Preliminary Budget FY 23-24

For Review

FY 2023-24

**339D**

**District Projects**

Preliminary Budget

# Expenditures

## EXPENDITURE DETAIL SCHEDULE - FY 2023-24 PRELIMINARY BUDGI 339D

### SPECIAL DISTRICT - ARCADE CREEK RECREATION AND PARK DISTRICT

Fund Center	Commitment Item	Description	History Expenses FY 2020-21	History Expense FY 21-22	Actual Adopted 22-23	ACTUAL 22-23 As of 4/30/2023	Ending Projection 22-23	FY	Preliminary Budget FY 23-24
FUND	339 D	ARCADE CREEK RECREATION AND PARK DISTRICT	Actual	Actual	Final	Expended			
9339343	20227504	MISCELLANEOUS			31,410.00	31,410.00	31,410.00		
		<b>Object 20</b>			<b>31,410.00</b>	<b>31,410.00</b>	<b>31,410.00</b>		-
	42420100	BUILDINGS	75.25						
9339343	42420110	LEASEHOLD IMP (OAKDALE PARK)		-					-
9339343	42420200	STRUCTURES (ACP Park Improvements)	841.12	53,409.00	322,471.00	165,648.39	165,648.39		156,823.00
		<b>Object 42</b>	<b>916.37</b>	<b>53,409.00</b>	<b>322,471.00</b>	<b>165,648.39</b>	<b>165,648.39</b>		<b>156,823.00</b>
9339343	43430300	EQUIPMENT -SD - NON-RECON (New Play Equip)	-	11,016.00					
		<b>Object 43</b>	-	<b>11,016.00</b>	-	-	-		-
9339343	45450300	INFRASTRUCTURE (BRIDGE PROJECT)	-	-					
		<b>Object 45</b>	-	-	-	-	-		-
9339343	46460300	INTANGIBLES (HSP site plan & location)	-	-					
9339343	46461300	INTANGIBLES	-	-					
		<b>Object 46</b>	-	-	-	-	-		-
<b>FUND CENTER 9339343</b>			<b>916.37</b>	<b>64,425.00</b>	<b>353,881.00</b>	<b>197,058.39</b>	<b>197,058.39</b>		<b>156,823.00</b>
<b>FUND TOTAL 339 D</b>			<b>916.37</b>	<b>64,425.00</b>	<b>353,881.00</b>	<b>197,058.39</b>	<b>197,058.39</b>		<b>156,823.00</b>
			History Expenses FY 2020-21	History Expense FY 21-22	Actual Adopted 22-23	ACTUAL 22-23 As of 4/30/2023	Ending Projection 22-23	FY	Preliminary Budget FY 23-24

<b>EXPENSES DISTRICT TOTAL (supplied by County) 339A + 339D</b>			<b>815,455</b>	<b>877,956</b>					<b>0</b>
---	--	--	----------------	----------------	--	--	--	--	----------

REVENUE DETAIL SCHEDULE - FY 2023-24 PRELIMINARY 339D

District Projects

SPECIAL DISTRICT - ARCADE CREEK RECREATION AND PARK DISTRICT

Fund Center	Commitment Item	Description	Revenue History FY 20-21 Received	Actual Adopted 21-22 Received	Actual Adopted 22-23 Final	ACTUAL 22-23 As of 4/30/2023 Received	Ending Projection FY 22-23	Preliminary Budget FY 23-24
FUND	339 D	ARCADE CREEK REC & PARK DISTRICT						
9339343	94941000	INTEREST INCOME	(253.00)	(720.00)	-	(90.00)		-
9339343	94941105	Contributions Special Dist (SPF/Donations/Etc)	-	-	-		-	
<b>Object 94</b>			<b>(253.00)</b>	<b>(720.00)</b>	<b>-</b>	<b>(90.00)</b>	<b>-</b>	<b>-</b>
9339343	95952900	In Lieu Taxes -	-	-				
9339343	95956300	STATE-FED GRANTS (Dist Proj/Bridge Proj)	-	-				
"	"	STATE-FED GRANTS (Dist Proj/Per Capita Funds)	-	-	(147,427.00)			(128,407.00)
9339343	95956900	STATE AID OTHER MISC PROG (339I-Impact Fees)	(45,000.00)	(45,012.00)	(175,044.00)	(175,044.00)		(28,416.00)
9339343	95956910	STATE MATCH (Umpqua Line of Credit)	-	-			-	
<b>Object 95</b>			<b>(45,000.00)</b>	<b>(45,012.00)</b>	<b>(322,471.00)</b>	<b>(175,044.00)</b>	<b>-</b>	<b>(156,823.00)</b>
9339343	<b>8036000</b>	<b>Appropriations</b>						
<b>FUND CENTER 9339343</b>			<b>(45,253.00)</b>	<b>(45,732.00)</b>	<b>(322,471.00)</b>	<b>(175,134.00)</b>	<b>-</b>	<b>(156,823.00)</b>
<b>FUND TOTAL 339D District Projects</b>			<b>(45,253.00)</b>	<b>(45,732.00)</b>	<b>(322,471.00)</b>	<b>(175,134.00)</b>	<b>-</b>	<b>(156,823.00)</b>
			<b>Revenue History FY 20-21</b>	<b>Actual Adopted 21-22</b>	<b>Actual Adopted 22-23</b>	<b>ACTUAL 22-23 As of 4/30/2023</b>	<b>Ending Projection FY 21-22</b>	<b>Preliminary Budget FY 23-24</b>
<b>REVENUE DISTRICT TOTAL (supplied by County) 339A + 339D</b>			<b>(821,782)</b>	<b>(860,735)</b>	<b>(1,032,633)</b>		<b>0</b>	

<b>Meeting Date</b> <b>May 18, 2023</b>		<b>Item # 7b</b> New Business
<b>Subject:</b> <b>Meeting with Staples Construction</b>		
<b>Initiated or requested by</b> <input type="checkbox"/> Board <input type="checkbox"/> Staff <input type="checkbox"/> Other	<b>Item Type</b> <input checked="" type="checkbox"/> Informational <input type="checkbox"/> Direction <input type="checkbox"/> Action	<b>Report coordinated or prepared by</b>  <i>Lisa Gonzalez</i>
<b>Objective</b> <p>To get clarity on why Staples Construction has been unable to get permits required for the prep work for the restroom building from Sacramento County.</p> <p><b>Background</b> Staples Construction, Public Restroom Company and I have been working on this project for close to a year and have not been able to acquire permits. There have been many attempts to get this project done and failed. Engineers dropped out or were too busy to take the job, a permit expediter who never came through etc. Mike Hanson and I met with JT Turpin and Mark Hodge on April 11, 2023 to discuss our progress. We will be setting up a Microsoft meeting with the Public Restroom Company to see if they can assist us. That call will take place on April 16, 2023 at 9am with myself, JR Turpin, Kate Miller from PRC, and Vice Chair of the Board Michael Hanson. I also reached out to our Project Manager Virg Anderson to see if he can assist. I requested a PDF of the plans be sent to Virg Anderson as he may have some ideas where he may be able to assist. I will report back at the June 15<sup>th</sup> meeting.</p> <p><b>Budget/Cost Information</b>          This project is funded by the Prop 68 grant.</p>		
<b>Coordination and Review</b> This is a standard practice of the Board.	<b>Attachment(s)</b>	

**Arcade Creek Recreation and Park District**

**MEETING DATE: May 18, 2023**

**AGENDA ITEM: 8 Board Discussion**

**General discussion on topics for future meetings.**