

Arcade Creek

Recreation and Park District

BOARD OF DIRECTORS MEETING
THURSDAY JANUARY 19, 2023 @ 6:00 p.m.
At the Herzog Community Center Oak (Small) Room
4855 Hamilton Street, Sacramento, CA 95841

AGENDA

1. **Call to Order and perform Roll Call.** (Chair – Alex Vassar)
2. **Public Comment** – this is the opportunity for members of the public to address the Board on any topic within the Board’s jurisdiction NOT listed on the agenda. The Board will take comments only but cannot act upon any item not listed on the Agenda.
Each speaker will be limited to five minutes of time.
The Board will not receive comments relating to District Personnel during this time. These comments must be made in writing to the General Manager and in the case of the General Manager made in writing to the Chairperson of the Board.
Questions about the daily operation of the park district should be directed to the General Manager during normal working hours when possible.
Comments related to a specific item on the agenda will be received by the Board at that time during the meeting. Members of the public may gain recognition by registering with the Secretary to the Board prior to the start of the meeting or by raising their hand to be recognized by the Chairperson of the Board at the time they wish to speak, and public comment is welcomed.
Although public comments on agenda items are welcomed during each discussion, public comments of a general nature will not be received once the Board Chair has closed the Public Comment period.
3. **Announcements** (Staff)
4. **Task Started, Revised or Accomplished**
5. **Consent Agenda**—*these items are expected to be routine and noncontroversial. Any Board member may ask that an item be removed from the Consent Items list and it will be considered as a separate item under New Business. The Board by motion and second will be asked to approve all items on the list without discussion.*
 - a. **Draft Meeting Minutes:** Board Meeting 12/15/2022
 - b. **FY 22-23 Period 6 Financial Reports 339A**
 - c. **FY 22-23 Period 6 Financial Reports 339D**
 - d. **FY 22-23 Period 6 Multi Accounts Revenue Reports**
 - e. **FY 22-23 Period 6 Payroll Report**
 - f. **FY 22-23 Period 6 Rental & Misc. Revenue Report Attributed To Stated Period**
 - g. **Correspondence received and sent**
 - h. **General Managers Report**
6. **Old Business:**
 - a. Discussion and review of - District Workflow Property Projects, Upgrades, Repairs
 - b. Nominate and vote for Board Officers Positions for 2023

Mailing Address: PO Box 418114, Sacramento, CA 95841-8114
Physical Address: 4855 Hamilton Street, Sacramento, California 95841-3414
(916) 482-8377 Email: acrpd@acrpd.com

6. Old Business: (cont)

- c. Discussion regarding the buildings at Oakdale Elementary (Gym and Community Center Room)
- d. Approval of Amendment to General Manager Employment Agreement Authorizing 80 Hours of Administrative Leave
- e. Sacramento Area Sewer District Final Contract

7. New Business

- a. Contracts from Staples Construction for Hamilton Street Exterior Lighting and Rental Facilities Lighting upgrades, with cost breakdown
- b. AB 361 Replaced with AB 2449 – Limited Teleconferencing in Specified Scenarios
- c. Bereavement Leave – Assembly Bill 1949
- d. Assembly Bill 1041 – Leave Permitted for a “Designated Person”
- e. Board Member to serve on the LAFCo SDAC Council
- f. Discuss possible relocation of District Office to small rental facility or renovate and update the current office
- g. Discuss remove current deck located on the back side of the District Office

8. Board Discussion

- a. General discussion on topics for future meetings

9. Adjournment of the meeting.

The next regular Board of Directors meeting will be held Thursday February 16, 2023, at 6:00 p.m.

NOTICE

Where proper or considered necessary, the Board may act on any item listed on the Agenda; including items listed as information items. Public documents relating to any open session item(s) listed on this agenda that are distributed to the members of the Board of Directors less than 72 hours before the meeting is available for public inspection in the District's Office at 4855 Hamilton Street, Sacramento, CA 95841.

In compliance with the Americans with Disabilities Act, if you have a disability, and you need a related modification or accommodation to take part in this meeting, please contact the Arcade Creek Recreation and Park District office at (916) 482-8377. Requests must be made as early as possible, and at least three full business days (72-hours) before the start of the meeting.

The Agenda is posted on the District's website (www.acrpd.com), are electronically mailed to residents whom have requested an electronic version and are posted for public inspection on the bulletin board just outside the District Office's front door. A full hard copy is available at the front desk a minimum of 72 hours in advance.

Mailing Address: PO Box 418114, Sacramento, CA 95841-8114
Physical Address: 4855 Hamilton Street, Sacramento, California 95841-3414
(916) 482-8377 Email: acrpd@acrpd.com

4. Tasks Started or Accomplished				1/19/2023 Meeting				
<i>File: District Planning Goals/Task Started or Accomplished</i>								
		Priority Legend						
		1 To Do ASAP						
		2 Request John w/Resotration Landscape						
		3 22/23 - Budget Year To Do						
		4 Future Budget Years						
Safety			Appearances			Amenities		
Priority	Description	Status	Priority	Description	Status	Priority	Description	Status
1	Tow sign / tow trucks	COMPLETED	1	Interior lights HSP rental facilities	DIRECTED	2	Remove baseball diamond backstop frame	COMPLETED
2	Park benches/ tables	STARTED	1	ACP - Basketball rims	STARTED	3	Basketball courts @ HSP & ACP	STARTED
3	HSP lights - Park restrooms, facilities, office	STARTED	2	HSP Group picnic area		3	HSP Playground equipment (update/add)	
3	ACP lights - Park restrooms		3	Signs on Jo Smith Nature Trail (Interpretive)		3	Pickle Ball Courts	
4	Creek Erosion		3	Murder House (maint. shop) yard		3	Volleyball courts	
2	Skunk trapping at office 7 skunks caught	COMPLETED	3	Murder House (Maint. Shop)				
			2	Tagging @ HSP 11/5/2022	COMPLETED			
			2	HSP poles & chains removed & holes filled in	COMPLETED			
			1	Additional trees fell down during rain/wind	COMPLETED			

Arcade Creek Recreation & Park District
4855 Hamilton Street, Sacramento, California 95841

MINUTES

Of

The Arcade Creek Recreation & Park District
Meeting of the Board of Directors

Held on

Thursday December 15, 2022 at 6:00 p.m.

Meeting conducted in the Herzog Community Center Maple (Large) Room

Call to Order and Perform Roll Call: Chairperson A. Vassar called the meeting to order at 6:04 pm

Board Members Present: A. Vassar, M Hanson, T. Dworetzky, S. Miller, A. Gualderama (via phone)

Board Members Absent: None

Staff Members Present: Lisa Gonzalez, Kim Cook

Legal Counsel Present: Yes – Derek Cole

Auditor Present: Yes – Larry Bain CPA

Presentation(s): Yes – Report on the final Audit FY 2021-22 from Larry Bain

Visitor(s) That Signed In: None

2. PUBLIC COMMENTS:

None

3. ANNOUNCEMENTS:

None

Regular meeting suspended at 6:05 pm.

Closed session opened at 6:05 pm.

4. CLOSED SESSION:

a. CONFERENCE WITH REAL PROPERTY NEGOTIATORS

Property: Along the Arcade Creek Nature Area and trail. Located behind the lots 5212, 5216 Adelaide Way and 4931 Cameron Ranch Rd., Carmichael, CA

Agency negotiators: Lisa Gonzalez, General Manager, and Derek Cole, General Counsel

Negotiating Parties: Laura Cunningham, Darlis Curtin, Joe Ross

Under Negotiation: Price and terms.

b. CONFERENCE WITH REAL PROPERTY NEGOTIATORS

Property: Assessor Parcel Nos. 230-0080-037 and 230-0080-036

Agency negotiators: Lisa Gonzalez, General Manager, and Derek Cole, General Counsel

Negotiating parties: Sacramento Area Sewer District

MINUTES of Board of Directors Meeting

December 15, 2022

Page 2 of 3

4. CLOSED SESSION: (cont.)

Under negotiation: Price and terms for acquisition of proposed sewer easement and temporary construction easement.

c. CONFERENCE WITH LABOR NEGOTIATORS

Agency designated representatives: Board of Directors Chair

Unrepresented employee: General Manager

Closed session convened at 6:49 pm.

Regular meeting re-opened at 6:49 pm

Director A. Gualderama left the meeting at the conclusion of closed session.

Chair A. Vassar turned the meeting over to Vice-Chair M. Hanson at 6:50 pm and left the meeting.

Report out of closed session:

Direction provided to the General Manager regarding closed session item **a** and **b**.

Direction given to district Legal Counsel regarding closed session item **c**.

5. PRESENTATION(s):

- a. Report from Larry Bain CPA of the FY 2021-22 Annual Audit

Directors and staff received the Audit for FY 2021-22.

6. TASK STARTED, REVISED OR ACCOMPLISHED:

Report received and discussed.

7. CONSENT:

- a. **Draft Meeting Minutes:** Board Meeting 11/17/2022
- b. FY 22-23 Period 5 **Financial Reports 339A**
- c. FY 22-23 Period 5 **Financial Reports 339D**
- d. FY 22-23 Period 5 **Multi Accounts Revenue Reports**
- e. FY 22-23 Period 5 **Payroll Report**
- f. FY 22-23 Period 5 **Rental & Misc. Revenue Report Attributed To Stated Period**
- g. Correspondence **received and sent**
- h. General Managers Report
- i. AB 361 Subsequent Resolution 2022-23

Motion No. 1: It was moved by Director T. Dworetzky and seconded by Director S. Miller to approve consent items.

Motion Carried: 3 Ayes, 0 Noes, 2 Absent, 0 Abstained

Ayes: M. Hanson, T. Dworetzky, S. Miller

Absent: A. Vassar, G. Gualderama

Abstained:

MINUTES of Board of Directors Meeting

December 15, 2022

Page 2 of 3

8. OLD BUSINESS:

- a. Discussion and review of - District Workflow Property Projects, Upgrades, Repairs

Discussion was to reassess and reformat the spreadsheets.

9. NEW BUSINESS:

- a. Approve annual audit report for FY 2021-22 from Larry Bain, C.P.A.

Motion No. 2: It was moved by Director S. Miller and seconded by Director T. Dwortezky accept and approve the Final FY 2021-22 Audit report, as presented in 5 a.

Motion Carried: 3 Ayes, 0 Noes, 2 Absent, 0 Abstained
Ayes: M. Hanson, T. Dwortezky, S. Miller
Absent: A. Vassar, G. Gualderama
Abstained:

- b. Discussion of Nominations for Board Officers Position for 2023

The Directors were informed that during the January 2023 board meeting it would be time to elect seats for the Chairperson, Vice-Chair and Secretary/Treasurer or maintain the status quo.

- c. Discussion regarding the buildings at Oakdale Elementary (Gym and Community Center Room)

Directors requested this be brought back and placed on the January 2023 meeting.

10. BOARD DISCUSSION:

- a. General discussion on topics for future meetings.

It was requested to conduct the January board meeting in the small rental facility.

Suggested items to discuss were the possibility of relocating the current district office to the small rental facility or renovating and updating the current office.

Removing the current deck located on the back side of the district office.

11. ADJOURNMENT OF THE MEETING.

Vice-Chair adjourned the meeting at 7:56 pm.

**ACRPD 2022 - 2023
339A Budget Report**

**December 2022
Period 6 of 13**

FYTD Completed = 46%

	CODE	CATEGORIES	2022-23 Budget	December	Expended To Date	Balance	Percent Expended
1	10111000	Salaries and Wages - Reg F/T Staff	200,480.00	16,768.24	98,428.42	102,051.58	49%
2	"	Part-time Salaries			-		-0-
3	"	P/T Monitors & Maint.	48,510.00	1,445.06	10,420.31	38,089.69	21%
4	"	Blank			-	-	#DIV/0!
5	"	Blank			-	-	#DIV/0!
6	"	Blank			-	-	#DIV/0!
7	10112400	Salaries & Wages - Commission & Brds	3,500.00	450.00	1,550.00	1,950.00	44%
8	10113200	Salaries & Wages - Time/one half (OT)	4,000.00	51.98	999.91	3,000.09	25%
9	"	Salary/Wages - Strt Time (No Retirement Contribution)		132.83	728.07	(728.07)	#DIV/0!
10	10121000	Retirement - Employer Cost (@10.32%)	11,824.00	991.68	5,813.86	6,010.14	49%
11	"	Retirement - Employer Cost (@8.63%)	7,414.00	617.82	3,634.05	3,779.95	49%
12	"	Retirement - UAL (110.08 mthly or 1277.00)	1,277.00		1,277.00	-	100%
13	"	Retirement Actuarial Cost	1,000.00		350.00	650.00	35%
14	10122000	Social Security (OASDHI rate=7.65%)	19,622.00	1,441.87	8,577.67	11,044.33	44%
15	10123000	Group Insurance - Employer Cost			-	-	-0-
16	"	Medical + Admin fee	32,032.00	2,580.23	15,484.96	16,547.04	48%
17	"	Dental	1,516.00	125.37	883.35	632.65	58%
18	"	Vision	297.00	24.57	171.99	125.01	58%
19	"	EAP	131.00	-	52.20	78.80	40%
20	10124000	Work Comp Ins - Employer Cost	5,595.00	1,863.48	4,480.98	1,114.02	80%
21	10125000	State Unemployment Insurance (Pool)	1,000.00	-	47.71	952.29	5%
22	10128000	Health Care Retirees	1,914.00	153.80	980.45	933.55	51%
23	10140000	Cost Reduct Factor (CalPERS UAL Pre Pmt)			-	-	#DIV/0!
24		TOTALS:	340,112.00	26,646.93	153,880.93	186,231.07	45%

**ACRPD 2022 - 2023
339A Budget Report**

**December 2022
Period 6 of 13**

FYTD Completed = 46%

	CODE	Service & Supply	2022-23 Budget	December	Expended To Date	Balance	Percent Expended
25	20200500	Advertising/Legal Notices	200.00		-	200.00	0%
26	20202900	Business/Conference Expenses	2,000.00	114.03	114.03	1,885.97	6%
27	20203600	Education and Training Supplies	-		20.00	(20.00)	#DIV/0!
28	20203804	Workplace Amenities	-	734.35	958.47	(958.47)	#DIV/0!
29	20205100	Insurance - Liability	73,218.00	36,012.00	72,024.00	1,194.00	98%
30	20206100	Memberships Dues	5,500.00	3,391.00	6,056.00	(556.00)	110%
31	20207600	Office Supplies	1,500.00		387.08	1,112.92	26%
32	20207602	Signs	1,000.00		59.69	940.31	6%
33	20207603	Keys	200.00		-	200.00	0%
34	20208100	Postage Service (PO Box)	215.00		212.00	3.00	99%
35	20208102	Stamps (Postal)	150.00		-	150.00	0%
36	20208500	Printing Service	-		-	-	#DIV/0!
37	20210300	Agriculture/Horticultural Services	25,000.00	2,700.00	5,950.00	19,050.00	24%
38	20210400	Agricultural/Horticultural Supplies	500.00		-	500.00	0%
39	20211100	Building Maintenance Service	1,000.00	512.00	2,993.40	(1,993.40)	299%
40	20211200	Building Maintenance Supplies	500.00		-	500.00	0%
41	20212200	Chemical Supplies (new)	-		-	-	#DIV/0!
42	20213100	Electrical Maintenance Services	1,000.00		-	1,000.00	0%
43	20213200	Electrical Maintenance Supplies	200.00		-	200.00	0%
44	20214100	Land Improvement Maintenance Service	10,000.00		4,895.00	5,105.00	49%
45	20214200	Land Improvement Maintenance Sup.	5,000.00		527.43	4,472.57	11%
46	20215100	Mechanical System Maintenance Svcs.	2,000.00	229.00	938.00	1,062.00	47%
47	20215200	Mechanical System Maintenance Sup.	1,000.00		1,151.03	(151.03)	115%
48	20216200	Painting Supplies	1,500.00	173.02	173.02	1,326.98	12%
49	20216700	Plumbing Maintenance Service (new)	1,000.00		678.69	321.31	68%
50	20216800	Plumbing Maintenance Supplies	500.00		-	500.00	0%
51	20218500	Permit Charges	-		-	-	#DIV/0!
52	20219100	Electricity	20,000.00	1,074.16	9,543.81	10,456.19	48%

**ACRPD 2022 - 2023
339A Budget Report**

**December 2022
Period 6 of 13**

FYTD Completed = 46%

	CODE	Service & Supply	2022-23 Budget	December	Expended To Date	Balance	Percent Expended
53	20219200	Natural Gas Service	3,000.00	460.99	542.57	2,457.43	18%
54	20219300	Refuse Collection/Disposal	3,000.00	189.90	1,035.22	1,964.78	35%
55	20219500	Sewage Services	2,000.00	276.28	828.84	1,171.16	41%
56	20219800	Water	35,000.00	2,682.69	12,370.39	22,629.61	35%
57	20220500	Automotive Maintenance Service	3,500.00	39.90	510.75	2,989.25	15%
58	20220600	Automotive Maintenance Supplies	500.00	193.84	335.96	164.04	67%
59	20221100	Grounds Equipment Maintenance Svcs.	4,000.00		1,534.70	2,465.30	38%
60	20221200	Grounds Equipment Maintenance Sup.	4,000.00	107.73	2,623.72	1,376.28	66%
61	20222600	Hand / Expendable Tools	500.00		434.60	65.40	87%
62	20223600	Fuel and Lubricant Supplies	5,000.00	220.20	2,251.19	2,748.81	45%
63	20226200	Office Equip. Maintenance Supplies	1,000.00		512.87	487.13	51%
64	20227500	Rent/Lease Equipment	500.00		-	500.00	0%
65	20227501	Copy Machine - Lease	-		-	-	#DIV/0!
66	20227504	Miscellaneous	500.00	28.96	86.88	413.12	17%
67	20229100	Other Equip Maint. Service	2,000.00		-	2,000.00	0%
68	20229200	Other Equip Maint. Supply	2,000.00		-	2,000.00	0%
69	20231400	Clothing/Personal Supplies	100.00	234.57	308.25	(208.25)	308%
70	20232200	Custodial Supplies	6,000.00	239.22	1,461.63	4,538.37	24%
71	20243700	Lab (Medical) Service (Drug Testing)	100.00		-	100.00	0%
72	20244300	Medical Service (Pre-emp. testing)	200.00		136.00	64.00	68%
73	20244400	Medical Supplies (First Aid)	300.00	7.14	141.17	158.83	47%
74	20250605	Service Fees (Bank Loan Item)	-		-	-	#DIV/0!
75	20250700	Assessment / Collection Services	7,900.00		109.00	7,791.00	1%
76	20252100	Temporary Services	-		-	-	#DIV/0!
77	20253100	Legal Services	8,000.00	517.50	1,838.07	6,161.93	23%
78	20255100	Planning Service-	-		-	-	#DIV/0!
79	20257100	Security Service	25,000.00		6,863.78	18,136.22	27%
80	20258200	Public Relations Service/mkting, web	2,000.00		1,100.00	900.00	55%

**ACRPD 2022 - 2023
339A Budget Report**

**December 2022
Period 6 of 13**

FYTD Completed = 46%

	CODE	CATEGORIES	2022-23 Budget	December	Expended To Date	Balance	Percent Expended
81	20259100	Other Professional Services	-		13,480.00	(13,480.00)	#DIV/0!
82	20281100	Data Processing -Computer Services	2,500.00		-	2,500.00	0%
83	20281201	Hardware (Computer)	-		-	-	#DIV/0!
84	20281210	PC Laptop Printer (Copier) Purchase	-		-	-	#DIV/0!
85	20281265	Application Software Maint Lic Renewal	3,000.00	220.00	1,419.99	1,580.01	47%
86	20281304	Sales Tsx Adj - Board of EQ			-	-	#DIV/0!
87	20281700	Election Services	15,000.00	1,887.00	1,887.00	13,113.00	13%
88	20283102	Mileage	500.00	21.23	139.53	360.47	28%
89	20285100	Recreation Services	3,000.00		-	3,000.00	0%
90	20285200	Recreation Supplies	3,000.00		1,744.90	1,255.10	58%
91	20285300	Recreation Supp. (P-S) ELP Program			-	-	#DIV/0!
92	20288000	Prior Year Service & Supply Expe	-		-	-	#DIV/0!
93	20289800	Other Operating Expenses - Supplies	200.00		235.96	(35.96)	118%
94	20289900	Other Operating Exp. - Misc. expenses	200.00		183.87	16.13	-0-
95	20291300	Auditor/Controller Services	6,500.00	6,500.00	6,500.00	-	100%
96	20291500	Compass Costs	1,072.00		1,071.83	0.17	100%
97	20291700	Alarm Services	2,000.00	210.00	2,484.59	(484.59)	124%
98	20298700	Telephone Services	4,000.00	301.41	1,819.04	2,180.96	45%
99	20298701	Cell Phones	1,500.00	62.75	973.78	526.22	65%
100	20299909	Expenditure Reimbursements (Insurance Clair	20,000.00		19,945.77	54.23	100%
101		TOTALS:	331,755.00	\$ 59,340.87	\$ 193,593.50	\$ 138,161.50	58%

20259100 Other Prof Services - Expensed New Surveillance Cameras & Alarmed Rental Facility Buildings

20289800 Other Operating Expenses - Supplies - Also being used as an expence line for items that will be transferred to 339D via a JV

**ACRPD 2022 - 2023
339A Budget Report**

**December 2022
Period 6 of 13**

FYTD Completed = 46%

	CODE	CATEGORIES	2022-23 Budget	December	Expended To Date	Balance	Percent Expended
102	30321000	Interest Expense	7,191.00	594.88	4,351.84	2,839.16	61%
103	30323000	Lease Obligation Retirement(Side Fund)	30,400.00	2,500.00	17,500.00	12,900.00	58%
104	30345000	Taxes, Licenses & Assessments	704.00	-	703.64	0.36	100%
	TOTALS:		38,295.00	\$ 3,094.88	\$ 22,555.48	\$ 15,739.52	59%

FYTD Completed = 46%

	CODE	CATEGORIES	2022-23 Budget	December	Expended To Date	Balance	Percent Expended
105	42420100	Building - Community Ctr Upgrades			-	-	#DIV/0!
106	43430300	Equipment SD Maint Equip			-	-	#DIV/0!
107	TOTALS:		-	\$ -	\$ -	\$ -	#DIV/0!

FYTD Completed = 46%

108	79790100	Contingencies	555,977.00		-	\$ 555,977.00	0%
109		Reserved Fund Balance Increase			-	\$ -	0%
110	Grand Total		\$ 1,266,139.00	\$ 89,082.68	\$ 370,029.91	\$ 896,109.09	29%

*Grand Total includes
GL79790100 Contingencies
amount*

	Beginning Fund Balance Available			-	\$ -	0%
	Fund Balance Decreased by				\$ -	0%
	Provisions for General Reserves		-		\$ -	0%
	TOTALS:		-	-	-	-

ACRPD 2022 - 2023
339A Revenue

December 2022
Period 6 of 13

FYTD Completed = 46%
Percent Received

Account		2022-23 Budget	December	Received To Date	Unrealized	
1	91910100	Property Tax-Current Secured	545,236.00		-	545,236.00 0%
2	91910200	Property Tax-Current Unsecured	23,000.00		(0.09)	23,000.09 0%
3	91910300	Property Tax-Current Sup.	17,000.00		-	17,000.00 0%
4	91910400	Property Tax Sec. Delin.(+Teeter)	5,000.00	4,123.09	4,123.09	876.91 82%
5	91910500	Property Tax Supplemental Delin.	900.00	1,575.62	1,575.62	(675.62) 175%
6	91910600	Property Tax-Unitary	6,000.00		-	6,000.00 0%
7	91912000	Redemption	100.00		-	100.00 0%
8	91913000	Property Tax Prior Unsecured	400.00		-	400.00 0%
9	91914000	Penalty	200.00		2.68	197.32 1%
10	91919600	RDA Residual Distribution	10,000.00		369.20	9,630.80 4%
11	91919900	Taxes - Other				- #DIV/0!
12		Total Taxes	\$ 607,836.00	\$ 5,698.71	6,070.50	\$ 601,765.50 1%
13	94941000	Interest	1,000.00		-	1,000.00 0%
14	94942900	Building Rental (Parks & Facilities)	10,001.00	(60.00)	2,040.00	7,961.00 20%
15	"	Building Rental (Cell Towers 4610.42)	55,325.00	9,220.84	27,662.52	27,662.48 50%
16	95952200	Homeowner Property Tax Relief	5,000.00	792.55	792.55	4,207.45 16%
17	95952900	In Lieu Taxes - Other	-		-	- #DIV/0!
18	95953300	Redevelopment Passthru	8,000.00		227.65	7,772.35 3%
19	95956300	State-Federal Grants			-	- #DIV/0!
20	95956900	Other Funds - Local (GRANT)			-	- #DIV/0!
21	"	Grant = Park Sponsorships			-	- #DIV/0!
22	"	Funds Transferred from 339I			-	- #DIV/0!
23	"	Blank			-	- #DIV/0!
24	96964600	Recreation Fees			-	- #DIV/0!
25	97974000	Insurance Proceeds	18,000.00		17,945.77	54.23 100%
26	97979000	Miscellaneous	5,000.00	25.27	25.27	4,974.73 1%
27	97979900	Prior Year (Funds moved to)			-	- #DIV/0!
28	98986200	Proceeds from Asset sale - Spec Dist			-	- #DIV/0!
29		Fund Balance Available =xxxxxxx.xx			-	- #DIV/0!
30	Problem	**County Error In Process of Correction**	-	-	-	- 0%
31		Total Other Revenue	\$ 102,326.00	\$ 9,978.66	\$ 48,693.76	\$ 53,632.24 48%
32		Total Revenue	\$ 710,162.00	\$ 15,677.37	\$ 54,764.26	\$ 655,397.74 8%

Note: Per Resolution 2022-22 via JV 110777002, Short term loan of \$147,427.55 provided to 339D GL 5250000 by 339A GL 1800000
 339A 5 b i FY 2022 - 2023 Finance 339A.xls 1/6/2023

Register Expense Report
Period 6
Account

FY 2022-2023
12/1/2022 Through 12/31/2022
339A

**Not
Clrd**

Date	Num	Description	Memo	Category	Clrd	Amount
12/2/2022	24553	S CalPERS - 521	11/16 - 11/30/2022 EE Contrib	05420514 Retirement (EE Contribution)	c	(336.33)
			11/16 - 11/30/2022 ER Contrib	121000 Retirement ER Cost	c	(495.84)
12/2/2022	24554	S CalPERS - 521	11/16 - 11/30/2022 EE Contrib	05420514 Retirement (EE Contribution)	c	(250.56)
			11/16 - 11/30/2022 ER Contrib	121000 Retirement ER Cost	c	(308.91)
12/2/2022	24555	Central Control System - 23278	12/2022 - Wireless irrigation	281265 Application Software Maint. Lic	c	(220.00)
12/2/2022	24556	Cintas - 56036	11/23/2022 Custodial	232200 Custodial Supplies	c	(116.52)
12/2/2022	24557	CSDA - 8529	2023 - Membership Dues	206100 Membership Dues	c	(3,391.00)
12/2/2022	24558	Fast Break - 37998	11/2022 Phone service	298700 Telephone Services	c	(195.00)
12/2/2022	24559	S Home Depot - 2843	GE Fridge - Office	203804 Workplace Amenities	c	(644.35)
			Protection Plan 3 yr GE Fridge	203804 Workplace Amenities	c	(90.00)
12/2/2022	24560	Home Depot - 2843	2/Circular saw blades	221200 Ground Equip Maint. Supplies	c	(107.73)
12/2/2022	24561	S Home Depot - 2843	Paint Supplies	216200 Painting Supplies	c	(176.29)
			2% Prompt pmt discount	216200 Painting Supplies	c	3.27
12/2/2022	24562	Kim Cook - 919996	Adjusted mileage rate on prior reimbursements	283102 Mileage	c	(4.96)
12/2/2022	24563	Kim Cook - 919996	11/2022 Mileage reimb	283102 Mileage	c	(13.88)
12/2/2022	24564	Lisa Gonzalez - 932917	Adjusted mileage rate on prior reimbursements	283102 Mileage	c	(2.39)
12/2/2022	24565	S OK Tire - 14277	Labor - 2010 Ford	220500 Automotive Maint. Service	c	(39.90)
			Parts - 2010 Ford - Tire Sensor	220600 Automotive Maint. Supplies	c	(193.84)
12/2/2022	24566	Orbit Station - 33714	11/2022- Fuel Chgs	223600 Fuel & Lubricant Supplies	c	(220.20)
12/2/2022	24567	PG&E - 1383	11/2022 - Billing	219200 Natural Gas Service	c	(460.99)
12/2/2022	24568	Raul's Tree Care - 69419	HSP Stump grinding 19 various sizes	210300 Agriculture-Horticultural Service	c	(2,700.00)
12/2/2022	24569	Sacramento Suburban Water - 26158	11/2022 - Myrtls (Oak)	219800 Water	c	(840.90)
12/2/2022	24570	Sacramento Suburban Water - 26158	11/2022 - HSP	219800 Water	c	(169.61)
12/2/2022	24571	S T-Mobile - 32685	11/2022 - District Cell Phone	298701 Cell Phones	c	(29.41)
			GM phone (purchase pmt)	298701 Cell Phones	c	(33.34)
12/2/2022	24572	S Umpqua CC - 71085	11/5/2022 Board Retreat Lunch	202900 Business Conference Expenses	c	(114.03)
			Staff shirts	231400 Clothing - Personal Supplies	c	(234.57)
			Replenish first aid supplies	244400 Medical Supplies (First Aid)	c	(7.14)
12/8/2022	24573	CAPRI - 8761	3rd Qtr W/C FY 2022-23	124000 Workers Comp	c	(1,308.75)
12/8/2022	24574	CAPRI - 8761	7/2022-6/2023 -2nd half Liability Ins Coverage	205100 Insurance - Liability	c	(36,012.00)
12/8/2022	24575	Cintas - 56036	12/7/2022 Custodial	232200 Custodial Supplies	c	(116.52)
12/8/2022	24576	Republic Services - 57909	11/2022 - Billing	219300 Refuse Collection-Disposal	c	(189.90)
12/8/2022	24577	Sacramento County utilities - 666	10/22 -12/21/2022- Billing	219500 Sewage Services	c	(276.28)
12/8/2022	24578	SMUD - 4025	11/2022 - SMUD Billing	219100 Electricity	c	(1,074.16)
12/15/2022	EFT	# 400043889 - Health Benefits	Health Benefits Pay Date 12/15/2022	123000 Health Insurance(s)	c	(1,285.59)

				Date Printed	1/6/2023		
12/15/2022	P/R+Taxes	S	Payroll And Taxes	Period 11/16/2022 - 11/30/2022 - Ck date 12/15/2022	111000 Salaries & Wages	c	(9,104.68)
				Brd Pay Ck date 12/15/2022	112400 Stipend Commission & Board	c	(200.00)
				Time/One Half - Ck date 12/15/2022	113200 OT & Straight Time	c	-
				OT Straight Pay - Ck date 12/15/2022	113200 OT & Straight Time	c	-
				OASDHI - Ck date 12/15/2022	122000 OASDHI	c	(711.80)
				SUI ER Contrib Ck date 12/15/2022	125000 SUI Insurance (ER Cost)	c	-
				Termination Pay	115200 Terminal Pay	c	-
12/15/2022	24579		CAPRI - 8761	Final W/C FY 2021-22	124000 Workers Comp	c	(554.73)
12/15/2022	24580		Clarke & Rusch - 8939	11/8/2022 Planned Maint.	215100 Mechanical Sys Maint. Services	c	(229.00)
12/15/2022	24581		Cole Huber - 54641	11/2022 Ref:ACP Property	253100 Legal Services	c	(517.50)
12/15/2022	24582		Comcast - 12322	12/2022-Billing-Phone/HSI	298700 Telephone Services	c	(106.41)
12/15/2022	24583		Crime Alert Security - 41852	1/2023 - 3/31/2022 Alarm System Office & Shop	291700 Alarm Services	c	(210.00)
12/15/2022	24584		Defender Termite & Pest - 71461	12/2022 - HSP Pest Control	211100 Building Maint. Service	c	(70.00)
12/15/2022	24585		Defender Termite & Pest - 71461	12/2022 - Oakdale RR Pest Control	211100 Building Maint. Service	c	(72.00)
12/15/2022	24586		Larry Bain, CPA - 26727	FY 21/22 - Audit	291300 Auditor Controller Services	c	(6,500.00)
12/15/2022	24587		Sacramento Suburban Water - 26158	12/2022 - Garfield (ACP)	219800 Water	c	(724.42)
12/15/2022	24588		Sacramento Valley Wildlife Services - 6	Placement Skunk Trap @ HSP	211100 Building Maint. Service	c	(245.00)
12/15/2022	24589		Sacramento Valley Wildlife Services - 6	Skunk Removal	211100 Building Maint. Service	c	(125.00)
12/15/2022	24590	S	Smart & Final - 22935	4 cases water for staff	227504 Misc (Bottled Water for Staff)	c	(28.96)
				Skunk Deodorizer Items	232200 Custodial Supplies	c	(6.18)
12/20/2022	24591	S	CalPERS - 521	12/1 - 12/15/2022 EE Contrib	05420514 Retirement (EE Contribution)	c	(336.33)
				12/1 - 12/15/2022 ER Contrib	121000 Retirement ER Cost	c	(495.84)
12/20/2022	24592	S	CalPERS - 521	12/1 - 12/15/2022 EE Contrib	05420514 Retirement (EE Contribution)	c	(250.56)
				12/1 - 12/15/2022 ER Contrib	121000 Retirement ER Cost	c	(308.91)
12/20/2022	24593	S	CalPERS Health - 12733	1/2023 - Medical - 3 EE's	5420516 Insurance (Clearing Acct)	c	(2,741.22)
				1/2023 - Medical - EE Admin Fee	123000 Health Insurance(s)	c	(9.05)
				1/2023- Medical - 2 Retirees	128000 Retiree Health Benefits	c	(153.80)
12/20/2022	24594	S	GSRMA - 29229	1/2023 - Dental - 3 EEs	123000 Health Insurance(s)	c	(125.37)
				1/2023 -Vision - 3 EEs	123000 Health Insurance(s)	c	(24.57)
12/20/2022	24595		Sacramento Suburban Water - 26158	12/2022 - Myrtle (Oak)	219800 Water	c	(947.76)
12/20/2022	24596		Sacramento Suburban Water - 26158	12/2022 - HSP	219800 Water		(160.39)
12/20/2022	DepPermit	S	County Of Sacramento Deposit Permit	Studio / Field Space	942900 Building Rental + Other	c	-
				Event Building / GPA / Park Rentals	942900 Building Rental + Other	c	-
				Cell Tower	942900 Building Rental + Other	c	4,610.42
				Grants -	956300 State - Federal Grants	c	-
				Misc Funds Collected / Received	979000 Misc Other Revenues	c	-
				Rental Refunds	942900 Building Rental + Other	c	-
12/27/2022	24597		Cintas - 56036	12/21/2022 Custodial	232200 Custodial Supplies		(116.52)
12/27/2022	24598		County Of Sacramento - Voter Registra	2022 Election Cost	281700 Election Services	c	(1,887.00)
12/27/2022	24,599.00		Crime Alert Security - 41852	A/o 1/2023 - 3/31/2022 Alarm System Shop	291700 Alarm Services		(30.00)
12/27/2022	24600		Crime Alert Security - 41852	Upgrade Shop to LE4000E Universal Communicator	259100 Other Professional Services		(260.00)
12/27/2022	24601	S	Dave Weber - 54010	Post Removal @ HSP	214100 Land Improvement Maint. Services		(550.00)

12/27/2022	24602	S	Umpqua Bank - 52152	Demolished Concrete Picnic Tables @ HSP	214100 Land Improvement Maint. Services	(1,500.00)
				1/2023 - Side Fund Interest	321000 Interest Expense	c (594.88)
				1/2023 - Side Fund Principal	323000 Lease Oblig Retirement Side Fur	c (2,500.00)
12/30/2022	EFT		# 400043979 - Health Benefits	Health Benefits Pay Date 12/30/2022	123000 Health Insurance(s)	c (1,285.59)
12/30/2022	P/R+Taxes	S	Payroll And Taxes	Period 12/1/2022 - 12/15/2022 - Ck date 12/30/2022	111000 Salaries & Wages	c (9,108.62)
				Brd Pay Ck date 12/30/2022	112400 Stipend Commission & Board	c (250.00)
				Time/One Half - Ck date 12/30/2022	113200 OT & Straight Time	c (51.98)
				OT Straight Pay - Ck date 12/30/2022	113200 OT & Straight Time	c (132.83)
				OASDHI - Ck date 12/30/2022	122000 OASDHI	c (730.07)
				SUI ER Contrib Ck date 12/30/2022	125000 SUI Insurance (ER Cost)	c -
				Termination Pay	115200 Terminal Pay	c -
12/31/2022	TaxRevenu	S	Property Tax(s) Deposited Per County C	12/2022 - Property Tax - Current Secured	910100 Prop Tax Current Secured	c -
				12/2022 - Property Tax - Current Unsecured	910200 Prop Tax Current Unsecured	c -
				12/2022 - Property Tax - Current Sup.	910300 Prop Tax Current Sup	c -
				12/2022 - Property Tax Sec Delin.(+Tetter)	910400 Prop Tax Sec Delinquent + Teeter	c 4,123.09
				12/2022 - Property Tax Supplement Delin.	910500 Prop Tax Supplemental Delinquen	c 1,575.62
				12/2022 - Properry Tax-Unitary	910600 Prop Tax Unitary	c -
				12/2022 - Redemption	912000 Prop Tax Redemption	c -
				12/2022 - Property Tax Prior Unsecured	913000 Prop Tax Prior Unsecured	c -
				12/2022 - Penalty	914000 Prop Tax Penalties	c -
				12/2022 - RDA Residual Distribution	919600 RDA Residual Distribution	c -
				12/2022 - Interest	941000 Interest	c -
				12/2022 - Homeowner Property Tax Relief	952200 Homeowner Prop Tax Relief	c 792.55
				12/2022 - Redevelopment Passthru	953300 Redevelopment Passthru	c -
				12/2022 -Taxes Other	919900 Taxes Other	c -
					TOTAL 12/1/2022 - 12/31/2022	(84,512.91)
					BALANCE 12/31/2022	(342,940.85)
					TOTAL INFLOWS	11,104.95
					TOTAL OUTFLOWS	(95,617.86)
					NET TOTAL	(84,512.91)

Quicken (In House Ledger)

339A General Budget

7/1/2022 thru 12/31/2022

Date	Num	Description	Memo	Clr	Amount
EXPENSES					
202900 Business Conference Expenses					
12/2/2022	24572	S Umpqua CC - 71085	11/5/2022 Board Retreat Lunch	c	(114.03)
TOTAL 202900 Business Conference Expenses					(114.03)
203600 Education & Training Supplies					
11/3/2022	24532	S Umpqua CC - 71085	CSDA Brown Act Compliance Manual 2nd Edition	c	(20.00)
TOTAL 203600 Education & Training Supplies					(20.00)
203804 Workplace Amenities					
11/14/2022	24539	S Home Depot - 2843	Microwave (office)	c	(224.12)
12/2/2022	24559	S Home Depot - 2843	GE Fridge - Office	c	(644.35)
			Protection Plan 3 yr GE Fridge	c	(90.00)
TOTAL 203804 Workplace Amenities					(958.47)
205100 Insurance - Liability					
7/12/2022	24379	CAPRI - 8761	7/2022-6/2023 -1st half Liability Ins Coverage	c	(36,012.00)
12/8/2022	24574	CAPRI - 8761	7/2022-6/2023 -2nd half Liability Ins Coverage	c	(36,012.00)
TOTAL 205100 Insurance - Liability					(72,024.00)
206100 Membership Dues					
7/12/2022	24377	CARPD - 70968	FY 2022-23 Dues	c	(2,500.00)
9/7/2022	24458	S Umpqua CC - 71085	1 Yr Memberhsip - CPRS L Gonzalez	c	(165.00)
12/2/2022	24557	CSDA - 8529	2023 - Membership Dues	c	(3,391.00)
TOTAL 206100 Membership Dues					(6,056.00)
207600 Office Supplies					
7/20/2022	24397	Staples Business Advantage - 14122	Office supplies	c	(179.07)
7/26/2022	24405	Staples Business Advantage - 14122	Office supplies	c	(75.26)
10/20/2022	24514	Staples Business Advantage - 14122	Office supplies	c	(108.22)
11/3/2022	24532	S Umpqua CC - 71085	Office ink stamps	c	(24.53)
TOTAL 207600 Office Supplies					(387.08)
207602 Signs					
8/10/2022	24424	S Umpqua CC - 71085	Private Property Signs	c	(32.31)
11/14/2022	24539	S Home Depot - 2843	No Trespassong signs	c	(11.22)

				TOTAL 207602 Signs	(43.53)
207603 Keys					
10/24/2022	24515	S	J&J Locksmith - 1833	Keys	c (16.16)
				TOTAL 207603 Keys	(16.16)
208100 Postage Service (PO Box)					
8/10/2022	24424	S	Umpqua CC - 71085	1 Yr District Postal Box	c (212.00)
				TOTAL 208100 Postage Service (PO Box)	(212.00)
210300 Agriculture-Horticultural Service					
7/5/2022	24364		Dave Weber - 54010	ACP trai / Oak Remove playground partl	c (850.00)
10/13/2022	24503		Raul's Tree Care - 69419	HSP Removal split Valley Oak/ clean up utility lines near office	c (1,500.00)
10/13/2022	24504		Raul's Tree Care - 69419	ACP Remove 3 dead Valley Oaks/Street clearance on parking	c (900.00)
12/2/2022	24568		Raul's Tree Care - 69419	HSP Stump grinding 19 various sizes	c (2,700.00)
				TOTAL 210300 Agriculture-Horticultural Service	(5,950.00)
211100 Building Maint. Service					
7/25/2022	24399		Defender Termite & Pest - 71461	7/2022 - HSP Pest Control	c (70.00)
7/25/2022	24400		Defender Termite & Pest - 71461	7/2022 - Oakdale RR Pest Control	c (72.00)
8/2/2022	24413		Restoration Landscape - 71858	HSP Vandalism 7/20/2022 -Shore broken window Sm Rm	c (495.00)
8/2/2022	24414		Restoration Landscape - 71858	HSP Vandalism 8/1/2022 -Shore upper window @ shop	c (1,025.00)
9/7/2022	24456		Southgate Glass, Inc / Carmichael - 5461	Replace window HSP Sm Rm Vandalism 7/20/2022	c (677.40)
9/26/2022	24474		Defender Termite & Pest - 71461	9/2022 - HSP Pest Control	c (70.00)
9/26/2022	24475		Defender Termite & Pest - 71461	9/2022 -Oakdale RR Pest Control	c (72.00)
12/15/2022	24584		Defender Termite & Pest - 71461	12/2022 - HSP Pest Control	c (70.00)
12/15/2022	24585		Defender Termite & Pest - 71461	12/2022 - Oakdale RR Pest Control	c (72.00)
12/15/2022	24588		Sacramento Valley Wildlife Services - 65804	Placement Skunk Trap @ HSP	c (245.00)
12/15/2022	24589		Sacramento Valley Wildlife Services - 65804	Skunk Removal	c (125.00)
				TOTAL 211100 Building Maint. Service	(2,993.40)
211200 Building Maint. Supplies					
9/26/2022	24477		Home Depot - 2843	HSP - Lighting Fixtures - Main Office	c (180.35)
				TOTAL 211200 Building Maint. Supplies	(180.35)
214100 Land Improvement Maint. Services					
7/12/2022	24376		Carson Landscape Indus. - 18136	HSP Irrigation repair- Rotors	c (870.00)
8/2/2022	24415		Rio Linda Fence - 57446	ACP Welded bolts solar light base on 14 light poles	c (675.00)
9/7/2022	24443		Carson Landscape Indus. - 18136	HSP Irrigation repair- Valve	c (2,900.00)

11/3/2022	24527	Rio Linda Fence - 57446	HSP - Repair fence near soccer field (fire dept damage)	c	(450.00)
12/27/2022	24601	S Dave Weber - 54010	Post Removal @ HSP		(550.00)
			Demolished Concrete Picnic Tables @ HSP		(1,500.00)
			TOTAL 214100 Land Improvement Maint. Services		(6,945.00)
214200 Land Improvement Maint. Supplies					
7/12/2022	24383	Home Depot - 2843	Irrigation Supply	c	(17.68)
7/12/2022	24384	Normac - 1309	Irrigation supplies - 12 Rotors	c	(474.39)
9/26/2022	24476	Home Depot - 2843	ACP - Dog Park Sand	c	(35.36)
			TOTAL 214200 Land Improvement Maint. Supplies		(527.43)
215100 Mechanical Sys Maint. Services					
7/20/2022	24392	Clarke & Rusch - 8939	7/11/2022 Planned Maint.	c	(229.00)
8/15/2022	24425	All Pro Backflow - 69926	Backflow test @ ACP 2	c	(160.00)
8/15/2022	24426	All Pro Backflow - 69926	Backflow test @ Oak 4	c	(320.00)
12/15/2022	24580	Clarke & Rusch - 8939	11/8/2022 Planned Maint.	c	(229.00)
			TOTAL 215100 Mechanical Sys Maint. Services		(938.00)
215200 Mechanical Sys Maint. Supplies					
8/10/2022	24424	S Umpqua CC - 71085	Safety Cabinet (Fuel Storage)	c	(1,151.03)
			TOTAL 215200 Mechanical Sys Maint. Supplies		(1,151.03)
216200 Painting Supplies					
12/2/2022	24561	S Home Depot - 2843	Paint Supplies	c	(176.29)
			2% Prompt pmt discount	c	3.27
			TOTAL 216200 Painting Supplies		(173.02)
216700 Plumbing Maint. Service					
10/13/2022	24499	Clarke & Rusch - 8939	Plumbing Service HSP Public RR (mens)	c	(399.20)
11/22/2022	24551	America's Plumbing - 70141	Plumbing Service HSP Public RR (mens)	c	(279.49)
			TOTAL 216700 Plumbing Maint. Service		(678.69)
219100 Electricity					
7/12/2022	24388	SMUD - 4025	6/2022 - SMUD Billing	c	(1,486.78)
8/10/2022	24423	SMUD - 4025	7/2022 - SMUD Billing	c	(2,352.09)
9/7/2022	24455	SMUD - 4025	8/2022 - SMUD Billing	c	(1,836.85)
10/13/2022	24505	SMUD - 4025	9/2022 - SMUD Billing	c	(1,516.91)
11/14/2022	24542	SMUD - 4025	10/2022 - SMUD Billing	c	(1,277.02)
12/8/2022	24578	SMUD - 4025	11/2022 - SMUD Billing	c	(1,074.16)

				TOTAL 219100 Electricity	(9,543.81)
219200 Natural Gas Service					
7/5/2022	24369	PG&E - 1383	6/2022 - Billing	c	(15.63)
8/2/2022	24411	PG&E - 1383	7/2022 - Billing	c	(16.68)
9/7/2022	24452	PG&E - 1383	8/2022 - Billing	c	(15.64)
10/4/2022	24488	PG&E - 1383	9/2022 - Billing	c	(15.63)
11/3/2022	24525	PG&E - 1383	10/2022 - Billing	c	(18.00)
12/2/2022	24567	PG&E - 1383	11/2022 - Billing	c	(460.99)
			TOTAL 219200 Natural Gas Service		(542.57)
219300 Refuse Collection-Disposal					
7/20/2022	24395	S Republic Services - 57909	6/2022 Billing	c	(342.19)
			CREDIT - Billed in error Organics Waste	c	152.29
8/2/2022	24412	S Republic Services - 57909	7/2022 Billing	c	(289.90)
			CREDIT - Billed in error Organics Waste	c	100.00
9/7/2022	24453	S Republic Services - 57909	8/2022 Billing	c	(289.90)
			7/26/2022 Overage Charge	c	(88.00)
			Deduction Billing error for Organic Waste	c	100.00
11/3/2022	24526	S Republic Services - 57909	Credit from 9/2022 billing	c	2.28
			10/2022 Billing	c	(189.90)
12/8/2022	24576	Republic Services - 57909	11/2022 - Billing	c	(189.90)
			TOTAL 219300 Refuse Collection-Disposal		(1,035.22)
219500 Sewage Services					
8/2/2022	24416	Sacramento County utilities - 666	6/22 -8/21/2022- Billing	c	(276.28)
10/4/2022	24493	Sacramento County utilities - 666	8/22 -10/21/2022- Billing	c	(276.28)
12/8/2022	24577	Sacramento County utilities - 666	10/22 -12/21/2022- Billing	c	(276.28)
			TOTAL 219500 Sewage Services		(828.84)
219800 Water					
7/20/2022	24396	Sacramento Suburban Water - 26158	7/2022 - Garfield (ACP)	c	(1,157.52)
7/26/2022	24403	Sacramento Suburban Water - 26158	7/2022 - Myrtle (Oak)	c	(746.12)
7/26/2022	24404	Sacramento Suburban Water - 26158	7/2022 - HSP	c	(146.19)
8/23/2022	24437	Sacramento Suburban Water - 26158	8/2022 - Garfield (ACP)	c	(1,356.32)
8/23/2022	24438	Sacramento Suburban Water - 26158	8/2022 - Myrtle (Oak)	c	(1,613.74)
8/23/2022	24439	Sacramento Suburban Water - 26158	8/2022 - HSP	c	(149.03)
9/21/2022	24473	Sacramento Suburban Water - 26158	9/2022 - Garfield (ACP)	c	(975.76)
10/4/2022	24494	Sacramento Suburban Water - 26158	9/2022 - Myrtle (Oak)	c	(801.50)

10/4/2022	24495	Sacramento Suburban Water - 26158	9/2022 - HSP	c	(151.87)
10/20/2022	24513	Sacramento Suburban Water - 26158	10/2022 - Garfield (ACP)	c	(852.22)
11/3/2022	24528	Sacramento Suburban Water - 26158	10/2022 - Myrtle (Oak)	c	(763.16)
11/3/2022	24529	Sacramento Suburban Water - 26158	10/2022 - HSP	c	(149.03)
11/21/2022	24550	Sacramento Suburban Water - 26158	11/2022 - Garfield (ACP)	c	(825.24)
12/2/2022	24569	Sacramento Suburban Water - 26158	11/2022 - Myrtls (Oak)	c	(840.90)
12/2/2022	24570	Sacramento Suburban Water - 26158	11/2022 - HSP	c	(169.61)
12/15/2022	24587	Sacramento Suburban Water - 26158	12/2022 - Garfield (ACP)	c	(724.42)
12/20/2022	24595	Sacramento Suburban Water - 26158	12/2022 - Myrtle (Oak)	c	(947.76)
12/20/2022	24596	Sacramento Suburban Water - 26158	12/2022 - HSP		(160.39)
TOTAL 219800 Water					(12,530.78)

220500 Automotive Maint. Service

9/21/2022	24472	S OK Tire - 14277	Labor - 1996 Chevy -Charging System, 2 Mirrors	c	(470.85)
12/2/2022	24565	S OK Tire - 14277	Labor - 2010 Ford	c	(39.90)
TOTAL 220500 Automotive Maint. Service					(510.75)

220600 Automotive Maint. Supplies

9/21/2022	24472	S OK Tire - 14277	Parts - 1996 Chevy - 2 Mirrors	c	(142.12)
12/2/2022	24565	S OK Tire - 14277	Parts - 2010 Ford - Tire Sensor	c	(193.84)
TOTAL 220600 Automotive Maint. Supplies					(335.96)

221100 Grounds Equip Maint. Services

7/12/2022	24385	S PAPE - 18032	Labor - J Deere 2011 Z920	c	(667.20)
7/25/2022	EFT	S Sacramento For Tractors - 64608	Ref Claim 23831 (correcting entry)	c	302.50
9/7/2022	24454	S Sacramento For Tractors - 64608	Labor Repairs - Kubota	c	(1,170.00)
TOTAL 221100 Grounds Equip Maint. Services					(1,534.70)

221200 Ground Equip Maint. Supplies

7/12/2022	24385	S PAPE - 18032	Repair Parts - J Deere 2011 Z920	c	(766.51)
7/12/2022	24386	PAPE - 18032	Parts filters - J Deere 2021 Z997	c	(60.40)
7/25/2022	EFT	S Sacramento For Tractors - 64608	Ref Claim 23831 (correcting entry)	c	294.56
8/10/2022	24422	J&J Locksmith - 1833	HSP - repair locks	c	(218.19)
9/7/2022	24454	S Sacramento For Tractors - 64608	Repair Parts - Kubota	c	(1,419.94)
9/21/2022	24465	S Bar-Hein Co. - 1463	2 Trimmer heads	c	(78.20)
10/24/2022	24515	S J&J Locksmith - 1833	3/Locks, Tri Flow	c	(86.96)
12/2/2022	24560	Home Depot - 2843	2/Circular saw blades	c	(107.73)
TOTAL 221200 Ground Equip Maint. Supplies					(2,443.37)

222600 Hand - Expendable Tools

8/10/2022	24424	S	Umpqua CC - 71085	Maint. Tools	c	(27.83)
9/21/2022	24465	S	Bar-Hein Co. - 1463	30" Loppers / 4 Tarps	c	(85.12)
9/21/2022	24471	S	Home Depot - 2843	Power Saw & Drill, asst tools	c	(321.65)
TOTAL 222600 Hand - Expendable Tools						(434.60)

223600 Fuel & Lubricant Supplies

7/5/2022	24368		Orbit Station - 33714	6/2022- Fuel Chgs	c	(582.87)
7/12/2022	24387		Phillips 66 - 58398	6/2022 - Stmt	c	(39.99)
8/2/2022	24410		Orbit Station - 33714	7/2022- Fuel Chgs	c	(201.61)
8/15/2022	24429		Phillips 66 - 58398	7/2022 - Stmt	c	(258.60)
9/7/2022	24451		Orbit Station - 33714	8/2022- Fuel Chgs	c	(225.92)
9/21/2022	24471	S	Home Depot - 2843	4 Grease Cartridges	c	(19.27)
10/13/2022	24502		Orbit Station - 33714	9/2022- Fuel Chgs	c	(200.00)
11/3/2022	24524		Orbit Station - 33714	10/2022- Fuel Chgs	c	(134.53)
11/14/2022	24541		Phillips 66 - 58398	10/2022 - Stmt	c	(368.20)
12/2/2022	24566		Orbit Station - 33714	11/2022- Fuel Chgs	c	(220.20)
TOTAL 223600 Fuel & Lubricant Supplies						(2,251.19)

226200 Office Equip Maint Supplies

9/7/2022	24447		Encompass - 18796	Toner - Blk	c	(215.49)
9/7/2022	24448		Encompass - 18796	Copier - Replaced Transfer Belt	c	(297.38)
TOTAL 226200 Office Equip Maint Supplies						(512.87)

227504 Misc (Bottled Water for Staff)

9/26/2022	24478	S	Smart & Final - 22935	8 cases water for staff	c	(57.92)
12/15/2022	24590	S	Smart & Final - 22935	4 cases water for staff	c	(28.96)
TOTAL 227504 Misc (Bottled Water for Staff)						(86.88)

231400 Clothing - Personal Supplies

11/3/2022	24523	S	Home Depot - 2843	Staff Safety & Rain Gear	c	(73.68)
12/2/2022	24572	S	Umpqua CC - 71085	Staff shirts	c	(234.57)
TOTAL 231400 Clothing - Personal Supplies						(308.25)

232200 Custodial Supplies

7/12/2022	24380		Cintas - 56036	7/8/2022 Custodial	c	(116.52)
7/25/2022	24398		Cintas - 56036	7/22/2022 Custodial	c	(116.52)
8/10/2022	24419		Cintas - 56036	8/5/2022 Custodial	c	(116.52)
8/23/2022	24434		Cintas - 56036	8/19/2022 Custodial	c	(116.52)

9/7/2022	24445 Cintas - 56036	8/31/2022 Custodial	c	(116.52)
9/21/2022	24469 Cintas - 56036	9/14/2022 Custodial	c	(116.52)
9/26/2022 24478	S Smart & Final - 22935	Custodial cleaners, bleach, Pine Sol, Dawn	c	(33.16)
10/4/2022	24482 Cintas - 56036	9/28/2022 Custodial	c	(116.52)
10/13/2022	24498 Cintas - 56036	10/12/2022 Custodial	c	(116.52)
11/3/2022	24521 Cintas - 56036	10/26/2022 Custodial	c	(116.52)
11/3/2022 24523	S Home Depot - 2843	Custodial items	c	(24.05)
11/14/2022	24534 Cintas - 56036	11/9/2022 Custodial	c	(116.52)
12/2/2022	24556 Cintas - 56036	11/23/2022 Custodial	c	(116.52)
12/8/2022	24575 Cintas - 56036	12/7/2022 Custodial	c	(116.52)
12/15/2022 24590	S Smart & Final - 22935	Skunk Deodorizer Items	c	(6.18)
12/27/2022	24597 Cintas - 56036	12/21/2022 Custodial		(116.52)
		TOTAL 232200 Custodial Supplies		(1,578.15)
244300 Medical Service -EE & Live Scan				
10/20/2022	24509 Carmichael Box Shop - 59986	Live Scan - Bell	c	(25.00)
11/21/2022	24546 Carmichael Box Shop - 59986	Live Scan - Connolly	c	(25.00)
11/21/2022	24549 Preferred Alliance - 34429	Non-Random Test - Pre-placement - Bell, Connolly	c	(86.00)
		TOTAL 244300 Medical Service -EE & Live Scan		(136.00)
244400 Medical Supplies (First Aid)				
11/3/2022 24532	S Umpqua CC - 71085	Replenish first aid supplies	c	(134.03)
12/2/2022 24572	S Umpqua CC - 71085	Replenish first aid supplies	c	(7.14)
		TOTAL 244400 Medical Supplies (First Aid)		(141.17)
250700 Assessment - Collection Services				
8/15/2022	24428 LAFCo - 2263	FY2022-23 - Special District Assessment	c	(109.00)
		TOTAL 250700 Assessment - Collection Services		(109.00)
253100 Legal Services				
7/12/2022	24381 Cole Huber - 54641	6/2022 Ref:ACP Property	c	(157.50)
9/13/2022	24460 Cole Huber - 54641	8/2022 Ref:ACP Property	c	(225.00)
10/13/2022	24500 Cole Huber - 54641	9/2022 Ref:Prep & Attend Brd Mtg/ACP Property	c	(450.00)
11/14/2022	24535 Cole Huber - 54641	10/2022 Ref:ACP Property/Respond Audit letter	c	(488.07)
12/15/2022	24581 Cole Huber - 54641	11/2022 Ref:ACP Property	c	(517.50)
		TOTAL 253100 Legal Services		(1,838.07)
257100 Security Services				
7/26/2022	24402 Fulton-El Camino Rec & Park - 2968	6/2022 - Patrol Service 11/24 Hours	c	(2,275.00)

8/23/2022	24435	Fulton-El Camino Rec & Park - 2968	7/2022 - Patrol Service 31/16 Hours	c	(3,149.00)
9/7/2022	24458	S Umpqua CC - 71085	Trial Cams & Flkashdrive (security Items)	c	(233.78)
10/20/2022	24510	Fulton-El Camino Rec & Park - 2968	8/2022 - Patrol Service 18/-0- Hours Final Billing	c	(1,206.00)
					TOTAL 257100 Security Services
					(6,863.78)

258200 Public Relations Services

7/5/2022	24373	S Streamline - 57252	Streamline Website 1 yr	c	(1,200.00)
					Credit
					100.00
					TOTAL 258200 Public Relations Services
					(1,100.00)

259100 Other Professional Services

8/2/2022	24408	Crime Alert Security - 41852	Alarm System deposit - Alarm Rental Facilities, Cameras	c	(6,740.00)
9/13/2022	24463	Crime Alert Security - 41852	Alarm System Install - Rental Facilities, Cameras	c	(6,740.00)
11/3/2022	24530	SCI Consulting Group - 2365	FY 18-19 Annual & 5 yr Nexus study (related consulting service	c	(1,501.50)
11/14/2022	JV	# 110767206	Re-allocate Claim 24530 from 339A to 339I (Nexus Study)	c	1,501.50
12/27/2022	24600	Crime Alert Security - 41852	Upgrade Shop to LE4000E Universal Communicator		(260.00)
					TOTAL 259100 Other Professional Services
					(13,740.00)

281265 Application Software Maint. Lic

8/2/2022	24409	Fast Break - 37998	1 Yr Renewal - Microsoft Office 365	c	(99.99)
9/7/2022	24444	S Central Control System - 23278	7/2022 Wireless Irrigation	c	(220.00)
					8/2022 Wireless Irrigation
					(220.00)
					9/2022 Wireless Irrigation
					(220.00)
11/3/2022	24520	Central Control System - 23278	11/2022 - Wireless irrigation	c	(220.00)
11/14/2022	24533	Central Control System - 23278	10/2022 - Wireless irrigation (rec'd inv 11/14/2022)	c	(220.00)
12/2/2022	24555	Central Control System - 23278	12/2022 - Wireless irrigation	c	(220.00)
					TOTAL 281265 Application Software Maint. Lic
					(1,419.99)

281700 Election Services

12/27/2022	24598	County Of Sacramento - Voter Registration - 14	2022 Election Cost	c	(1,887.00)
					TOTAL 281700 Election Services
					(1,887.00)

283102 Mileage

7/20/2022	24394	Kim Cook - 919996	7/2022 - Mileage Reimb	c	(22.15)
8/15/2022	24427	Kim Cook - 919996	8/2022 - Mileage Reimb	c	(14.54)
9/7/2022	24449	Kim Cook - 919996	8/2022 - Mileage Reimb	c	(12.29)
9/7/2022	24450	Lisa Gonzalez - 932917	8/2022 - Mileage Reimb	c	(18.84)
10/4/2022	24485	Kim Cook - 919996	9/2022 - Mileage Reimb	c	(12.79)
10/4/2022	24486	Lisa Gonzalez - 932917	9/2022 - Mileage Reimb	c	(16.15)

10/24/2022	24516	Kim Cook - 919996	10/2022 - Mileage Reimb	c	(12.79)
11/14/2022	24540	Lisa Gonzalez - 932917	11/14/2022 - Mileage	c	(8.75)
12/2/2022	24562	Kim Cook - 919996	Adjusted mileage rate on prior reimbursements	c	(4.96)
12/2/2022	24563	Kim Cook - 919996	11/2022 Mileage reimb	c	(13.88)
12/2/2022	24564	Lisa Gonzalez - 932917	Adjusted mileage rate on prior reimbursements	c	(2.39)
			TOTAL 283102 Mileage		(139.53)
285200 Recreation Supplies					
10/4/2022	24484	Home Depot - 2843	9/30/2022- Magic Show items	c	(10.75)
10/4/2022	24487	Lisa Gonzalez - 932917	Reimb- 9/30/2022 Magic Show items	c	(40.09)
10/20/2022	24512	Park Planet - 29271	HSP Replacement Inclusive Swing Seat	c	(1,679.25)
11/3/2022	24532	S Umpqua CC - 71085	Supplies for Magic Show on 9/30/2022	c	(14.81)
			TOTAL 285200 Recreation Supplies		(1,744.90)
289800 Other Operating Exp - Supplies					
8/10/2022	24424	S Umpqua CC - 71085	Official Document ref: ACP Property	c	(33.50)
8/15/2022	JV	# 110691470	Re-allocate to 339D 420200 from 339A 289800 (Prop 68 Proje	c	33.50
9/7/2022	24458	S Umpqua CC - 71085	Prop 68 Sign, Notary for Documents	c	(212.83)
9/13/2022	JV	# 110714399	Re-allocate to 339D 420200 from 339A 289800 (Prop 68 Proje	c	212.83
10/4/2022	24497	Umpqua CC - 71085	9/2022 Stmt	c	(203.50)
10/20/2022	JV	# 110746256	Re-allocate to 339D 420200 from 339A 289800 (Prop 68 Proje	c	203.50
11/21/2022	24548	S Pet Waste Eliminator - 69321	Pet waste bags	c	(233.87)
			Tax Accrual S/H	c	(2.09)
			TOTAL 289800 Other Operating Exp - Supplies		(235.96)
289900 Other Oper Exp Fire Extingusher					
11/21/2022	24547	Jorgenson Co - 48104	2022 Yrly Fire Exten. Inspection @ HSP	c	(183.87)
			TOTAL 289900 Other Oper Exp Fire Extingusher		(183.87)
291300 Auditor Controller Services					
12/15/2022	24586	Larry Bain, CPA - 26727	FY 21/22 - Audit	c	(6,500.00)
			TOTAL 291300 Auditor Controller Services		(6,500.00)
291500 Compass Costs					
8/9/2022	EFT	S Compass License Fee	FY 22/23 -Compass VPN Connection	c	(372.00)
			FY 22/23 - Compass License Fee	c	(699.83)
			TOTAL 291500 Compass Costs		(1,071.83)
291700 Alarm Services					

7/5/2022	24363	Crime Alert Security - 41852	7/2022 -9/30/2022- Alarm System - Office & Shop	c	(210.00)
7/5/2022	24371	Sacramento Control Systems - 1112	7/2022 -9/30/2022 -AES Fire Monitoring	c	(241.63)
9/7/2022	24446	S Crime Alert Security - 41852	7 Days New System Blding Alarm & Cameras	c	(51.33)
			9/1 - 11/30/2022 Alarm System - Bldings	c	(135.00)
			9/1 - 11/30/2022 - Alarm System Cameras	c	(525.00)
9/13/2022	24462	Crime Alert Security - 41852	10/2022 -12/31/2022- Alarm System - Office & Shop	c	(210.00)
10/4/2022	24490	Sacramento Control Systems - 1112	10/2022 -12/31/2022 -AES Fire Monitoring	c	(241.63)
11/14/2022	24537	S Crime Alert Security - 41852	12/1 - 2/28/2022 - Alarm system Bldings	c	(135.00)
			12/1 - 2/28/2022 - Alarm System Cameras	c	(525.00)
12/15/2022	24583	Crime Alert Security - 41852	1/2023 - 3/31/2022 Alarm System Office & Shop	c	(210.00)
12/27/2022	24599	Crime Alert Security - 41852	A/o 1/2023 - 3/31/2022 Alarm System Shop		(30.00)
TOTAL 291700 Alarm Services					(2,514.59)

298700 Telephone Services

7/5/2022	24365	Fast Break - 37998	6/2022 Phone service	c	(195.00)
7/12/2022	24382	Comcast - 12322	7/2022-Billing-Phone/HSI (w/late fee)	c	(116.59)
8/10/2022	24420	Comcast - 12322	8/2022-Billing-Phone/HSI	c	(106.61)
8/10/2022	24421	Fast Break - 37998	7/2022 Phone service	c	(195.00)
9/13/2022	24461	Comcast - 12322	9/2022-Billing-Phone/HSI	c	(106.61)
9/13/2022	24464	Fast Break - 37998	8/2022 Phone service	c	(195.00)
10/4/2022	24483	Fast Break - 37998	9/2022 Phone service	c	(195.00)
10/13/2022	24501	Comcast - 12322	10/2022-Billing-Phone/HSI	c	(106.41)
11/3/2022	24522	Fast Break - 37998	10/2022 Phone service	c	(195.00)
11/14/2022	24536	Comcast - 12322	11/2022-Billing-Phone/HSI	c	(106.41)
12/2/2022	24558	Fast Break - 37998	11/2022 Phone service	c	(195.00)
12/15/2022	24582	Comcast - 12322	12/2022-Billing-Phone/HSI	c	(106.41)
TOTAL 298700 Telephone Services					(1,819.04)

298701 Cell Phones

7/5/2022	24366	Fast Break - 37998	1 year - email exchange + Board Mbrs	c	(660.00)
8/2/2022	24417	S T-Mobile - 32685	7/2022 - District Cell Phone	c	(29.42)
			GM phone (purchase pmt)	c	(33.34)
9/7/2022	24457	S T-Mobile - 32685	8/2022 - District Cell Phone	c	(29.42)
			GM phone (purchase pmt)	c	(33.34)
10/4/2022	24496	S T-Mobile - 32685	9/2022 - District Cell Phone	c	(29.42)
			GM phone (purchase pmt)	c	(33.34)
11/3/2022	24531	S T-Mobile - 32685	10/2022 - District Cell Phone	c	(29.41)
			GM phone (purchase pmt)	c	(33.34)
12/2/2022	24571	S T-Mobile - 32685	11/2022 - District Cell Phone	c	(29.41)

				GM phone (purchase pmt)	c	(33.34)
				TOTAL 298701 Cell Phones		(973.78)
299909	Expenditure Reimb. (Ins Claims)					
7/5/2022	24372	Staples Construction - 52639		HSP Vandalism 3/2022 - Public RR	c	(4,791.28)
8/15/2022	24430	Staples Construction - 52639		HSP Vandalism 3/2022 - Public RR	c	(15,154.49)
				TOTAL 299909 Expenditure Reimb. (Ins Claims)		(19,945.77)
321000	Interest Expense					
7/5/2022	24374	S	Umpqua Bank - 52152	7/2022 - Side Fund Interest	c	(648.50)
7/25/2022	24401	S	Umpqua Bank - 52152	8/2022 - Side Fund Interest	c	(639.57)
8/23/2022	24440	S	Umpqua Bank - 52152	9/2022 - Side Fund Interest	c	(630.63)
9/26/2022	24479	S	Umpqua Bank - 52152	10/2022 - Side Fund Interest	c	(621.69)
10/24/2022	24517	S	Umpqua Bank - 52152	11/2022 - Side Fund Interest	c	(612.76)
11/22/2022	24552	S	Umpqua Bank - 52152	12/2022 - Side Fund Interest	c	(603.81)
12/27/2022	24602	S	Umpqua Bank - 52152	1/2023 - Side Fund Interest	c	(594.88)
				TOTAL 321000 Interest Expense		(4,351.84)
323000	Lease Oblig Retirement Side Fund					
7/5/2022	24374	S	Umpqua Bank - 52152	7/2022 - Side Fund Principal	c	(2,500.00)
7/25/2022	24401	S	Umpqua Bank - 52152	8/2022 - Side Fund Principal	c	(2,500.00)
8/23/2022	24440	S	Umpqua Bank - 52152	9/2022 - Side Fund Principal	c	(2,500.00)
9/26/2022	24479	S	Umpqua Bank - 52152	10/2022 - Side Fund Principal	c	(2,500.00)
10/24/2022	24517	S	Umpqua Bank - 52152	11/2022 - Side Fund Principal	c	(2,500.00)
11/22/2022	24552	S	Umpqua Bank - 52152	12/2022 - Side Fund Principal	c	(2,500.00)
12/27/2022	24602	S	Umpqua Bank - 52152	1/2023 - Side Fund Principal	c	(2,500.00)
				TOTAL 323000 Lease Oblig Retirement Side Fund		(17,500.00)
345000	Taxes, Licenses & Assessments					
10/4/2022	24491	Sacramento County - Tax Collectors Office - 472{HSP - CSA1 Lights			c	(655.74)
10/4/2022	24492	Sacramento County - Tax Collectors Office - 472{ACP - CSA1 Lights			c	(47.90)
				TOTAL 345000 Taxes, Licenses & Assessments		(703.64)
				TOTAL EXPENSES		(218,765.89)
				OVERALL TOTAL		(218,765.89)

**ACRPD 2022-2023
339D Expenditures**

**December 2022
Period 6 of 13**

FYTD Completed = 46%

	CODE	CAPITAL OUTLAY	2022-23 Budget	December	Expended To Date	Balance	Percent Expended
1	20227504	Miscellaneous	31,410.00		-	31,410.00	0%
2							
3							
4							
5	42420100	Buildings New ADA Features @ HSP			-	-	#DIV/0!
6	42420110	Leasehold Improv. (Oakdale Park)			-	-	#DIV/0!
7	42420200	Structures ACP Park Improv. Proj			-	-	#DIV/0!
8	"	ACP Restroom Building	175,044.00		146,628.00	28,416.00	84%
9	"	ACP Parking Lot Repaving			-	-	#DIV/0!
10	"	ACP Improvements (Prop 68)	147,427.00		19,020.39	128,406.61	13%
11	43430300	Equipment-SD Non-Recon - New Play Equip			-	-	#DIV/0!
12	45450300	Infr--SD-Non-Recon - ACP Pedi Bridge Proj			-	-	#DIV/0!
13	46460300	Other Intangible Asset-Spec Dist - HSP Comm. Ctr Impro.			-	-	#DIV/0!
14	46461300	Intangibles - ???			-	-	
15					-	-	-0-
16		TOTALS:	353,881.00	\$ -	\$ 165,648.39	\$ 188,232.61	47%

Funds placed in 20227504 - Miscellenous were placed in this GL Line item for the sole purpose of returning to the 339I Impact Fees account

ACRPD 2022-2023
339D Revenue

December 2022
Period 6 of 13

FYTD Completed = 46%

	Account	2022-23 Budget	December	Received To Date	Unrealized	Percent Received
1	94941000 Interest Income			-	-	#DIV/0!
				-	-	#DIV/0!
2	95952900 In Lieu Fees Transfer			-	-	#DIV/0!
				-	-	#DIV/0!
3	95956300 State-Federal Grants(Jo Smith PEDI Bridge Proj)			-	-	#DIV/0!
4	" State-Federal Grants (Dist Proj/Per Capita Funds)	147,427.00		-	147,427.00	0%
5	"			-	-	#DIV/0!
6	"			-	-	#DIV/0!
				-	-	#DIV/0!
7	95956900 Other Funds - Local (339I Funds)			-	-	#DIV/0!
8	" *Jo Smith PEDI Bridge Proj			-	-	#DIV/0!
9	" *ACP-Park Improvements	175,044.00		175,044.00	-	100%
10	" *HSP Community Ctr Improvements			-	-	#DIV/0!
11	" *HSP ADA Improvements			-	-	#DIV/0!
12				-	-	#DIV/0!
13	95956910 State Match UMPQUA Bank Line of Credit			-	-	#DIV/0!
14	" *Jo Smith PEDI Bridge Proj			-	-	#DIV/0!
15				-	-	#DIV/0!
16				-	-	#DIV/0!
17				-	-	#DIV/0!
18	5506614 Investment Earns			-	-	#DIV/0!
19	Total Other Revenue	\$ 322,471.00	\$ -	\$ 175,044.00	\$ 147,427.00	54%
20	Beginning Fund Balance Available \$XXXXX			-	\$ -	0%
21	Fund Balance Decreased by				\$ -	
22	TOTALS:	322,471.00	-	175,044.00	147,427.00	

Note: Per Resolution 2022-22 via JV 110777002, Short term loan of \$147,427.55 provided to 339D GL 5250000 by 339A GL 1800000

Register Expense Report
Period 6
Account

FY 2022 - 2023
12/1/2022 Through 12/31/2022
339D Project Account

Not
Clrd

Date	Num	Description	Account	Memo	Category	Clrd	Amount

Date Num

Description

Memo

Clr

Amount

INCOME

956900 Other Funds - Local (GRANTS)

10/4/2022 JV	# 110738172	Transferred from 339I to 339D ACP Restroom Project	c	175,044.00
TOTAL 956900 Other Funds - Local (GRANTS)				175,044.00

TOTAL INCOME 175,044.00

EXPENSES

420200 Structures (Projects @ ACP)

7/5/2022	211 Public Restroom Company - 429070	ACP RR Project (339I Funds)	c	(57,235.00)
8/2/2022	212 Staples Construction - 52639	ACP RR Project (Prop 68 Funding)	c	(18,570.56)
8/15/2022 JV	# 110691470	e-allocate from 339A 289800 to 339D 420200 (Prop 68 Project)	c	(33.50)
9/7/2022	213 Public Restroom Company - 429070	ACP RR Project (339I Funds)	c	(47,043.00)
9/13/2022 JV	# 110714399	e-allocate to 339D 420200 from 339A 289800 (Prop 68 Project)	c	(212.83)
9/26/2022	214 Public Restroom Company - 429070	ACP RR Project (339I Funds)	c	(42,350.00)
10/20/2022 JV	# 110746256	e-allocate to 339D 420200 from 339A 289800 (Prop 68 Project)	c	(203.50)
TOTAL 420200 Structures (Projects @ ACP)				(165,648.39)

TOTAL EXPENSES (165,648.39)

OVERALL TOTAL 9,395.61

**Arcade Creek Recreation and Park District
2022 - 2023 Monthly Revenue Reports**

December 2022

Period 6

339B - Grant Trust

<u>Beginning Balance</u>	<u>Debits</u>	<u>Credits</u>	<u>Ending Balance</u>
\$ -	\$ -	\$ -	\$ -

088H - Park Dedication

<u>Beginning Balance</u>	<u>Debits</u>	<u>Credits</u>	<u>Ending Balance</u>
\$ 6,534.66	\$ -	\$ 40.00	\$ 6,574.66

339C - ADA Funds

<u>Beginning Balance</u>	<u>Debits</u>	<u>Credits</u>	<u>Ending Balance</u>
\$ 1,378.59	\$ -	\$ -	\$ 1,378.59

339I - Park Impact Fee's

<u>Beginning Balance</u>	<u>Debits</u>	<u>Credits</u>	<u>Ending Balance</u>
\$ 287,819.99	\$ -	\$ 7,322.00	\$ 295,141.99

10/4/2022 Transferred \$175,044.00 to 339D ACP Restroom Blding Project

11/14/2022 Transferred \$1,501.50 charge from 339A to cover cost of Admin Fee 5yr annual & FY 18-19 Annual

Arcade Creek Recreation Park District Monthly Payroll Report

Start of Pay Period	December 1, 2022	December 16, 2022
End of Pay Period	December 15, 2022	December 13, 2022
Payroll Issued:	December 31, 2022	January 15, 2023

Administration Division	6351.32	6351.32	12,702.64
Board Members = 5	250.00		250.00
Parks Division	2217.61	2240.70	4,458.31
PT Maint	<u>0</u>		-
Recreation Division			
Monitors, etc	724.50	504.00	1,228.50
Misc - Staff	0.00	0.00	-
Rec. Staff (Other)	<u>0.00</u>	<u>0.00</u>	-
\$	9,543.43	\$ 9,096.02	\$ 18,639.45
Employer Paid Taxes <i>(FICA, Medicare, SUJ)</i>	730.07	Unavailable	

Rental & Misc. Revenue Report

December 2022

94942900 - SOCIAL/EVENT BUILDING / GPA / SPORT FIELD RENTALS

Rental Date	Renter	Location	Amount
	SACC (Creek Mtg's)	Sm Rm	-0-

Total Rentals \$ - **A**

94942900 - LONG TERM STUDIO/ FIELD SPACE RENTAL

Rental Date(s)	Renter	Location	Amount

Totals \$ - **B**

94942900 - CELL TOWER REVENUE

Dec-22	Site ID 810224 HSP- 810224 = 2,260.42 and 810213 ACP-810213 = \$2,350.00	4,610.42
--------	---	----------

Totals \$ 4,610.42 **C**

97979000 - MISC. OTHER REVENUES

Totals \$ - **D**

\$ - A
\$ - B
\$ 4,610.42 C
\$ - D
\$ 4,610.42 Total

Funds Collected and Some Previously Deposited But Attributed to Month Of Report

Arcade Creek Recreation and Park District

MEETING DATE: January 19, 2023

**AGENDA ITEM: 5 g Consent Agenda
Correspondence Period 7**

No correspondence received.

Arcade Creek

Recreation and Park District

January 19, 2023

Board of Directors

Travis Dworetzky
Amanda Gualderama
Michael Hanson
Chris Juell
Alex Vassar

Dear Board of Directors,

Staff has been diligently working on accomplishing tasks on our to do list from the Board Retreat. You will see that on the Board Packet under Tasks completed.

Mailing Address

P.O. Box 418114
Sacramento, CA 95841

Telephone

(916) 482-8377

Email

acrpd@acrpd.com

We will be presenting a contract to the Board of Directors from the Sacramento Area Sewer District about the pipe re-construction at Arcade Creek Park. I am getting a bid to renovate the basketball court at Arcade Creek Park by the January 19th meeting. I am also requesting a bid for Hamilton Street Park basketball court. I will have those 2 bids for the Board at the January 19th meeting. If approved, we could start renovation on the basketball court at Hamilton Street Park in Spring 2023. The Sacramento Area Sewer District will not start their project until 2024 and we will not renovate it until Sac Sewer leaves our park as they will be removing a corner of the basketball court.

Arcade Creek Park

5613 Omni Drive
Sacramento, CA

Hamilton Street Park

4855 Hamilton Street
Sacramento, CA

Oakdale Park

3708 Myrtle Avenue
North Highlands, CA

Still in the waiting game on permits to get started to perform the pre-construction for the Public Restroom Company at Arcade Creek Park.

The building is already manufactured just waiting for permit approval from Sacramento County. Board President, Alex Vassar sent an email to Supervisor Desmond to see if he could give us clarification on why we have not received our permits in 5 months.

Prop 68 Per Capita Grant is completed on my side. Still waiting to get payment processed by the State Per Capita Grant. Due to staff shortage and computer issues, it is taking 3 or more weeks to hear back from the Grant Project Manager. I keep pushing it by emailing 1-2 times per week.

When the last storm arrived, we lost more trees and Raul's tree service came over to Hamilton Street Park and took care of it in one day. Anita was fighting lowering the bridge twice over the weekend. After the storm Anita and Karina picked up several loads of debris from the creek.

The weather has really been a challenge for our Park Maintenance staff but they are dedicated and get through it.

Happy New Year,

Lisa Gonzalez

Meeting Date January 19, 2023		Item # 6 a
		Old Business
Subject: Review and discuss the districts workflow worksheets for Hamilton Street Park and Arcade Creek Park		
Initiated or requested by <input checked="" type="checkbox"/> Board <input type="checkbox"/> Staff <input type="checkbox"/> Other	Item Type <input checked="" type="checkbox"/> Informational <input checked="" type="checkbox"/> Direction <input type="checkbox"/> Action	Report coordinated or prepared by <p style="text-align: center;">Kim Cook</p>
<p>Objective To review and discuss multiple aspects of each park within the district’s oversight and control.</p> <p>Background Over the course of time, deferred maintenance items, amenities, and amenity upgrades, along with many projects have been either ignored or unattainable due to cashflow.</p> <p>The current board of directors requested that staff prepare an extensive detailed spreadsheet that provides information that can be reviewed and discussed, with the desire to set priorities and provide guidance to staff to become proactive rather than reactive in all aspects of the oversight of the properties that the district maintains.</p> <p>Budget/Cost Information Depending on the specific scope of work will determine the cost for overcoming the deferred maintenance items and projects chosen to tackle.</p> <p>Proposed Action To review the spreadsheet information on a regular basis and decide what items or projects that may be achievable during each fiscal year.</p> <p>Alternative Actions Continue to disregard the deferred maintenance items and provide limited changes to the look of the parks and the provided amenities or upgrades.</p>		
Coordination and Review This is a standard practice of the Board.		Attachment(s) District Workflow Worksheets Locations: Hamilton Street Park (HSP) & Arcade Creek Park (ACP)

Line #	Park Location: HSP Small Rental	QTY	Year placed in Service / Changed	Past Current Future	A = Amenity E = Equipment F = Fixture	Last Inspected	Condition S = Satisfactory M = Maint./Repair	Recommendation: Fix/Repair Improve Replace	Date Recommendation Performed	ADA Compliant Yes No NA	Year ADA Compliant	Work to be done by: Employees, Contractor, Volunteers	Preliminary Estimate Cost Range	Time Frame of Work	Recommended Start Date	Priority	What to be done / Comments
	Water Heater (btwn RR's upper area)																

Arcade Creek Recreation and Park District

Meeting Date January 19, 2023		Item # 6 b
		Old Business
Subject: Nominate and vote for Board Officers Positions for 2023		
Initiated or requested by <input type="checkbox"/> Board <input checked="" type="checkbox"/> Staff <input type="checkbox"/> Other	Item Type <input checked="" type="checkbox"/> Informational <input type="checkbox"/> Direction <input checked="" type="checkbox"/> Action	Report coordinated or prepared by <i>Kim Cook</i> Office Manager
Objective To receive interest from Board members for desired positions.		
Background Typically, the Board elects a Chair, Vice-Chair and Secretary/Treasurer during the first Board meeting of each year.		
Analysis The Board Policy stipulates those officers shall be nominated and elected during the first Board meeting of each year.		
Budget/Cost Information None		
Proposed Action To consider leadership positions with the District		
Alternative Actions Maintain the status quo and vote by acclamation.		
Coordination and Review This is a standard practice of the Board.		Attachment(s)

Arcade Creek Recreation and Park District

Meeting Date January 19, 2023		Item # 6 c Old Business
Subject: Discussion regarding lease with Oakdale gym and community center		
Initiated or requested by <input checked="" type="checkbox"/> Board <input checked="" type="checkbox"/> Staff <input type="checkbox"/> Other	Item Type <input checked="" type="checkbox"/> Informational <input checked="" type="checkbox"/> Direction	Report coordinated or prepared by <i>Lisa Gonzalez</i> and Kim Cook
<p><i>Item originally appeared on the December 15, 2022 agenda.</i></p> <p>Objective To pursue a way to leave our current contract with Twin Oaks School District.</p> <p>Background ACRPD entered a 30-year contract Lease Agreement between Rio Linda Union School District (currently known as Twin Rivers Unified School District) and Arcade Creek Recreation and Park District, the current lease term began in April 12,2004 and endures through April 11, 2034.</p> <p>Budget/Cost Information Legal fees from Derek Cole who is spearheading this transaction.</p> <p>Proposed Action Discussion on December 15th Board meeting and add this agenda item to January 19th board meeting with report from Derek Cole and more discussion.</p>		
Coordination and Review This is a standard practice of the Board.		Attachment(s)

Arcade Creek Recreation and Park District

Meeting Date January 19, 2023		Item # 6 d
		Old Business
Subject: Approval of Amendment to General Manager Employment Agreement Authorizing 80 Hours of Administrative Leave.		
Initiated or requested by	Item Type	Report coordinated or prepared by
<input checked="" type="checkbox"/> Board <input type="checkbox"/> Staff <input type="checkbox"/> Other	<input type="checkbox"/> Informational <input type="checkbox"/> Direction <input checked="" type="checkbox"/> Action	 <i>Kim Cook</i> Office Manager
<p>Objective To approve the amendment to the General Managers employment contract with regards to increasing administrative leave.</p> <p>Background During closed session at the Board of Directors meeting held on December 15, 2022, the Directors advised the districts legal counsel to amend the original employment agreement signed on June 25, 2021.</p> <p>Budget/Cost Information None</p> <p>Proposed Action To vote for the attached amended contract.</p> <p>Alternative Actions Not vote for the amended contract and retain the original contract as previously agreed upon on June 25, 2021.</p>		
Coordination and Review		Attachment(s)
This is a standard practice of the Board.		Amended employment contract

**AMENDMENT TO EMPLOYMENT AGREEMENT
BETWEEN THE ARCADE CREEK RECREATION AND PARK DISTRICT
AND GENERAL MANAGER LISA GONZALEZ**

This Amendment to the Employment Agreement between the Arcade Creek Recreation and Park District and Lisa Gonzalez (“General Manager”), dated June 25, 2021 (“Employment Agreement”), is effective on January 3, 2023. The Employment Agreement shall be amended as set forth below. All other terms of the Employment Agreement not amended shall remain the same as set forth in the Employment Agreement.

1. Section 3.B of the Employment Agreement is amended to provide that, in addition to the benefits General Manager receives under that Paragraph, General Manager shall annually receive eighty (80) hours of administrative leave. The full amount of such annual leave shall become available on the first business day of each calendar year. Unused administrative leave shall not carry over into the next calendar year nor shall unused leave be eligible to be paid to General Manager (“cashed out”) at any time or for any reason.

Executed on this _____ day of January, 2023.

Alex Vassar
Chair, Board of Directors
Arcade Creek Recreation and Park District

Lisa Gonzalez
General Manager

Approved as to Form:

Derek P. Cole
General Counsel

Meeting Date January 19, 2023		Item # 6e
Subject: Bringing back the Sacramento Area Sewer District contract after re-negotiation for signature.		
Initiated or requested by <input checked="" type="checkbox"/> Board <input checked="" type="checkbox"/> Staff <input type="checkbox"/> Other	Item Type <input type="checkbox"/> Informational <input type="checkbox"/> Direction <input type="checkbox"/> Action	Report coordinated or prepared by <i>Lisa Gonzalez</i> Lisa Gonzalez, General Manager
Objective To get the revised contract from Sacramento Area Sewer District approved for the General Manager to sign on behalf of the Board of Directors.		
Background Sacramento Area Sewer District performs routine inspection of sewer pipes crossing water ways on an Annual basis to proactively ensure the crossings are not at risk of structural failure. Those crossings deemed to need rehabilitation or replacement have been included in this creek crossing. There are 12 sites located throughout the unincorporated area of Carmichael, Fair Oaks, and the city of Citrus Heights, CA. At this time Sac Area Sewer District desires to acquire a sewer easement, and a temporary construction easement over portions of ACRPD property located at Arcade Creek Park; 5613 Omni Drive, Sacramento, CA 95841		
Budget/Cost Information After negotiations took place with the Sewer District and the General Manager the SASD agreed to pay ACRPD \$40, 920.		
Proposed Action Board Approval to accept \$40, 920 for ACRPD.		
Coordination and Review This is a standard practice of the Board.	Attachment(s) Sacramento Area Sewer contract	

RED File No.: 22-12-003
OWNER: Arcade Creek RPD
APN: 230-0080-037 & 230-0092-037 (Portions)
Project: Creek Crossings (SacSewer)

AGREEMENT FOR PURCHASE OF REAL PROPERTY

This Agreement for Purchase of Real Property, (hereinafter referred to as "Agreement"), is between SACRAMENTO AREA SEWER DISTRICT, a county sanitation district formed pursuant to and operating under the authority of the County Sanitation District Act, commencing at Health and Safety Code section 4700, (hereinafter referred to as "SacSewer"), and Arcade Creek Recreation & Park District, a political subdivision of the State of California, formerly known as Del Paso Recreation and Park District (hereinafter referred to as "Owner").

The parties hereby agree as follows:

1. PROPERTY.

Owner agrees to sell to SacSewer and SacSewer agrees to purchase from Owner pursuant to the terms and conditions set forth in this Agreement, an Easement for Sewer over approximately 23,012 square feet (hereinafter referred to as "Easement") and a Temporary Construction Easement over approximately 3,330 square feet (hereinafter referred to as "TCE"). Sewer Easement is attached hereto as Attachment 1 and includes legal description and plat as Exhibits "A" and "B". The TCE is attached hereto as Attachment 2 and includes plat as Exhibit "B". Owner affirms that it legally owns the property rights to be conveyed by the Easement and the TCE and is empowered to execute said conveyance documents and this Agreement. It is understood that said property rights are necessary for the construction of the Creek Crossings Project (hereinafter referred to as "Project").

2. ESCROW.

This transaction shall be handled through Escrow Number 01006739-010-AM-PJ, (hereinafter referred to as "Escrow"), with Fidelity National Title Company, (hereinafter known as "Escrow Agent"), at 8525 Madison Avenue, Suite 110, Fair Oaks, CA 95628 as described in the attached Escrow Instructions, (hereinafter referred to as "Escrow Instructions"), identified as Attachment 3.

3. DELIVERY OF DOCUMENT/ESCROW.

The conveyance documents for the property rights will be executed in a form supplied by SacSewer and delivered by Owner to SacSewer for the purpose of placing the documents, excepting the TCE, into Escrow. SacSewer shall not be

deemed to have accepted delivery of the Easement and the TCE until such time as the Easement is recorded in the Official Records of the SacSewer of Sacramento, California. SacSewer shall pay all costs of escrow and recording fees incurred in this transaction. The TCE shall not be recorded.

4. PURCHASE PRICE AND ESCROW.

SacSewer shall place into Escrow the sum of \$40,920.00, (hereinafter referred to as "Purchase Price"), for the Easement and the TCE, which the parties agree includes all improvements, damages, and severance. The escrow agent shall deliver the Purchase Price to Owner when title to the Easement vests in the SacSewer free and clear of all liens, encumbrances, assessments, easements, and leases (recorded and/or unrecorded), and taxes as indicated on the Escrow Instructions.

5. PAYMENT OF MORTGAGE OR DEED OF TRUST.

Upon demand by any mortgagee under a mortgage or beneficiary under a deed of trust or lien holder with a lien recorded against the Owner's property, made in writing to SacSewer prior to the close of Escrow, SacSewer may make payable to the mortgagee, beneficiary or lien holder entitled thereunder, an amount not to exceed the Purchase Price under this Agreement. If this section is made applicable by the demand above described then the mortgagee or beneficiary shall, at the close of Escrow, furnish the Owner with good and sufficient receipt showing the monies credited against the indebtedness secured by said mortgage or deed of trust.

6. POSSESSION.

Owner agrees that SacSewer and its authorized agents or contractors may enter upon the Owner's land described herein for purposes of performing activities related to and incidental to the construction of the Project, inclusive of the right to remove and dispose of any improvements, prior to the Owner receiving the Purchase Price. Such possession and use of the land by the SacSewer may commence after full execution of this Agreement and Escrow being fully funded by SacSewer.

Notwithstanding the above, SacSewer's right to possession of the TCE area will be during the term defined in the TCE deed.

7. OWNER'S INDEMNIFICATION.

Owner covenants and agrees to indemnify and hold the SacSewer harmless from any and all claims that third parties may make or assert with respect to the title to the premises and any improvements.

8. RESTORATION OF TEMPORARY CONSTRUCTION EASEMENT.

Upon completion of the Project, SacSewer shall restore, replace or cause to be replaced said TCE area to a condition reasonably similar or like that condition which existed on the date of this Agreement. SacSewer agrees to coordinate its construction activities in a way that minimizes interference with Owner's use of its

property.

9. RE-CONSTRUCTION OF OWNER'S REMAINDER PROPERTY.

SacSewer and its authorized agents and contractors are hereby granted permission to enter onto Owner's remainder property to reconstruct Owner's driveways, walkways, and appurtenant areas as necessary to conform to Project improvements. The cost of such re-construction of the Owner's remainder property shall be borne by SacSewer. Owner is responsible for the reconstruction of all landscape areas, including re-grading and replanting any affected lawn and landscaped areas and repair and/or replacement of irrigation systems for which Owner has been compensated.

10. LEASE WARRANTY.

Owner warrants there are no oral or written leases on any portion of the Property exceeding a period of one month.

11. COUNTY'S USE AND LIABILITY.

SacSewer agrees to release Owner from any liability arising from the SacSewer exercising its rights under this Agreement. Furthermore, SacSewer agrees to assume responsibility for any damages to Owner's property, other than the above mentioned landscaped areas, caused by reason of the SacSewer's use of the Easement and TCE under this Agreement and will, at SacSewer's option, either repair or pay for such damage.

12. GOVERNING LAW/SEVERABILITY.

This Agreement shall be governed by and construed in accordance with the laws of the State of California. If any provision in this Agreement is held by a court of competent jurisdiction to be invalid, void or unenforceable, the remaining provisions shall continue in full force without being impaired.

13. PUBLIC PURPOSE.

Both Owner and SacSewer agree that SacSewer requires the Easement and TCE, which is/are not now appropriated to a public use, for the Project and SacSewer can acquire the Property through the exercise of the power of eminent domain.

Both Owner and SacSewer recognize the expense, time, effort and risk to both Owner and SacSewer in failing to resolve a dispute over compensation for the Easement and TCE by eminent domain litigation; and therefore the parties agree that the compensation set forth herein is in compromise and settlement in lieu of such litigation.

14. AUTHORITY AND EXECUTION.

This Agreement, which is valid only when executed by SacSewer, constitutes the complete understanding and Agreement of the parties hereto and no oral

representation shall in any manner vary the terms hereof or be binding.

15. ENTIRE AGREEMENT.

The performance of this Agreement constitutes the entire consideration for the conveyances from Owner and shall relieve the SacSewer of all further obligation or claim on this account, or on account of the location, grade or construction of the proposed public improvement and related facilities and/or structures. The obligations of the parties hereto shall survive the close of escrow.

16. COUNTERPARTS

Agreement may be executed in several counterparts, and shall be deemed one and the same agreement. Electronic and scanned signatures shall be deemed original signatures for all purposes, including proof of terms herein, and shall be binding on each party.

(The Remainder of this page is intentionally left blank.)

This Agreement shall bind the respective heirs, personal representatives, successors, and assigns of the parties hereto.

IN WITNESS WHEREOF, the parties have executed this Agreement as follows:

SacSewer

OWNER

Sacramento Area Sewer District, a county sanitation district formed pursuant to and operating under the authority of the County Sanitation District Act, commencing at Health and Safety Code section 4700

Arcade Creek Recreation & Park District, a political subdivision of the State of California, formerly known as Del Paso Recreation and Park District

Date: _____

Date: _____

By: _____

By: _____

Christoph Dobson
District Engineer/General Manager
Under delegated authority by:
Resolution No.: SD-0267
Dated: October 11, 2017

Lisa Gonzalez
General Manager

REVIEWED AND APPROVED BY DISTRICT COUNSEL:

RECOMMENDED BY:

SacSewer Counsel

Svetlana Vorontsov
Real Estate Officer II
County of Sacramento

- ATTACH:
- Attachment 1 – Easement For Sewer
 - Attachment 2 – Temporary Construction Easement
 - Attachment 3 – Escrow Instructions

Attachment 1
Easement For Sewer

WHEN RECORDED RETURN TO:
REAL ESTATE DIVISION
COUNTY OF SACRAMENTO
3711 Branch Center Road
Sacramento, CA 95827
Mail Code 63-002

No Fee Document - Per Government Code 27383
No Document Transfer Tax - Per R & T Code 11922

Okay to Accept

Name/Date:

Print Name & Dept: Linda Peters, SacSewer

APN: 230-0080-037

Project Name & Dept: Creek Crossings Project (SacSewer) **THIS SPACE FOR RECORDER'S USE ONLY**

EASEMENT FOR SEWER

Arcade Creek Recreation & Park District, a political subdivision of the State of California, formerly known as Del Paso Recreation and Park District

(hereinafter referred to as "GRANTOR"), do(es) hereby grant to the Sacramento Area Sewer District, a county sanitation district formed pursuant to and operating under the authority of the County Sanitation District Act, commencing at Health and Safety Code section 4700, (hereinafter referred to as "SacSewer"), an easement, for sewer purposes, (hereinafter referred to as "Easement"), inclusive of digging, constructing, reconstructing, repairing, operating, upgrading and forever maintaining sanitary sewer pipelines, of such dimensions as SacSewer shall deem necessary, together with all necessary appurtenances, including the right to excavate, construct, reconstruct, repair, operate, upgrade and forever maintain said facilities appertaining thereto, including a perpetual right of way over, under, upon and across all that real property, (hereinafter referred to as "Easement Area"), situated in the County of Sacramento, State of California, described as follows:

SEE EXHIBITS "A" and "B" attached hereto and made a part hereof;

together with the perpetual right of ingress to and egress from said Easement Area, for the purpose of exercising and performing all of the rights and privileges herein granted.

Any use of this Easement Area by GRANTOR or assignees or successors in interest, shall not be allowed without the prior written approval of SacSewer; except for the following uses (collectively, the "Allowable Uses"): (i) lawn or similar groundcover; (ii) areas planted with species whose mature growth does not exceed five (5) feet in height and which are not environmentally protected; or (iii) non-colored and non-patterned asphalt and concrete driveways, sidewalks, bikepaths, surface parking, curbs and gutters. Any of said Allowable Uses shall not be installed in a manner that will impede vehicular access by SacSewer for maintenance purposes. Other than the aforementioned Allowable Uses, each use proposed by GRANTOR must be approved in writing by SacSewer's District Engineer, with said approval being in the District Engineer's sole discretion, prior to construction within or use of the Easement Area by the GRANTOR. For any required written approval, the GRANTOR shall contact the SacSewer Main Office. All use activities, including but not limited to Allowable Uses, shall not in any way limit SacSewer's rights under this Easement. Even if SacSewer's District Engineer has approved the use within the Easement Area, SacSewer retains the right to remove all or any part of the approved use to allow SacSewer to use the Easement Area at any time pursuant to the rights granted herein. Except for the Allowable Uses identified above, SacSewer shall not be liable for any cost related to the removal or replacement of said improvements constructed by GRANTOR within the Easement Area.

[Signature page follows]

RED File No. 22-12-003

LOG No. _____

[Signature page to Easement for Sewer]

Warrant of Signature Authority. The Grantor warrants the signature appearing on this instrument of real property (i.e. Easement Deed, Grant Deed, Quitclaim Deed) has the legal and requisite signatory authority for the conveyance of Grantor's real property interest. Further, the Parties acknowledge and agree that this Grantee, which is a public entity, is relying on said Warrant of Signature Authority when accepting this real property instrument for recordation.

Dated this ____ day of _____, 20____

Arcade Creek Recreation & Park District, a political subdivision of the State of California, formerly known as Del Paso Recreation and Park District

Lisa Gonzalez
General Manager

CALIFORNIA ALL-PURPOSE ACKNOWLEDGMENT

A Notary Public or other officer completing this certificate verifies only the identity of the individual who signed the document to which this certificate is attached, and not the truthfulness, accuracy, or validity of that document.

STATE OF _____)

COUNTY OF _____)

On _____ before me, _____, notary public,
date name of notary officer

personally appeared _____,
name(s) of signer(s)

who proved to me on the basis of satisfactory evidence to be the person(s) whose name(s) is/are subscribed to the within instrument and acknowledged to me that he/she/they executed the same in his/her/their authorized capacity(ies), and that by his/her/their signature(s) on the instrument the person(s), or the entity upon behalf of which the person(s) acted, executed the instrument.

I certify under PENALTY OF PERJURY under the laws of the State of California that the foregoing paragraph is true and correct.

WITNESS my hand and official seal.

 Signature of Notary

-----OPTIONAL SECTION-----

CAPACITY CLAIMED BY SIGNER

Though statute does not require the Notary to fill in the data below, doing so may prove invaluable to persons relying on the document.

- INDIVIDUAL
- CORPORATE OFFICER(S)

 Title(s)

- PARTNER(S) LIMITED
- GENERAL
- ATTORNEY-IN-FACT
- TRUSTEE(S)
- GUARDIAN/CONSERVATOR
- OTHER: _____

**SIGNER IS REPRESENTING:
 Name of Person(s) or entity(ies)**

OPTIONAL SECTION:

DATA REQUESTED HERE IS NOT REQUIRED BY LAW.

TITLE OR TYPE OF DOCUMENT: _____

NUMBER OF PAGES _____ DATE _____

SIGNER(S) OTHER THAN NAMED ABOVE _____

CERTIFICATE OF ACCEPTANCE

Sacramento Area Sewer District

This is to certify that the interest in real property conveyed by the within deed, the provisions of which are incorporated by this reference as though fully set forth in this Certification, to the Sacramento Area Sewer District, a county sanitation district formed pursuant to and operating under the authority of the County Sanitation District Act, commencing at Health and Safety Code section 4700, is hereby accepted by the undersigned officer pursuant to authority conferred by Resolution No. SD-0267 of the Board of Directors of said District adopted on October 11, 2017 and the Grantee consents to recordation thereof by its duly authorized officer.

 Christoph Dobson, District Engineer/General Manager

 Date

EXHIBIT "A"
LEGAL DESCRIPTION

All that property situated in the Unincorporated Area of Sacramento County, State of California, being a portion of Parcel No. 2 of that certain Grant Deed, recorded on October 22, 1974, in Book 7410-22, Page 156, Official Records of Sacramento County, being a strip of land of a uniform width of 20 feet, the centerline of which is more particularly described as follows:

SANITARY SEWER EASEMENT NO. 1

COMMENCING at a found 1-1/4" iron pipe, tagged "RCE 11157", at the most northwesterly corner of Lot 5 of that certain map entitled "OAK CREEK ESTATES UNIT NO. 3", filed for record on June 9, 1970, in Book 85 of Maps at Page 10, Sacramento County Records; thence southerly along the easterly line of said Parcel No. 2, South 20°06'20" West, 22.42 feet to the **POINT OF BEGINNING**;

Thence leaving said easterly line, the following four (4) courses and distances:

- (1) North 67°28'02" West, 116.34 feet;
- (2) North 00°00'00" East, 105.00 feet;
- (3) North 51°59'55" West, 285.00 feet;
- (4) North 86°50'48" West, 191.12 feet to a point hereinafter referred to as Point "A"; said Point "A" also being the **POINT OF TERMINATION** of this description.

SANITARY SEWER EASEMENT NO. 2

BEGINNING at a point on the southeasterly line of said Parcel 2, bearing South 03°09'12" West, 81.05 feet from the hereinabove mentioned Point "A"; thence leaving said southeasterly line the following four (4) courses and distances:

- (1) North 03°09'12" East, 81.05 feet to said Point "A";
- (2) North 03°09'12" East, 80.09 feet to the beginning of a curve to the right, having a radius of 200.00 feet, subtended by a chord bearing North 13°17'02" East, 70.36 feet,
- (3) northerly along said curve through a central angle of 20°15'40", an arc distance of 70.72 feet, and
- (5) North 23°24'52" East, 235.75 feet to the northerly line of said Parcel No. 2, and the **POINT OF TERMINATION** of this description.

Containing 23,012 square feet, or 0.53 acres, more or less.

Sidelines of said strips shall lengthened or shortened to the north to said northerly line of Parcel No. 2, to the south to said southeasterly line of Parcel No. 2, and to the east to said easterly line of Parcel No. 2.

Bearings and distances shown are based upon the California Coordinate System of 1983, Epoch 2010.00, Zone 2. Distances shown and described are grid and in US Survey Feet, divide the distances shown above by 0.99994 to obtain ground level distances.

This real property description and accompanied Exhibit "B" has been prepared at Mark Thomas by me, or under my direction, in conformance with the Professional Land Surveyors' Act.

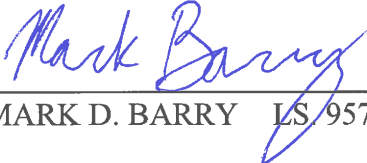

MARK D. BARRY LS 9577



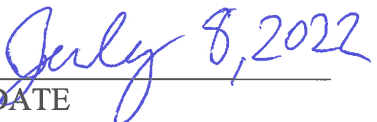

DATE

RANCHO DEL PASO

KEY MAP



Mark Barry

LEGEND

 SANITARY SEWER EASEMENT (S.S.E.)

BEARINGS AND DISTANCES SHOWN ARE BASED UPON THE CALIFORNIA COORDINATE SYSTEM OF 1983, EPOCH 2010.00, ZONE 2. DISTANCES SHOWN AND DESCRIBED ARE GRID AND IN US SURVEY FEET, DIVIDE THE DISTANCES SHOWN ABOVE BY 0.99994 TO OBTAIN GROUND LEVEL DISTANCES.

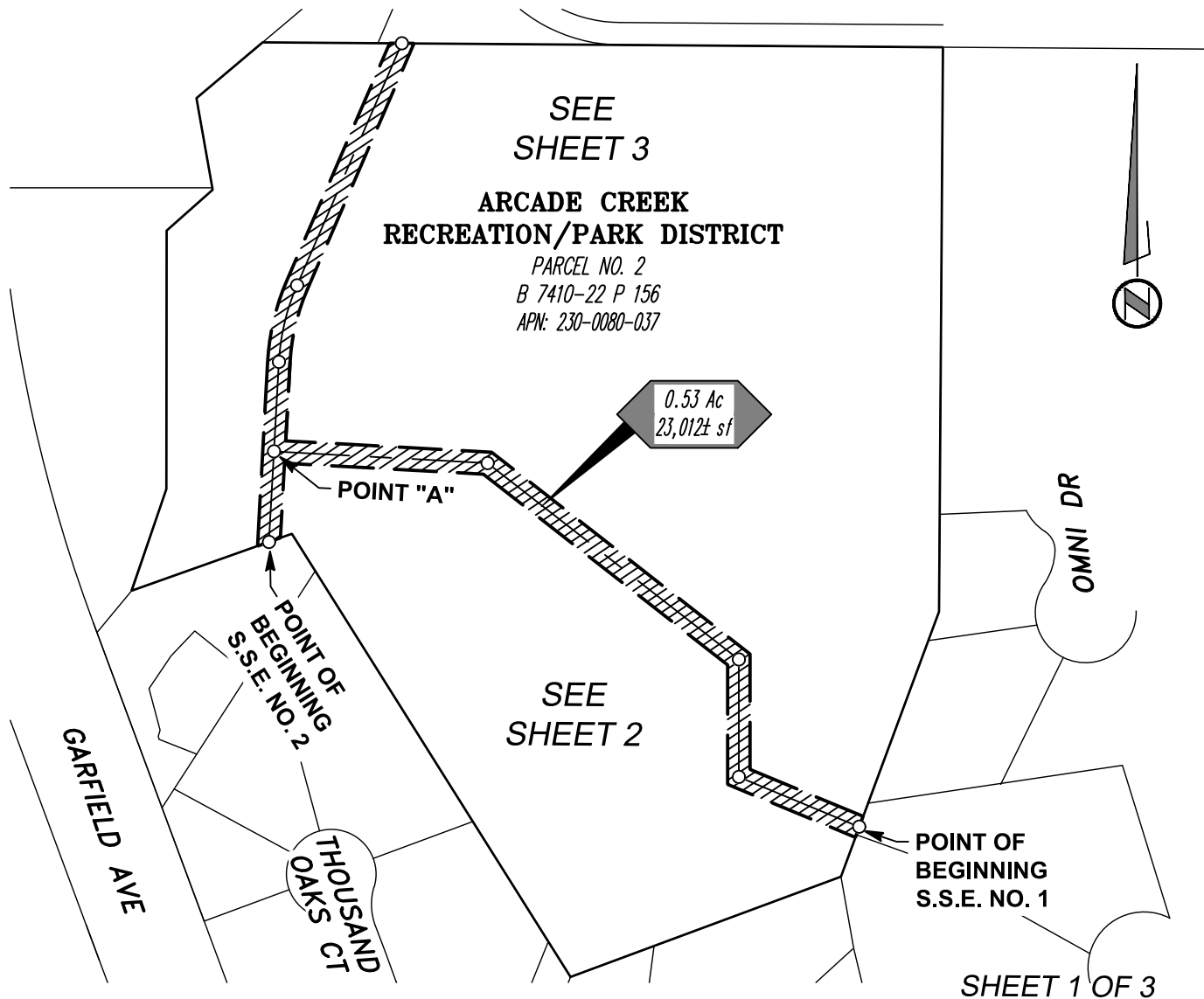
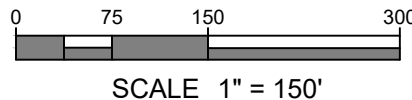

MARK THOMAS

Scale: 1" = 150'
Date July 2022
Drawn By MLP
Checked By MDB

Exhibit B
APN 230-0080-037

Plat to Accompany Legal Description
Unincorporated Area of
Sacramento County, California

SHEET 1 OF 3

LEGEND

- POC POINT OF COMMENCEMENT
- POB POINT OF BEGINNING
- POT POINT OF TERMINATION
- CB CHORD BEARING
- CH CHORD DISTANCE
- DIMENSION POINT
- FOUND 1-1/4" IRON PIPE WITH TAG
"RCE 11157" PER 85 BM 10
- ▨ SANITARY SEWER EASEMENT (S.S.E.)

RANCHO DEL PASO

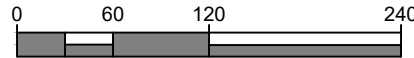

SCALE 1" = 120'

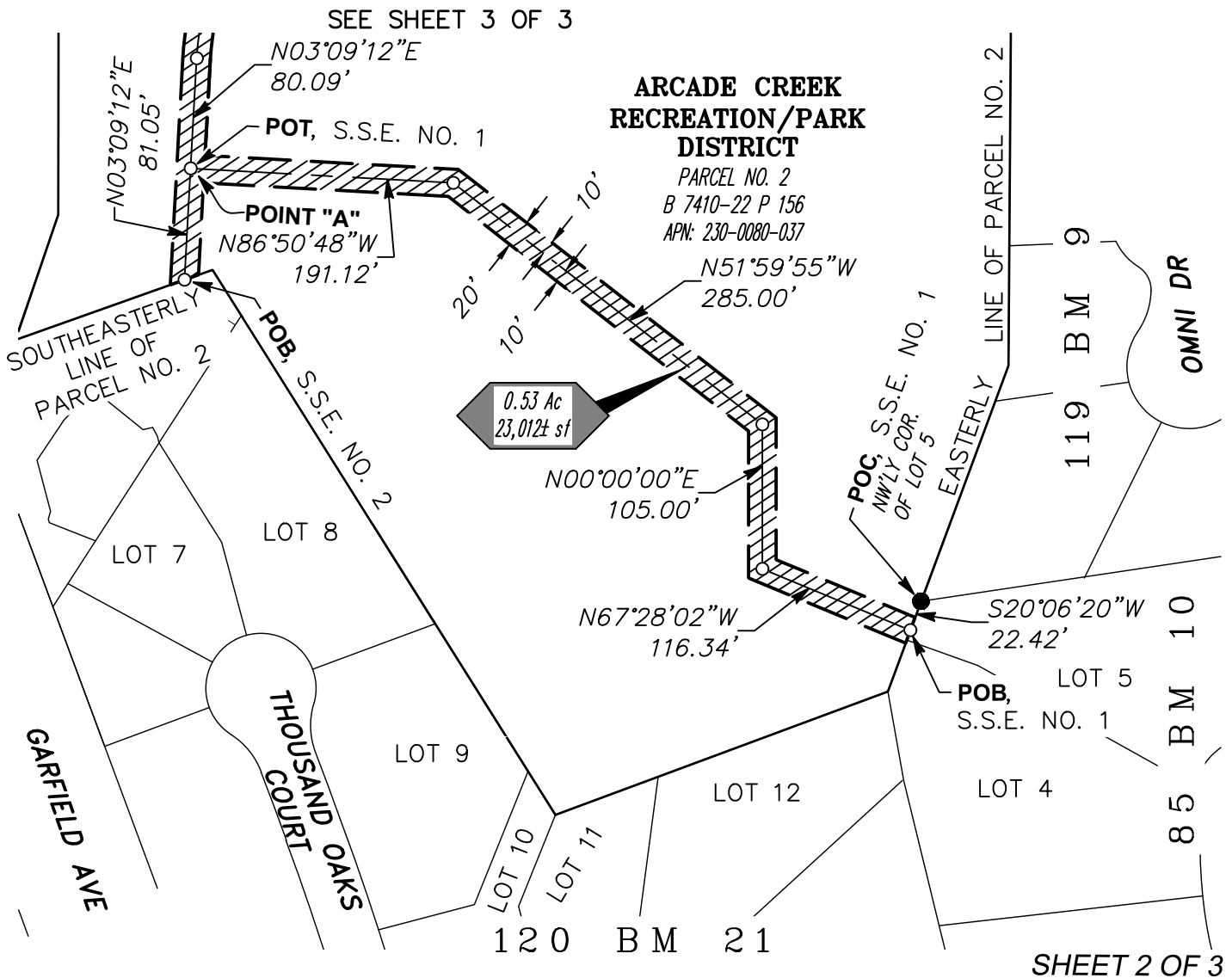

MARK THOMAS

Scale: 1" = 120'
 Date July 2022
 Drawn By MLP
 Checked By MDB

Exhibit B
 APN 230-0080-037
 Plat to Accompany Legal Description
 Unincorporated Area of
 Sacramento County, California

RANCHO DEL PASO

LEGEND

- POC POINT OF COMMENCEMENT
- POB POINT OF BEGINNING
- POT POINT OF TERMINATION
- CB CHORD BEARING
- CH CHORD DISTANCE
- DIMENSION POINT
- FOUND 1-1/4" IP WITH TAG
RCE 11157 PER 85 BM 10
- ▨ SANITARY SEWER EASEMENT (S.S.E.)

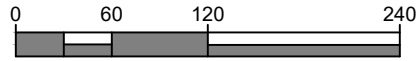
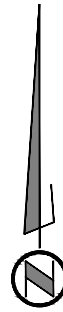

SCALE 1" = 120'

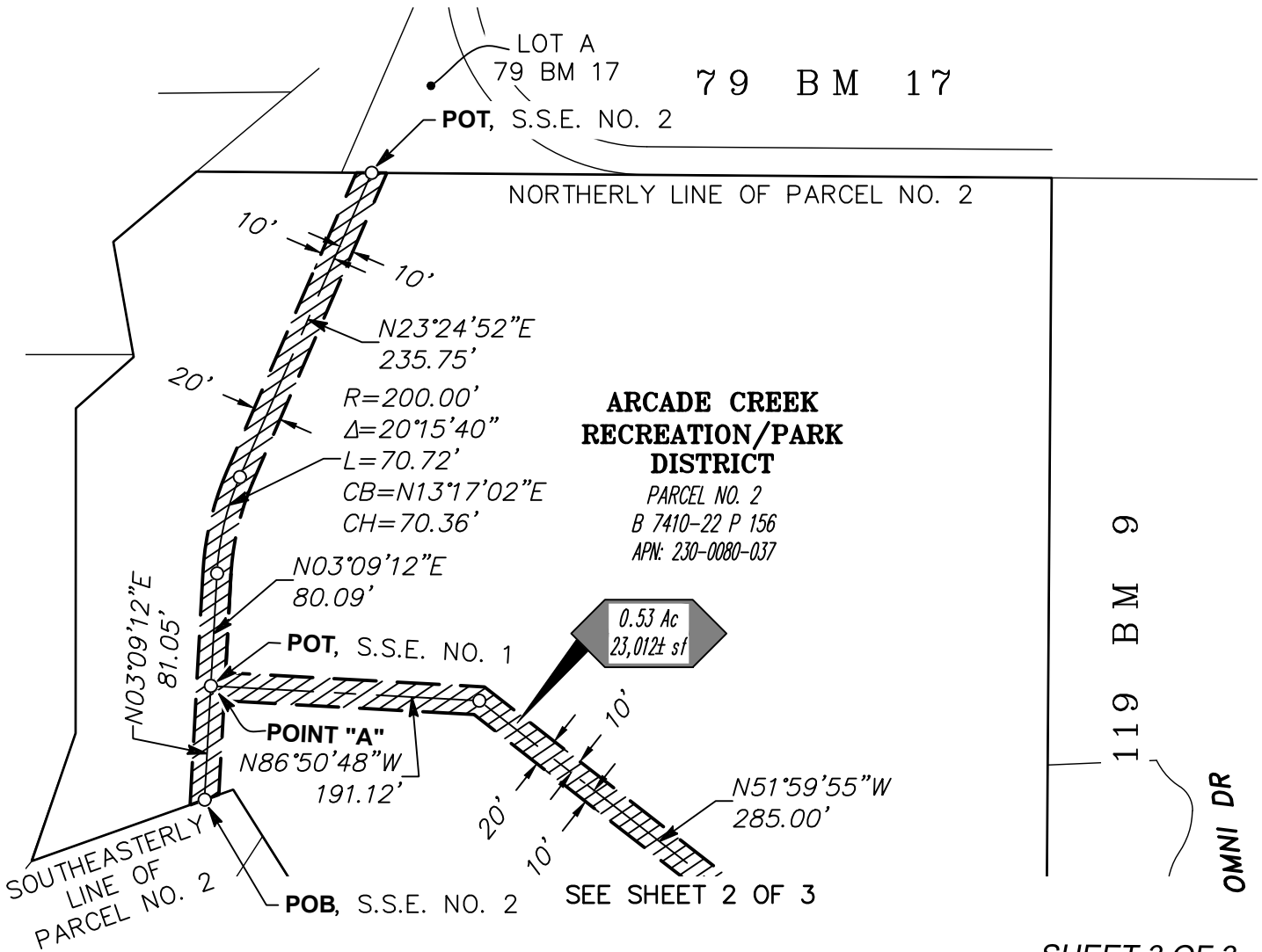

ARCADE CREEK RECREATION/PARK DISTRICT

PARCEL NO. 2
B 7410-22 P 156
APN: 230-0080-037

119 BM 9

OMNI DR

SHEET 3 OF 3



MARK THOMAS

Scale: 1" = 120'
Date July 2022
Drawn By MLP
Checked By MDB

Exhibit B
APN 230-0080-037
Plat to Accompany Legal Description
Unincorporated Area of
Sacramento County, California

Attachment 2
Temporary Construction Easement

**WHEN RECORDED RETURN TO:
REAL ESTATE DIVISION
COUNTY OF SACRAMENTO
3711 Branch Center Road
Sacramento, CA 95827
Mail Code 63-002**

**No Fee Document - Per Government Code 27383
No Document Transfer Tax - Per R & T Code 11922
Okay to Accept by**

Signature & Date:

Print Name & Dept: _____
Linda Peters, SacSewer

APNs: _____
230-0080-037 & 230-0092-037

Project Name & Dept: _____
SacSewer – Creek Crossings Project

THIS SPACE FOR RECORDER'S USE ONLY

TEMPORARY CONSTRUCTION EASEMENT

Arcade Creek Recreation & Park District, a political subdivision of the State of California, formerly known as Del Paso Recreation and Park District

(hereinafter referred to as "Owner") do(es) hereby grant to the Sacramento Area Sewer District, a county sanitation district formed pursuant to and operating under the authority of the County Sanitation District Act, commencing at Health and Safety Code section 4700 (hereinafter referred to as "SacSewer"), a Temporary Construction Easement (hereinafter referred to as "TCE") for purposes of performing activities related to and incidental to the construction of the Creek Crossings Project, (hereinafter referred to as "Project"), and other Project-related purposes upon, over and across that certain real property in the County of Sacramento, State of California, described as follows:

See Exhibit "B" attached hereto and made a part hereof;

Possession and use of the TCE area by SacSewer may commence on execution of the agreement by SacSewer (Commencement Date). This TCE shall expire thirty-six (36) months after the Commencement Date or completion of Project related construction activities on Owner's property, whichever occurs first.

Dated this _____ day of _____, 20____

Arcade Creek Recreation & Park District, a political subdivision of the State of California, formerly known as Del Paso Recreation and Park District

Lisa Gonzalez
General Manager

RED File No. 22-12-003

CALIFORNIA ALL-PURPOSE ACKNOWLEDGMENT

A Notary Public or other officer completing this certificate verifies only the identity of the individual who signed the document to which this certificate is attached, and not the truthfulness, accuracy, or validity of that document.

STATE OF _____)

COUNTY OF _____)

On _____ before me, _____, notary public,
date name of notary officer

personally appeared _____,
name(s) of signer(s)

who proved to me on the basis of satisfactory evidence to be the person(s) whose name(s) is/are subscribed to the within instrument and acknowledged to me that he/she/they executed the same in his/her/their authorized capacity(ies), and that by his/her/their signature(s) on the instrument the person(s), or the entity upon behalf of which the person(s) acted, executed the instrument.

I certify under PENALTY OF PERJURY under the laws of the State of California that the foregoing paragraph is true and correct.

WITNESS my hand and official seal.

 Signature of Notary

-----OPTIONAL SECTION-----

CAPACITY CLAIMED BY SIGNER

Though statute does not require the Notary to fill in the data below, doing so may prove invaluable to persons relying on the document.

- INDIVIDUAL
- CORPORATE OFFICER(S)

Title(s)

- PARTNER(S) LIMITED
- GENERAL

- ATTORNEY-IN-FACT
- TRUSTEE(S)
- GUARDIAN/CONSERVATOR
- OTHER: _____

SIGNER IS REPRESENTING:
 Name of Person(s) or entity(ies)

OPTIONAL SECTION:

TITLE OR TYPE OF DOCUMENT: _____
 DATA REQUESTED HERE IS NOT REQUIRED BY LAW. NUMBER OF PAGES _____ DATE _____
 SIGNER(S) OTHER THAN NAMED ABOVE _____

CERTIFICATE OF ACCEPTANCE
 Sacramento Area Sewer District

This is to certify that the interest in real property conveyed by the within deed, the provisions of which are incorporated by this reference as though fully set forth in this Certification, to the Sacramento Area Sewer District, a county sanitation district formed pursuant to and operating under the authority of the County Sanitation District Act, commencing at Health and Safety Code section 4700, is hereby accepted by the undersigned officer pursuant to authority conferred by Resolution No. SD-0267 of the Board of Directors of said District adopted on October 11, 2017 and the Grantee consents to recordation thereof by its duly authorized officer.

 Christoph Dobson, District Engineer/General Manager

 Date

LEGEND

- FOUND MONUMENT AS NOTED
- DIMENSION POINT
- ▨ TEMPORARY CONSTRUCTION EASEMENT

RANCHO DEL PASO

BEARINGS AND DISTANCES SHOWN ARE BASED UPON THE CALIFORNIA COORDINATE SYSTEM OF 1983, EPOCH 2010.00, ZONE 2. DISTANCES SHOWN AND DESCRIBED ARE GRID AND IN US SURVEY FEET, DIVIDE THE DISTANCES SHOWN ABOVE BY 0.99994 TO OBTAIN GROUND LEVEL DISTANCES.



SCALE 1" = 120'



Mark Barry

ARCADE CREEK RECREATION/PARK DISTRICT

APN: 230-0092-037
5613 OMNI DR
BK 19900514 PG 1412

TCE 1
SEE PAGE 2

FOUND 1 1/2" IRON PIPE TAGGED RCE 8850 PER 120 BM 21

TCE 2
SEE PAGE 3

ARCADE CREEK RECREATION/PARK DISTRICT

APN: 230-0092-038
5613 OMNI DR
BK 20110922 PG 871

LOT 7
120 BM 21

LOT 8
120 BM 21

ARCADE CREEK RECREATION/PARK DISTRICT

APN: 230-0080-037
5613 OMNI DR
BK 19741022 PG 156

THOUSAND OAKS COURT

SHEET 1 OF 3



MARK THOMAS

Scale: 1" = 120'
Date July 2022
Drawn By BRM
Checked By MDB

Exhibit B
APN 230-0080-037 & 230-0092-037
In the Unincorporated area of Carmichael
Sacramento County, California

LEGEND

- FOUND MONUMENT AS NOTED
- DIMENSION POINT
- ▨ TEMPORARY CONSTRUCTION EASEMENT

RANCHO DEL PASO

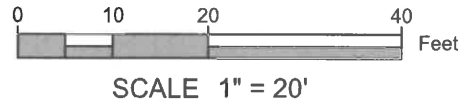

**ARCADE CREEK
RECREATION/PARK
DISTRICT**

APN: 230-0080-037
5613 OMNI DR
BK 19741022 PG 156

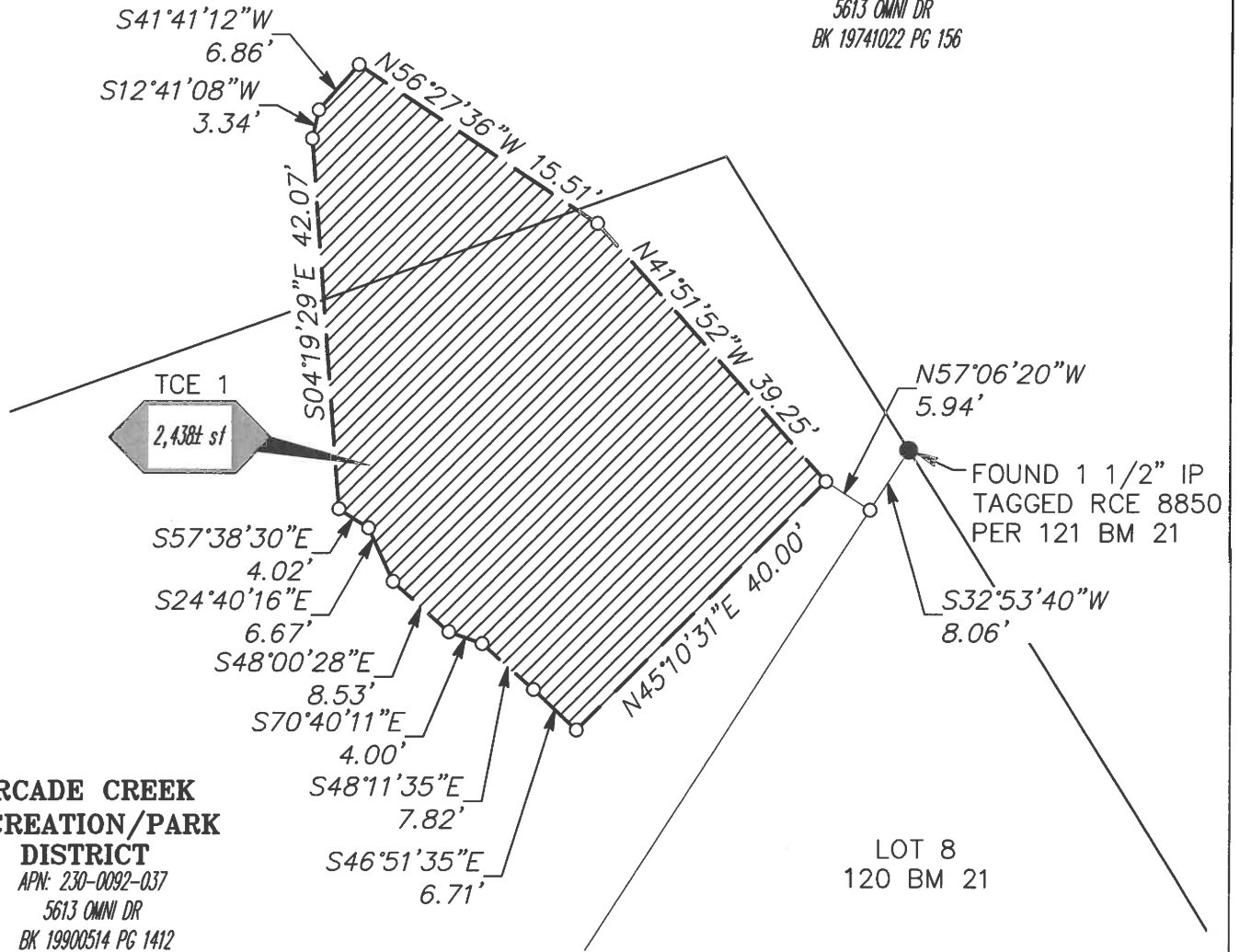

SHEET 2 OF 3



MARK THOMAS

Scale: 1" = 20'
Date July 2022
Drawn By BRM
Checked By MDB

Exhibit B
APN 230-0080-037 & 230-0092-037
In the Unincorporated area of Carmichael
Sacramento County, California

LEGEND

- FOUND MONUMENT AS NOTED
- DIMENSION POINT
- ▨ TEMPORARY CONSTRUCTION EASEMENT

RANCHO DEL PASO

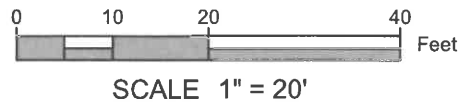

FOUND 1 1/2" IP
TAGGED RCE 8850
PER 120 BM 21

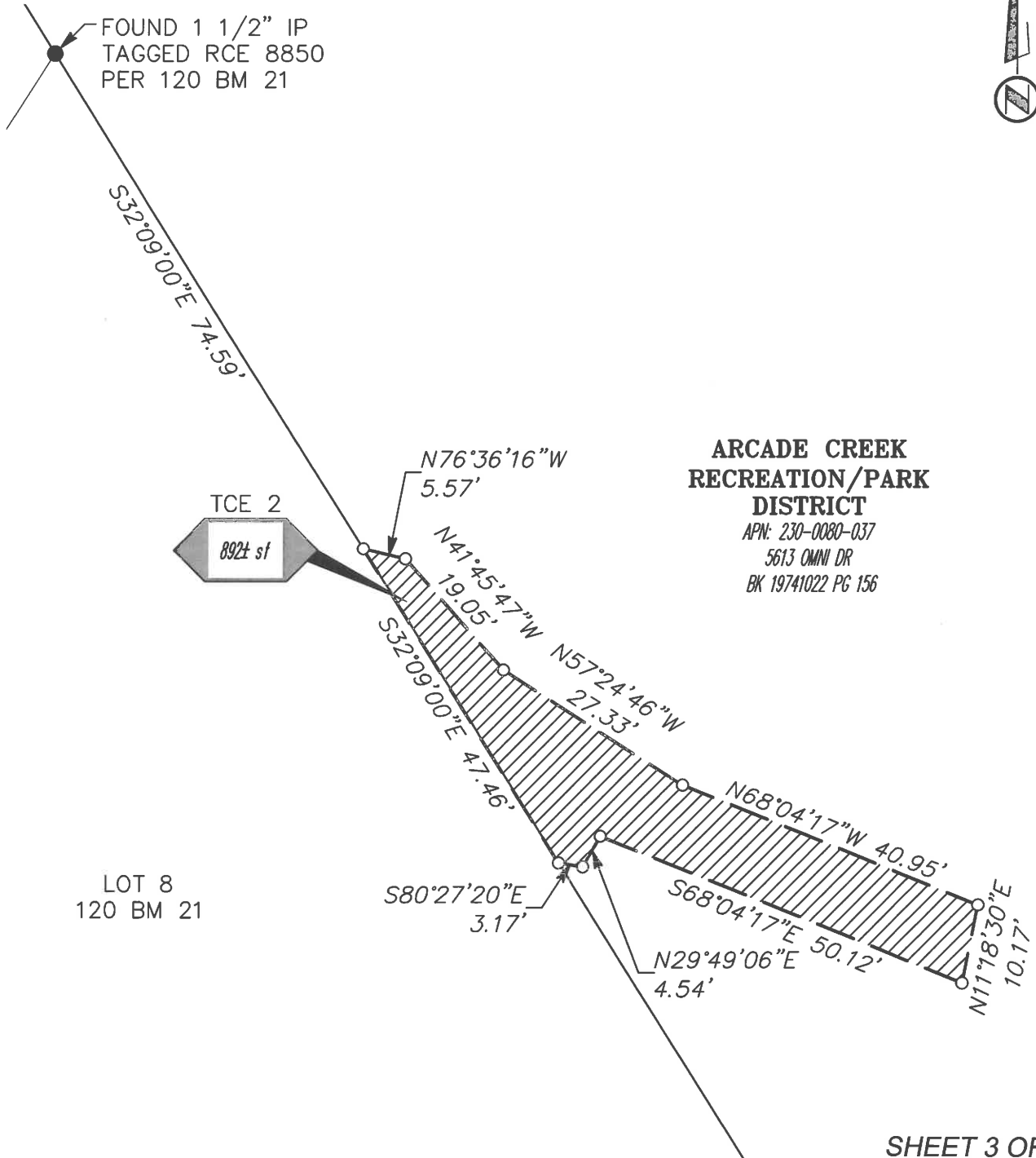

**ARCADE CREEK
RECREATION/PARK
DISTRICT**
APN: 230-0080-037
5613 OMNI DR
BK 19741022 PG 156

LOT 8
120 BM 21

SHEET 3 OF 3



MARK THOMAS

Scale: 1" = 20'
Date July 2022
Drawn By BRM
Checked By MDB

Exhibit B
APN 230-0080-037 & 230-0092-037
In the Unincorporated area of Carmichael
Sacramento County, California

ATTACHMENT 3

ESCROW INSTRUCTIONS TO:

Fidelity National Title Company
8525 Madison Avenue, Suite 110
Fair Oaks, CA 95628

Date: January 5, 2023 Escrow No: 01006739-010-AM-PJ Preliminary Report Date: September 23, 2022

Project: Creek Crossings Project

Parcel No: 230-0080-037

Property Address: 5613 Omni Drive, Arcade Creek Park, Sacramento, CA

Owner: Arcade Creek Recreation & Park District, a political subdivision of the State of California, formerly known as Del Paso Recreation and Park District

YOU ARE HANDED HEREWITH:

- 1. Demand of Grantor: \$40,920.00
2. Grant Deed (or Easement Deed), which you are authorized to deliver or record when you can issue a standard form CLTA title insurance policy with a liability in the amount of \$40,920.00 on the property as described in document handed you herewith for recording. No charge is to be paid by the SacSewer for recording.

TITLE TO BE VESTED IN: SACRAMENTO AREA SEWER DISTRICT, a county sanitation district formed pursuant to and operating under the authority of the County Sanitation District Act, commencing at Health and Safety Code section 4700

Please provide a title policy SUBJECT TO the exceptions as shown in the above cited Preliminary Report, Item(s) No. 6-20 and DELETING Item(s) No. 1-5; 21-23.

YOU ARE REQUESTED TO CLOSE THIS ESCROW AS SOON AS POSSIBLE. If you are unable to close within 30 days please advise the parties hereto.

YOU ARE AUTHORIZED TO PAY UPON CLOSING THE FOLLOWING:

Table with 4 columns: Item Number, Description, Seller, and County. Rows include: 1 Sellers Demand, 2 Title Policy, 3 Escrow Fee, all with 'Pay' in the County column.

All disbursements are to be made by check of: Fidelity National Title Company.

INSTRUCTIONS FROM SELLER: In addition to the foregoing, you are hereby authorized to record and/or deliver the attached documents to SacSewer on receipt of a warrant in the amount of \$40,920.00, net to Seller, subject to any demands of liens or encumbrances. You are also authorized to obtain a consent to easement from any Mortgagee listed in the Preliminary Report as necessary. Please remit remainder to Seller.

Seller:
By:

Lisa Gonzalez, General Manager

Email Address: lgonzalez@acrpd.com

Address:

Telephone: (916) 482-8377 phone

APPROVED:

Real Estate Division, County of Sacramento
916-876-6200

ACCEPTED:

Fidelity National Title Company
916-646-6018

Meeting Date January 19, 2023		Item # 7a
<p>Subject: Exterior lighting for both rental sites, main office, murder house and restroom building at Hamilton Street Park and Interior lighting for district rental facilities. Provided by Staples Construction Company.</p>		
<p>Initiated or requested by</p> <p><input checked="" type="checkbox"/> Board <input checked="" type="checkbox"/> Staff <input type="checkbox"/> Other</p>	<p>Item Type</p> <p><input checked="" type="checkbox"/> Informational <input checked="" type="checkbox"/> Direction</p>	<p>Report coordinated or prepared by</p> <p><i>Lisa Gonzalez & Kim Cook</i></p>
<p>Objective To remove all exterior lighting and replace it with new more efficient lighting for safety. Update and repair interior lighting in the rental facilities.</p> <p>Analysis The current exterior lighting is not providing us with the safety lighting we need to work in conjunction with our security cameras. The exterior lighting will be covered so they will not be easy to vandalize, which has been a problem in the past.</p> <p>Current light fixtures need to be upgraded to long life LED, several of the current fixtures are non-working and use florescent bulbs that are being taken off the market.</p> <p>Budget/Cost Information The budget to replace all exterior lighting is \$15,939.50, the new lighting upgrades for the rental facilities is \$27,941.89.</p> <p>The lighting estimates are itemized for the Board of Directors to review.</p> <p>Proposed Action Direct staff to enter a contract for exterior and interior lighting with Staples Construction Company.</p>		
<p>Coordination and Review This is a standard practice of the Board.</p>		<p>Attachment(s) Budget break down for Exterior lighting and interior lighting.</p>

Scope of work

Exterior lighting for Hamilton Street Park



Work Order Signature Document

EZIQC Contract No.: CA-R1-GB01-123021-STA

New Work Order

Modify an Existing Work Order

Work Order Number.: 111958.00

Work Order Date: 12/12/2022

Work Order Title: Arcade Creek - Hamilton Park R&R Lights

Owner Name: CALIFORNIA - Arcade Creek Recreation Contractor Name: Staples Construction Company, Inc.

Contact: Lisa Gonzalez Contact: Mark Hodge

Phone: 916-743-2281 Phone: (916) 210 8130

Work to be Performed

Work to be performed as per the Final Detailed Scope of Work Attached and as per the terms and conditions of Sourcewell EZIQC Contract No CA-R1-GB01-123021-STA.

Brief Work Order Description:

Hamilton Park R&R Lights

Time of Performance

Estimated Start Date:

Estimated Completion Date:

Liquidated Damages

Will apply:

Will not apply:

Work Order Firm Fixed Price: \$15,939.50

Owner Purchase Order Number:

Approvals

CALIFORNIA - Arcade Creek Recreation and Park Distr Date

Contractor Date

Detailed Scope of Work

To: Mark Hodge
Staples Construction Company

6510 Lonetree Boulevard, Suite 101
Rocklin, CA 95765
(916) 210 8130

From: Lisa Gonzalez
CALIFORNIA - Arcade Creek Recreation and
Park District
4855 Hamilton St.
Sacramento, CA 95841
916-743-2281

Date Printed: December 12, 2022

Work Order Number: 111958.00

Work Order Title: Arcade Creek - Hamilton Park R&R Lights

Brief Scope: Hamilton Park R&R Lights

Preliminary

Revised

Final

The following items detail the scope of work as discussed at the site. All requirements necessary to accomplish the items set forth below shall be considered part of this scope of work.

DSOW

- Remove and properly dispose of specified wall pack lights, flood lights, and wrap lights.
- Provide and install (18) wall pack lights, (1) flood light, and (1) wrap light. Exclusions
- Permits

- Design Drawings

Subject to the terms and conditions of EZIQC Contract **CA-R1-GB01-123021-STA**.

Contractor

Date

CALIFORNIA - Arcade Creek Recreation and Park Dist

Date

Contractor's Price Proposal - Summary

Date: December 12, 2022

Re: IQC Master Contract #: CA-R1-GB01-123021-STA
Work Order #: 111958.00
Owner PO #:
Title: Arcade Creek - Hamilton Park R&R Lights
Contractor: Staples Construction Company, Inc.
Proposal Value: \$15,939.50

Event Building	\$5,617.60
Main Office	\$5,174.12
Murder House	\$3,402.48
Restroom	\$1,745.30
Proposal Total	\$15,939.50

This total represents the correct total for the proposal. Any discrepancy between line totals, sub-totals and the proposal total is due to rounding.

The Percentage of NPP on this Proposal: %

Contractor's Price Proposal - Detail

Date: December 12, 2022

Re: IQC Master Contract #: CA-R1-GB01-123021-STA
 Work Order #: 111958.00
 Owner PO #:
 Title: Arcade Creek - Hamilton Park R&R Lights
 Contractor: Staples Construction Company, Inc.
 Proposal Value: \$15,939.50

Sect.	Item	Mod.	UOM	Description	Line Total
Labor	Equip.	Material	(Excludes)		
Event Building					
1	26 05 29 00 0168		EA	3/4", One Hole Steel Conduit Strap	\$25.01
				Quantity	Unit Price
				Installation	Factor = Total
				4.00 x 3.68 x 1.6988 = 25.01	
				Used to strap conduit for new wall packs.	
2	26 05 33 13 0601		LF	3/4" Electrical Metallic Tubing (EMT) Conduit	\$179.50
				Quantity	Unit Price
				Installation	Factor = Total
				18.00 x 5.87 x 1.6988 = 179.50	
				(3) wall packs require minor conduit runs to add or relocate wall packs.	
3	26 56 19 00 0030		EA	6,451 Lumens, 52 Watt, 2 LEDs, Wall Mounted Security Fixture (Jarvis Corp WMFT-250)	\$5,413.09
				Quantity	Unit Price
				Installation	Factor = Total
				8.00 x 352.69 x 1.6988 = 4,793.20	
				Demolition	Factor = Total
				5.00 x 72.98 x 1.6988 = 619.89	
				Used for Lumark Crosstour Led Wall Pack Series XTOR3BPC1.	
Subtotal for Event Building					\$5,617.60
Main Office					
4	26 05 29 00 0168		EA	3/4", One Hole Steel Conduit Strap	\$12.50
				Quantity	Unit Price
				Installation	Factor = Total
				2.00 x 3.68 x 1.6988 = 12.50	
				Used to strap conduit for new wall packs.	
5	26 05 33 13 0601		LF	3/4" Electrical Metallic Tubing (EMT) Conduit	\$99.72
				Quantity	Unit Price
				Installation	Factor = Total
				10.00 x 5.87 x 1.6988 = 99.72	
				(1) wall pack on the main building needs relocating of roughly 10' and requires a minor conduit run.	
6	26 56 19 00 0030		EA	6,451 Lumens, 52 Watt, 2 LEDs, Wall Mounted Security Fixture (Jarvis Corp WMFT-250)	\$5,061.90
				Quantity	Unit Price
				Installation	Factor = Total
				7.00 x 352.69 x 1.6988 = 4,194.05	
				Demolition	Factor = Total
				7.00 x 72.98 x 1.6988 = 867.85	
				Used for Lumark Crosstour Led Wall Pack Series XTOR3BPC1.	
Subtotal for Main Office					\$5,174.12
Murder House					
7	26 55 53 11 0229		EA	80 LEDs, 90 Watt, Adjustable Arm Mount, Rectangular, LED Flood Light (CREE® BetaLED® Edge® FLD-EDG)	\$2,679.35
				Quantity	Unit Price
				Installation	Factor = Total
				1.00 x 1,462.98 x 1.6988 = 2,485.31	
				Demolition	Factor = Total
				1.00 x 114.22 x 1.6988 = 194.04	
				Used for R&R on (1) LED flood light at the top peak of the murder house.	

Contractor's Price Proposal - Detail Continues..

Work Order Number: 111958.00
Work Order Title: Arcade Creek - Hamilton Park R&R Lights

Murder House

8	26 56 19 00 0030	EA	6,451 Lumens, 52 Watt, 2 LEDs, Wall Mounted Security Fixture (Jarvis Corp WMFT-250)						\$723.13
			Quantity		Unit Price		Factor	=	Total
		Installation	1.00	x	352.69	x	1.6988	=	599.15
		Demolition	1.00	x	72.98	x	1.6988	=	123.98
		Used for Lumark Crosstour Led Wall Pack Series XTOR3BPC1.							

Subtotal for Murder House **\$3,402.48**

Restroom

9	26 51 19 00 0273	EA	4' Length, 4,000 Lumens, Surface Mount, Wraparound LED Fixture (Lithonia LBL4)						\$547.00
			Quantity		Unit Price		Factor	=	Total
		Installation	1.00	x	288.60	x	1.6988	=	490.27
		Demolition	1.00	x	33.39	x	1.6988	=	56.72
		Used for R&R on (1) wrap light in the women's restroom.							
10	26 56 19 00 0030	EA	6,451 Lumens, 52 Watt, 2 LEDs, Wall Mounted Security Fixture (Jarvis Corp WMFT-250)						\$1,198.30
			Quantity		Unit Price		Factor	=	Total
		Installation	2.00	x	352.69	x	1.6988	=	1,198.30
		Used for Lumark Crosstour Led Wall Pack Series XTOR3BPC1.							

Subtotal for Restroom **\$1,745.30**

Proposal Total **\$15,939.50**

This total represents the correct total for the proposal. Any discrepancy between line totals, sub-totals and the proposal total is due to rounding.

The Percentage of NPP on this Proposal: %

Subcontractor Listing

Date: December 12, 2022

Re: IQC Master Contract #: CA-R1-GB01-123021-STA
Work Order #: 111958.00
Owner PO #:
Title: Arcade Creek - Hamilton Park R&R Lights
Contractor: Staples Construction Company, Inc.
Proposal Value: \$15,939.50

Name of Contractor	Duties	Amount	%
No Subcontractors have been selected for this Work Order		\$0.00	0.00

Scope of work

**Interior lighting for Hamilton Street Park
Rental Facilities**



Work Order Signature Document

EZIQC Contract No.: CA-R1-GB01-123021-STA

New Work Order

Modify an Existing Work Order

Work Order Number.: 112741.00

Work Order Date: 01/12/2023

Work Order Title: ACRPD Interior Lighting

Owner Name: CALIFORNIA - Arcade Creek Recreation Contractor Name: Staples Construction Company, Inc.

Contact: Lisa Gonzalez Contact: Mark Hodge

Phone: 916-743-2281 Phone: (916) 210 8130

Work to be Performed

Work to be performed as per the Final Detailed Scope of Work Attached and as per the terms and conditions of Sourcewell EZIQC Contract No CA-R1-GB01-123021-STA.

Brief Work Order Description:

ACRPD Interior Lighting

Time of Performance

Estimated Start Date:

Estimated Completion Date:

Liquidated Damages

Will apply:

Will not apply:

Work Order Firm Fixed Price: \$27,941.89

Owner Purchase Order Number:

Approvals

CALIFORNIA - Arcade Creek Recreation and Park Distr Date

Contractor Date

Detailed Scope of Work

To: Mark Hodge
Staples Construction Company

6510 Lonetree Boulevard, Suite 101
Rocklin, CA 95765
(916) 210 8130

From: Lisa Gonzalez
CALIFORNIA - Arcade Creek Recreation and
Park District
4855 Hamilton St.
Sacramento, CA 95841
916-743-2281

Date Printed: January 12, 2023

Work Order Number: 112741.00

Work Order Title: ACRPD Interior Lighting

Brief Scope: ACRPD Interior Lighting

Preliminary

Revised

Final

The following items detail the scope of work as discussed at the site. All requirements necessary to accomplish the items set forth below shall be considered part of this scope of work.

DSOW

- Remove and reinstall acoustical ceiling tiles for access.
- Remove and dispose of (30) thirty 2' x 4' T-Bar lay-in fluorescent troffer fixtures, (5) five 2' x 4' surface mount fluorescent troffer fixtures, and (1) one 4' surface mount wrap light.
- Remove ballasts from the fixtures and recycle them.
- Install (30) thirty 2' x 4' T-Bar lay-in LED troffer fixtures, (5) five 2' x 4' surface mount LED troffer fixtures, and (1) one 4' surface mount LED wrap light.
- Use existing raceways, wiring, and openings.

Exclusions

- Permits or Fees

Subject to the terms and conditions of EZIQC Contract **CA-R1-GB01-123021-STA.**

Contractor

Date

CALIFORNIA - Arcade Creek Recreation and Park Dist

Date

Contractor's Price Proposal - Summary

Date: January 12, 2023

Re: IQC Master Contract #: CA-R1-GB01-123021-STA
Work Order #: 112741.00
Owner PO #:
Title: ACRPD Interior Lighting
Contractor: Staples Construction Company, Inc.
Proposal Value: \$27,941.89

Section - 01	\$2,550.99
Section - 02	\$576.10
Section - 09	\$4,246.73
Section - 26	\$20,568.07
Proposal Total	\$27,941.89

This total represents the correct total for the proposal. Any discrepancy between line totals, sub-totals and the proposal total is due to rounding.

The Percentage of NPP on this Proposal: %

Contractor's Price Proposal - Detail

Date: January 12, 2023

Re: IQC Master Contract #: CA-R1-GB01-123021-STA
 Work Order #: 112741.00
 Owner PO #:
 Title: ACRPD Interior Lighting
 Contractor: Staples Construction Company, Inc.
 Proposal Value: \$27,941.89

Sect.	Item	Mod.	UOM	Description	Line Total
Labor	Equip.	Material	(Excludes)		
Section - 01					
1	01 22 16 00 0002		EA	Reimbursable Fees Reimbursable Fees will be paid to the contractor for eligible costs as directed by Owner. Insert the appropriate quantity to adjust the base cost to the actual Reimbursable Fee. If there are multiple Reimbursable Fees, list each one separately and add a comment in the "note" block to identify the Reimbursable Fee (e.g. sidewalk closure, road cut, various permits, extended warranty, expedited shipping costs, etc.). A copy of each receipt shall be submitted with the Price Proposal.	\$600.60
				Installation	
				Quantity	
				546.00 x	
				Unit Price	
				1.00 x	
				Factor	
				1.1000 =	
				Total	600.60
				Used for the estimated bond if required.	
2	01 66 19 00 0047		CY	Transfer Delivered Materials Distances Greater Than 125', Per CY Of Material Per 125'	\$856.28
				Installation	
				Quantity	
				85.00 x	
				Unit Price	
				5.93 x	
				Factor	
				1.6988 =	
				Total	856.28
				Used to transfer new boxed fixtures to the work area. 36 fixtures with a box of 2' x 4' x 8" depth = 85 cubic yards.	
3	01 66 19 00 0073		CY	Transfer Demolition Debris Distances Greater Than 125', Per CY Of Material Per 125'	\$423.10
				Installation	
				Quantity	
				42.00 x	
				Unit Price	
				5.93 x	
				Factor	
				1.6988 =	
				Total	423.10
				Used the same concept as the above line item but reduced the depth by 4" as there is no box.	
4	01 74 19 00 0012		EA	10 CY Dumpster (1.5 Ton) "Construction Debris" Includes delivery of dumpster, rental cost, pick-up cost, hauling, and disposal fee. Non-hazardous material.	\$671.01
				Installation	
				Quantity	
				1.00 x	
				Unit Price	
				394.99 x	
				Factor	
				1.6988 =	
				Total	671.01
				Used to dispose of removed existing fixtures.	
Subtotal for Section - 01					\$2,550.99
Section - 02					
5	02 84 16 00 0002		EA	Removal Of TSCA-Exempt Polychlorinated Biphenyl (PCB) And Non-PCB Ballast From A Demolished Fixture For Recycling	\$489.87
				Installation	
				Quantity	
				36.00 x	
				Unit Price	
				8.01 x	
				Factor	
				1.6988 =	
				Total	489.87
				Used to remove ballasts from fixtures.	
6	02 84 16 00 0004		EA	Recycle Non-Polychlorinated Biphenyl (PCB) Ballast Removed From Up To 4' Length Fixtures	\$86.23
				Installation	
				Quantity	
				36.00 x	
				Unit Price	
				1.41 x	
				Factor	
				1.6988 =	
				Total	86.23
				Used to recycle removed ballasts from fixtures.	
Subtotal for Section - 02					\$576.10
Section - 09					

Contractor's Price Proposal - Detail Continues..

Work Order Number: 112741.00
Work Order Title: ACRPD Interior Lighting

Section - 09

7	09 51 13 00 0047	SF	Removal And Reinstallation Of Acoustical Panels Only						\$4,246.73
		Installation	Quantity	Unit Price	Factor	=	Total		
			1,152.00	2.17	1.6988		4,246.73		
			x	x					
		Used to remove and reinstall ceiling tiles around old and new fixtures to allow working space for the electricians. Estimated 32 SF around a fixture at 36 fixtures = 1152 SF							

Subtotal for Section - 09 **\$4,246.73**

Section - 26

8	26 01 20 91 0003	EA	Lock Out/Tag Out Breaker Or Motor StarterExcludes tag or padlock See CSI section 26 01 20 91-0004 for padlock, 26 01 20 91-0005 for tag(s).						\$306.04
		Installation	Quantity	Unit Price	Factor	=	Total		
			5.00	36.03	1.6988		306.04		
			x	x					
		Used for estimated lockouts to change fixtures.							
9	26 01 20 91 0004	EA	Lock Out/Tag Out Padlock Device						\$85.02
		Installation	Quantity	Unit Price	Factor	=	Total		
			5.00	10.01	1.6988		85.02		
			x	x					
		LOTO							
10	26 01 20 91 0005	EA	Lock Out/Tag Out Tags						\$26.59
		Installation	Quantity	Unit Price	Factor	=	Total		
			5.00	3.13	1.6988		26.59		
			x	x					
		LOTO							
11	26 51 16 00 0059	EA	4 T5 Lamps, 2' x 4', Prismatic Lensed, Lay-In/Troffer Fluorescent Fixture						\$2,599.78
		Installation	Quantity	Unit Price	Factor	=	Total		
			0.00	499.20	1.6988		0.00		
			x	x					
		Demolition	Quantity	Unit Price	Factor	=	Total		
			36.00	42.51	1.6988		2,599.78		
			x	x					
		Used to remove 36 existing fluorescent fixtures.							
12	26 51 19 00 0144	EA	2' x 4', 4,800 Lumens, Volumetric, Lay-In/Troffer LED Fixture (Lithonia 2RTL4)						\$14,589.97
		Installation	Quantity	Unit Price	Factor	=	Total		
			30.00	286.28	1.6988		14,589.97		
			x	x					
		Used install (30) thirty new 2' x 4' T-Bar lay-in LED troffer fixtures. Proposed Lithonia fixtures were sent to the client.							
13	26 51 19 00 0263	EA	2' x 4', 3,000 Lumens, Surface Mount, Volumetric LED Fixture (Lithonia 2RTX4)						\$2,470.40
		Installation	Quantity	Unit Price	Factor	=	Total		
			5.00	290.84	1.6988		2,470.39		
			x	x					
		Used to R&R (5) 2' x 4' surface mount troffer light fixtures with proposed Lithonia LED Fixtures. Proposed Lithonia fixtures were sent to the client.							
14	26 51 19 00 0273	EA	4' Length, 4,000 Lumens, Surface Mount, Wraparound LED Fixture (Lithonia LBL4)						\$490.27
		Installation	Quantity	Unit Price	Factor	=	Total		
			1.00	288.60	1.6988		490.27		
			x	x					
		Used to R&R (1) wrap fixture.							

Subtotal for Section - 26 **\$20,568.07**

Proposal Total **\$27,941.89**

This total represents the correct total for the proposal. Any discrepancy between line totals, sub-totals and the proposal total is due to rounding.

The Percentage of NPP on this Proposal: %

Subcontractor Listing

Date: January 12, 2023

Re: IQC Master Contract #: CA-R1-GB01-123021-STA
Work Order #: 112741.00
Owner PO #:
Title: ACRPD Interior Lighting
Contractor: Staples Construction Company, Inc.
Proposal Value: \$27,941.89

Name of Contractor	Duties	Amount	%
No Subcontractors have been selected for this Work Order		\$0.00	0.00



Catalog Number
Notes
Type

Contractor Select™
CPX™
 LED Panel

CPX™ from Lithonia lighting is the perfect choice for a quality LED panel at an affordable price. The smooth, even lens projects a crisp and clean aesthetic. CPX is the perfect choice for budget-conscious school, commercial office, or small retail footprint projects.

FEATURES:

- Industry standard wattages
- Long-life LEDs maintain greater than 70% of their lumen output at 50,000 hours
- 0-10V dimming driver, dims to 10%

WEIGHT:

2x2
 Unit: 6.39lbs
 Unit Carton: 7.72lbs
 Master Carton: 30.42lbs

2x4
 Unit: 11.02lbs
 Unit Carton: 13.89lbs
 Master Carton: 27.78lbs



Catalog Number	UPC	Description	Lumens	Input Watts	CCT	CRI	Voltage	Pallet qty.
CPX 2X2 3200LM 35K M4	191848338537	2x2 LED Panel	3555	31.5	3500K	80	120-277V	40
CPX 2X2 3200LM 40K M4	191848338650	2x2 LED Panel	3659	31.5	4000K	80	120-277V	40
CPX 2X2 3200LM 50K M4	193048313642	2x2 LED Panel	3737	31.5	5000K	80	120-277V	40
CPX 2X4 4000LM 35K M2	191848338490	2x4 LED Panel	4543	38.9	3500K	80	120-277V	20
CPX 2x4 4000LM 40K M2	191848338506	2x4 LED Panel	4692	38.9	4000K	80	120-277V	20
CPX 2X4 4000LM 50K M2	193048313680	2x4 LED Panel	4766	38.9	5000K	80	120-277V	20
CPX 1X4 AL07 SWW7 M4	194994568063	1X4 Switchable Panel	See Switchable Table	See Switchable Table	3500K/4000K/5000K	>80	120-277V	40
CPX 2X2 AL07 SWW7 M4	193048542806	2X2 Switchable Panel	See Switchable Table	See Switchable Table	3500K/4000K/5000K	>80	120-277V	40
CPX 2X4 AL08 SWW7 M2	193048542844	2X4 Switchable Panel	See Switchable Table	See Switchable Table	3500K/4000K/5000K	>80	120-277V	20

NOTES

1. ILBLP CP10 HE SD A remote mounted only. See [ILBLP CP10 HE SD B spec sheet](#) and [ELA-PSMK-PSMKSD-PSDMT-PSRME remote mounting enclosure spec sheet here](#).



Accessories: Order as separate catalog number.

ILBLP CP10 HE SD A	IOTA 10 Watt Constant Power, High Efficiency LED Emergency Driver for CA Title 20 ¹
DGA14	Drywall grid adapter for 1X4 recessed fixture.
DGA22	Drywall grid adapter for 2x2 recessed fixture.
DGA24	Drywall grid adapter for 2x4 recessed fixture.
1X4SMKSH	Multi-Use Surface Mount Kit 1X4, Shallow Depth
2X2SMKSH	Multi-Use Surface Mount Kit 2x2, Shallow Depth
2X4SMKSH	Multi-Use Surface Mount Kit 2x4, Shallow Depth
1X4SMKSH PAF	Multi-Use Surface Mount Kit 1X4 Post-Paint
2X2SMKSH PAF	Multi-Use Surface Mount Kit 2X2 Post-Paint
2X4SMKSH PAF	Multi-Use Surface Mount Kit 2X4 Post-Paint
PAC 2DNF 36	Panel Air Craft Kit, 2 cables with Y splitter, No Power Feed, 36 inches. Recommended for 1X4 or 2X2 Panel Fixtures only.
PAC 2DF 36	Panel Air Craft Kit, 2 cables with Y splitter, with Power Feed, 36 inches. Recommended for 1X4 or 2X2 Panel Fixtures only. ¹
PAC 4DNF 36	Panel Air Craft Kit, 4 cables, No Power Feed, 36 inches. Recommended for 2X4, 1X4 or 2X2 Panel Fixtures.
PAC 4DF 36	Panel Air Craft Kit, 4 cables, with Power Feed, 36 inches. Recommended for 2X4, 1X4 or 2X2 Panel Fixtures. ¹
PAC 2DNF 72	Panel Air Craft Kit, 2 cables with Y splitter, No Power Feed 72 inches. Recommended for 1X4 or 2X2 Panel Fixtures only.
PAC 2DF 72	Panel Air Craft Kit, 2 cables with Y splitter, with Power Feed, 72 inches. Recommended for 1X4 or 2X2 Panel Fixtures only. ¹
PAC 4DNF 72	Panel Air Craft Kit, 4 cables, No Power Feed, 72 inches. Recommended for 2X4, 1X4 or 2X2 Panel Fixtures.
PAC 4DF 72	Panel Air Craft Kit, 4 cables, with Power Feed, 72 inches. Recommended for 2X4, 1X4 or 2X2 Panel Fixtures. ¹
RK8BDP 2P U	Disconnect Plug (BDP), 2 Pole, Package of 1
RK8BDP 3P U	Disconnect Plug (BDP), 3 Pole, Package of 1
RK8BDP 2P J10	Disconnect Plug (BDP), 2 Pole, Package of 10
RK8BDP 2P J40	Disconnect Plug (BDP), 2 Pole, Package of 40

Switchable Table						
Size(ft)	Nomenclature	Lumen Package	CCT	Lumen	Wattage	Efficacy
1x4	CPX 1X4 AL07 SWW7 M4	Low Lumen	3500K	2430	19.7	123.4
			4000K	2594	19.7	131.7
			5000K	2483	19.5	127.3
		Med Lumen	3500K	3289	28.4	115.8
			4000K	3583	27.2	131.7
			5000K	3369	28.2	119.5
		High Lumen	3500K	3914	35.7	109.6
			4000K	4280	33.7	127
			5000K	4009	35.5	112.9
2x2	CPX 2X2 AL07 SWW7 M4	Low Lumen	3500K	2399	19.1	125.6
			4000K	2570	18.5	138.9
			5000K	2456	19.1	128.6
		Med Lumen	3500K	3356	28.7	116.9
			4000K	3649	27.5	132.7
			5000K	3427	28.5	120.2
		High Lumen	3500K	4131	37.5	110.2
			4000K	4564	35.8	127.5
			5000K	4212	37.3	112.9
2x4	CPX 2X4 AL08 SWW7 M2	Low Lumen	3500K	3813	28.94	131.8
			4000K	4033	28.1	143.5
			5000K	3938	28.86	136.5
		Med Lumen	3500K	4677	36.8	127.1
			4000K	5009	35.55	140.9
			5000K	4834	36.65	131.9
		High Lumen	3500K	6048	50.56	119.6
			4000K	6563	48.53	135.2
			5000K	6241	50.24	124.2

NOTES

1. For MVOLT only, not available with 347V.



Specifications

INTENDED USE:

CPX is a low-glare panel featuring an external driver. This cost-effective, reliable panel is visually comfortable and can be recessed mounted. Suitable for many applications such as schools, offices, retail, convenience stores and other commercial spaces. **Certain airborne contaminants can diminish integrity of acrylic.** [Click here for Acrylic Environmental Compatibility table for suitable uses.](#) Adjustable Lumen (ALO7, ALO8) and Switchable White (SWW7) configurations available. **U.S. Patent No. 10,681,784.**

CONSTRUCTION:

The extruded aluminum frame with satin white lens provides excellent shielding and uniform luminance. The low-profile design of CPX provides increased installation flexibility especially in restricted plenum spaces. The backplate includes integral T-bar clips for installation into T-grid ceilings.

ELECTRICAL:

Long-life LEDs, coupled with a high-efficiency driver, provide superior illumination for extended service life. Greater than 70% LED lumen maintenance at 50,000 hours (L70>50,000). 0-10V dimming driver, dims to 10% and contains non-isolated dimming leads.

LISTINGS:

CSA certified to meet US and Canadian standards. Damp location listed. IC rated. IP5X Rated. DesignLights Consortium® (DLC) qualified product. Not all versions of this product may be DLC qualified. Please check the DLC Qualified Products List at www.designlights.org/QPL to confirm which versions are qualified. Rated for NSF/ANSI Standard 2 - Light Fixture for Splash Zone and Non Food Zone. NOM Certified.

WARRANTY:

5-year limited warranty. This is the only warranty provided and no other statements in this specification sheet create any warranty of any kind. All other express and implied warranties are disclaimed. Complete warranty terms located at: www.acuitybrands.com/support/warranty/terms-and-conditions

Note: Actual performance may differ as a result of end-user environment and application. All values are design or typical values, measured under laboratory conditions at 25 °C. Specifications subject to change without notice.

Dimensions

2'x2'

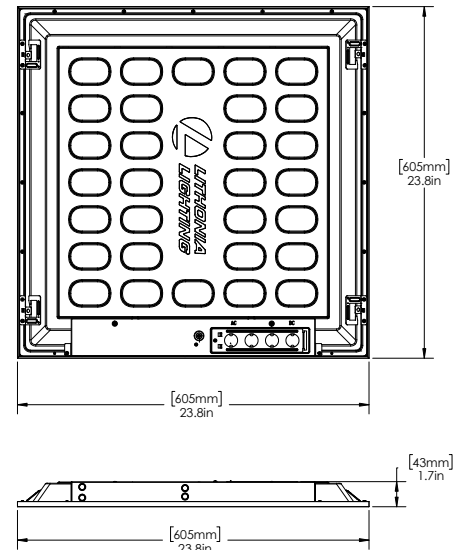

2'x4'

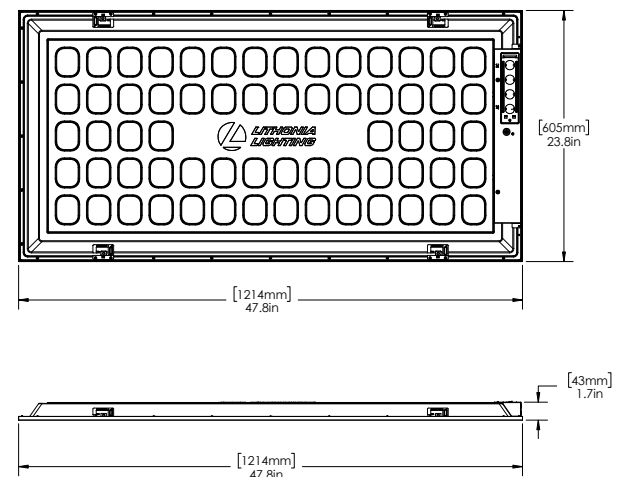

All dimensions are inches (millimeters) unless otherwise indicated.

Meeting Date January 19, 2023		Item # 7 b
		New Business
Subject: Provisions of AB 361 Re-Codified with AB 2449 Teleconferencing and remain in compliance with the Brown Act.		
Initiated or requested by <input type="checkbox"/> Board <input type="checkbox"/> Staff <input checked="" type="checkbox"/> Other	Item Type <input checked="" type="checkbox"/> Informational <input checked="" type="checkbox"/> Direction <input type="checkbox"/> Action	Report coordinated or prepared by <i>Kim Cook</i> Office Manager
Objective Revise teleconferencing in specified scenarios by ending AB 361 and re-codified to AB 2449.		
Background <p>The Brown Act required that if the legislative body of a local agency elects to use teleconferencing, it shall post agendas at all teleconference locations and conduct teleconference meeting in a manner that protects the statutory and constitutional rights of the parties or the public appearing before the legislative body of a local agency.</p> <p>Starting in March 2020, amid rising concern surrounding the spread of COVID-19. California Governor Newsom issued a series of Executive Orders aimed at containing the novel coronavirus. These Executive Orders collectively modified certain requirements created by the Ralph M. Brown Act, specifically in reference to teleconferencing.</p> <p>To address this issue, AB 361 provided relief from the obligation to post meeting agendas at all conference locations. Since October 2021, the district has been adopting a resolution during the monthly board of directors meeting authorizing remote teleconferencing meeting pursuant to Brown Act Provision.</p>		
Analysis <p>The teleconferencing provisions of AB 361 do not expire until January 1, 2024. However, Governor Newsom announced that the COVID-19 State of Emergency will end on February 28, 2023, meaning public agencies will no longer have the necessary authority to hold virtual meetings under the provisions of AB 361 after that date.</p> <p>AB 2449 reiterates the standard Brown Act teleconference rules, re-codifies the rules set out in AB 361 for times of declared emergency, and provides for relaxed teleconferencing rules when a member of the legislative body needs to attend remotely for an emergency, or other reasons supported by “just cause”.</p>		
Budget/Cost Information None		
Proposed Action Follow the guidelines for AB 2449 Limited Teleconferencing in specified scenarios.		

Alternative Actions

Follow the Brown Act.

Coordination and Review

This is a standard practice of the Board.

Attachment(s)

- 1) What to Know About Brown Act Legislation
- 2) Brown Act Updates: Continued Remote Meetings

What to Know About Brown Act Legislation (ref: CSDA)

[Assembly Bill 2449 \(Rubio\)](#) establishes a new avenue for a minority of a local agency's board to meet remotely without noticing or providing public access to their remote meeting location under modified Brown Act requirements provided that the agency abides by the strict substantive and procedural requirements within the legislation. Local agencies may avail themselves of the alternative agenda posting and teleconference requirements, potentially making it easier for local agency board members to participate in a meeting remotely under certain circumstances that would've otherwise precluded that participation.

AB 2449 passed the State Senate last week on a 36-3-1 vote, proceeding next to the Assembly floor, whereupon the measure passed with a 67-2-11 vote. Having reached the engrossing and enrolling stage, the bill now awaits action by Governor Newsom. If signed, the bill would take effect at the start of 2023. The bill contains multiple sunset dates, though perhaps the most relevant is the January 1, 2026 sunset, after which time all the provisions added by AB 2449 lapse and become unavailable to local agencies.

The freedoms granted by AB 2449 may be familiar to those accustomed to holding meetings under the framework established by [Assembly Bill 361 \(R. Rivas, 2021\)](#). AB 361 remains in effect through 2023 and can still be used by local agencies during any state-declared emergency. If signed into law, the provisions of AB 2449 would provide an entirely separate and distinct method of conducting remote meetings from that provided by AB 361. Therefore, local agencies would have the option to conduct remote meetings under the provisions of AB 2449, AB 361, or traditional Brown Act teleconference requirements. Local agencies may also choose to conduct public meetings entirely in-person under the Brown Act.

What is different about AB 2449 remote meetings?

Under the provisions of AB 2449, agencies would not be obligated to post agendas at all teleconference locations, would not be obligated to identify all teleconference locations in the meeting agendas, and would not be obligated to make each teleconference location open to the public.

However, for an agency to proceed under the procedures established by AB 2449, it must observe the requirement that *at least* a quorum of the members of the legislative body participates in-person from a singular, physical location clearly identified on the agenda, open to the public, and situated within the boundaries of the territory over which the local agency exercises jurisdiction. This stands in notable contrast to the provisions of AB 361, which contains no such requirement. Under AB 2449, it *would not be permissible* to have the *entirety* of the board participate remotely pursuant to the bill's provisions. Another departure from the AB 361 rules includes the fact that remote participation under AB 2449 must be done for specified reasons — either because of a “just cause” or as a result of “emergency circumstances.” The two cases have different requirements that must be observed and have their own unique restrictions.

The agency must also be prepared to host a robust remote meeting — under the terms of AB 2449, an agency must provide *at least* one of the following so that the public may remotely observe the meeting and provide comments:

A two-way audiovisual platform (defined to mean an online platform that provides participants with the ability to participate in a meeting via both an interactive video conference and a two-way telephonic function); and/or

- A two-way telephonic service *and* a live webcasting of the meeting (defined to mean a telephone service that does not require internet access, is not provided as part of a two-way audiovisual platform, and allows participants to dial a telephone number to listen and verbally participate)

Under what conditions may board members use AB 2449?

Board agency members are also *individually* tasked with observing certain requirements before they can make use of AB 2449’s terms. It is incumbent upon the individual board members themselves to follow certain requirements laid out in the bill; save for some overlapping obligations, the requirements differ based on whether the member’s remote participation is arising out of a “just cause” or “emergency circumstances,” as shown below:

Just Cause”	“Emergency Circumstances”
<p>✓ The member notifies the legislative body at the earliest opportunity possible (including at the start of a regular meeting) of their need to participate remotely for “just cause,” including a general description (typically not exceeding 20 words) of the circumstances relating to their need to appear remotely at the given meeting.</p> <p>Remote participation for “just cause” reasons shall not be utilized by any member of the legislative body for more than two meetings per calendar year.</p> <p>“Just cause” means any of the following:</p> <ul style="list-style-type: none"> • A childcare or caregiving need of a child, parent, grandparent, grandchild, sibling, spouse, or domestic partner that requires them to participate remotely • A contagious illness that prevents a member from attending in person • A need related to a physical or mental disability (as defined [1][2]) not otherwise accommodated • Travel while on official business of the legislative body or another state or local agency 	<p>✓ The member requests the legislative body to allow them to participate in the meeting remotely due to “emergency circumstances” <i>and</i> the legislative body takes action to approve the request. The member shall make this request to participate remotely at a meeting as soon as possible. The legislative body shall request a general description (typically not exceeding 20 words) of the circumstances relating to their need to appear remotely at the given meeting.</p> <p>✓ The member shall make a separate request for each meeting in which they seek to participate remotely.</p> <p>The general description of the circumstances does not require the member to disclose any medical diagnosis or disability, or any personal medical information that is already exempt under existing law, such as the Confidentiality of Medical Information Act.</p> <p>The legislative body may take action on a request to participate remotely at the earliest opportunity. If the request does not allow sufficient time to place proposed action on such a request on the posted agenda for the meeting for which the request is made, the legislative body may take action at the</p>

	<p>beginning of the meeting in accordance with existing law.</p> <p>“Emergency circumstances” means a physical or family medical emergency that prevents a member from attending in person.</p>
<p>✓ The member shall publicly disclose at the meeting, before any action is taken, whether any other individuals 18 years of age or older are present in the room at the remote location with the member, and the general nature of the member’s relationship with any such individual(s).</p> <p>✓ The member shall participate through <i>both</i> audio and visual technology.</p> <p>Under neither case (“just cause”/“emergency circumstances”) do AB 2449’s provisions permit any member of a legislative body to participate in meetings of the legislative body solely by teleconference from a remote location for a period of</p> <ul style="list-style-type: none"> • more than three consecutive months or 20 percent of the regular meetings for the local agency within a calendar year, <i>or</i> • more than two meetings <i>if the legislative body regularly meets fewer than 10 times per calendar year</i> 	

Based on the requirements that both the agency and agency board member must observe, it would be imperative that there is ample coordination taking place in advance of a meeting in order to abide by the terms of AB 2449. While some of the provisions are related to circumstances that are, by nature, difficult or impossible to anticipate, agencies can still prepare in advance for the requirements by ensuring that they operate a remote meeting system that meets all the procedural and substantive requirements of AB 2449, while also developing a means for agency board members to submit their remote meeting requests and preparing the associated recordkeeping related to tracking board member reliance on AB 2449’s provisions. Agencies would also be well-served to ensure board members are familiar with the requirements within AB 2449, particularly the requirement that the board member must participate through both audio and visual technology.

Brown Act Updates: Continued Remote Meetings

Takeaways from New Law AB 2449

AB 2449 – Limited Teleconferencing in Specified Scenarios

AB 2449 reiterates the standard Brown Act teleconference rules, re-codifies the rules set out in AB 361 for times of declared emergency, and also provides for relaxed teleconferencing rules when a member of the legislative body needs to attend remotely for an emergency, or other reasons supported by “just cause.”

Newly Added Teleconference Rules Available Jan. 1, 2023

Under the new teleconference rules, a legislative body may hold a “hybrid” (partial teleconference, partial in-person) meeting without having to comply with certain procedural requirements (post agendas at teleconference locations, identify teleconference locations in the agenda, make all teleconference locations open to the public) in the following limited circumstances:

- One or more members of the legislative body (but less than a quorum) have “just cause” for not attending the meeting in person (childcare or family caregiving need, contagious illness, physical or mental disability need, or travel while on official public business); or
- One or more members of the legislative body (but less than a quorum) experience an emergency circumstance (a physical or family medical emergency that prevents in-person attendance).

Members of legislative bodies who wish to use one of the above exceptions should be sure to contact the agency’s legal counsel before attending a meeting remotely. There are restrictions on the number of times any one member may attend remotely in a year under one of these exceptions. Further, a quorum of the body must still be meeting in-person, and the body must meet the following relaxed remote access rules:

- Provide either a two-way audio visual system or a two-way phone service in addition to live webcasting;
- Identify a call-in or internet-based access option on the agenda, in addition to the in-person meeting location;
- Ensure that if a disruption to the online meeting occurs, the body takes no further action on agenda items until public access is restored; and
- Avoid requiring public comments to be submitted in advance, and provide a real-time option for the public to address the body at the meeting.

AB 361 Rules In Effect Today & Re-Codified in AB 2449

As a reminder, when a state of emergency is involved, a legislative body may hold teleconference meetings without meeting certain procedural requirements (post agendas at teleconference locations, identify teleconference locations in the agenda, make all teleconference locations open to the public) in the following circumstances:

- The meeting is held during a proclaimed state of emergency and state/local officials have imposed or recommended measures to promote social distancing (including, for example Cal-OSHA or other regulatory guidance requiring employees to be trained in social distancing to reduce exposure);
- The meeting is held during a proclaimed state of emergency for the purpose of determining whether meeting in person during the emergency would present imminent risks to the health or safety of attendees; and/or

- The meeting is held during a proclaimed state of emergency and the body has already determined that meeting in person during the emergency would present imminent risks to the health or safety of attendees.

If the body is relying on the above findings to justify meeting by teleconference, it must:

- Give the public notice of how to access the meeting and offer public comment;
- Ensure that if a disruption to the online meeting occurs, the body takes no further action on agenda items until public access is restored;
- Avoid requiring public comments to be submitted in advance, and provide a real-time option for the public to address the body at the meeting; and
- If the state of emergency remains active or social distancing measures continue to be imposed/recommended by state or local officials, continue to make findings supporting the teleconference meetings at least every 30 days.

Original Brown Act Teleconferencing Rules Remain Available

Local agencies may always rely on the teleconferencing rules that applied pre-COVID – all votes must be by rollcall, the meeting must be conducted so as to protect the rights of the public appearing before the body or wishing to comment, all members of the public must be able to access the meeting and provide public comment, teleconference locations must be identified in the agenda, copies of the agenda must be posted at all teleconference locations, and teleconference locations must be open to the public. Finally, at least a quorum of the members of the legislative body who are participating remotely must do so from locations within the agency's jurisdiction.

Meeting Date January 19, 2023		Item # 7 c
		New Business
Subject: Bereavement Leave – Assembly Bill 1949 and Impact on District Policy 2540 Bereavement Leave		
Initiated or requested by	Item Type	Report coordinated or prepared by
<input type="checkbox"/> Board <input type="checkbox"/> Staff <input checked="" type="checkbox"/> Other	<input checked="" type="checkbox"/> Informational <input type="checkbox"/> Direction <input checked="" type="checkbox"/> Action	 <i>Kim Cook</i> Office Manager
Objective		
To review and update the current District Policy 2540 Bereavement Leave to bring policy up to date with Assembly Bill 1949 Bereavement Leave.		
Background		
<p>AB 1949 – Bereavement Leave amends the California Family Rights Act (CFRA) to require that covered employers provide employees with up to five days of bereavement leave for the death of a qualifying family member. This obligation is separate and apart from the 12 weeks of leave employees are eligible to take under the CFRA for their own serious health condition or that of a family member. To be eligible for bereavement leave, an employee must have been employed for at least 30 days, Leave may be taken for the death of an employee’s spouse, domestic partner, parent, parent-in-law, grandparent, grandchild, child, or sibling. The leave must be taken within three months of the family death and can be taken all at once or intermittently. Employers may require that employees take this leave pursuant to any existing bereavement leave policy. If the employer does not have an existing policy, the leave may be unpaid; however, employees may elect to use accrued vacation, personal leave, sick leave, or other compensatory time off.</p>		
Analysis		
Current District Policy 2540 Bereavement Leave states:		
2540.1 This policy shall apply to probationary and regular full-time employees in all classifications.		
2540.2 In the event of a death in the immediate family, an employee may be granted a paid leave of absence not to exceed three days, additional time may be considered depending on distance to be traveled. Verifications may required by the General Manager. This is in addition to regular sick leave and vacation time.		

Budget/Cost Information

TBD

Proposed Action

Update the policy to conform to AB 1949 and update the District Policy 2540. Determine if the update will include pay for only three days and take two days of sick leave or vacation or provide five days of paid leave for full time employees.

Add a section that states part-time employees receive the required five days, but without pay.

Alternative Actions

Discuss and determine different options but update the policy to be in line with AB 1949.

Coordination and Review

This is a standard practice of the Board.

Attachment(s)

District Policy 2540 – Bereavement Leave

Arcade Creek Recreation and Park District

POLICY HANDBOOK

POLICY TITLE: Bereavement Leave
POLICY NUMBER: 2540

2540.1 This policy shall apply to probationary and regular full time employees in all classifications.

2540.2 In the event of a death in the immediate family, an employee may be granted a paid leave of absence not to exceed three days, additional time may be considered depending on distance to be traveled. Verification may be required by the General Manager. This is in addition to regular sick leave and vacation time.

2540.3 "Immediate family" is defined as being spouse, parents, children, grandchild(ren), brother, sister, grandparents, father-in-law, mother-in-law, sister-in-law, brother-in-law or any other person who is a legal dependent of the employee.

Meeting Date January 19, 2023		Item # 7 d
		New Business
Subject: Assembly Bill 1041 – Leave Permitted for a “Designated Person”		
Initiated or requested by <input type="checkbox"/> Board <input type="checkbox"/> Staff <input checked="" type="checkbox"/> Other	Item Type <input checked="" type="checkbox"/> Informational <input type="checkbox"/> Direction <input checked="" type="checkbox"/> Action	Report coordinated or prepared by <i>Kim Cook</i> Office Manager
<p>Objective To add update the Districts current policy 2525 – Family and Medical Leave to include “Designated Person”</p> <p>Background Assembly Bill 1041 – Leave Permitted for a “Designated Person”, states the bill expands the class of people for whom an employee may take caregiver leave under the California Family Rights Act to include a “designated person”. The law defines this term to include any individual related by blood or whose association with the employee is the equivalent of a family relationship. An employee can identify a designated person at the time the employee request CFRA leave.</p> <p>Separately, AB1041 allows an employee to take paid sick leave to care for a “designated person” under the California Health Workplaces, Healthy Families Act of 2014.</p> <p>Analysis Current District Policy 2525 restricts taking time off to care for the following: newborn, adopted, or foster child or for a seriously ill child, parent, or spouse and applies to full-time employees.</p> <p>Employees are required to use applicable accrued paid leaves permitted by the District, including vacation leave and sick leave.</p> <p>Budget/Cost Information TBD</p> <p>Proposed Action Update the policy to conform to AB 1041 and update the District Policy 2525 to include “Designated Person”.</p> <p>Alternative Actions None</p>		

Arcade Creek Recreation and Park District

POLICY HANDBOOK

POLICY TITLE: Family and Medical Leave
POLICY NUMBER: 2525

2525.1 The purpose of this policy is to clarify how Arcade Creek Recreation and Park District will implement the Family and Medical Leave Act of 1993 (FMLA).

2525.2 Eligibility. To be eligible for leave under the FMLA, an employee must have: (1) been employed by Arcade Creek Recreation and Park District for at least 12 months, which need not be consecutive; (2) worked for Arcade Creek Recreation and Park District at least 1,250 hours during the 12 months immediately preceding the commencement of leave

The District is not required by law to implement this policy; however, in the welfare of full time employee's, the District will honor this act.

2525.3 Leave Benefit.

2525.3.1 Eligible employees will be provided with up to 12 weeks of unpaid leave each year to care for a newborn, adopted, or foster child or for a seriously ill child, parent, or spouse. In addition, employees who are unable to perform the functions of their position because of a serious health condition will also be entitled to 12 weeks of unpaid leave. "Serious health condition" is defined as an illness, injury, impairment, or physical or mental condition that entails

- (1) inpatient care in a hospital, hospice, or residential medical care facility; or,
- (2) continuing treatment by a health care provider.

2525.3.2 To be eligible for leave under the FMLA, the employee will first be required to use applicable accrued paid leaves permitted by the District, including vacation leave and sick leave for the first part of the 12-week statutory leave. Paid leave may not be added to the end of the 12 weeks of unpaid leave without the General Manager's prior approval. If a husband and wife are both employed by Arcade Creek Recreation and Park District, the total number of workweeks of leave to which both may be entitled shall be limited to 12 weeks if leave is taken for the birth, adoption, or foster placement of a child or for the purpose of caring for a seriously ill parent.

2525.3.3 Employees on leave who were previously covered by Arcade Creek Recreation and Park District's health benefit shall continue to be covered at the level and under the conditions that coverage would have been provided if the employee were continuing to work.

2525.3.4 At the end of the leave the employee will be reinstated to his/her previous position or to an equivalent job with equivalent pay, benefits, and working conditions. However, the employee will not

accrue seniority or employment benefits (ie: vacation, sick leave, etc) during the leave period. Arcade Creek Recreation and Park District may also require the employee to obtain medical certification that they are able to resume work.

2525.4 Employee Obligations

2525.4.1 If an employee requests leave for the birth, adoption, or the foster placement of a child, and the need for leave is foreseeable, the employee must provide the District with at least 30 days' prior written notice. However, if the date of the birth, adoption, or foster placement requires that leave begin in less than 30 days, the employee must provide the District with as much notice as practicable. If the employee requests leave because of a serious health condition, the employee must provide the District with 30- days notice, or with as much notice as practicable.

2525.4.2 Employees seeking leave on account of a serious health condition must provide the Administrator with medical certification regarding their condition. The Administrator may require employees to obtain, at Arcade Creek Recreation and Park District's expense, a second opinion. If the second opinion differs from the first, the Administrator may require a third opinion from a mutually agreed on health care provider.

2525.4.3 For most leaves, employees will not be permitted to take their leave intermittently or on a reduced-leave schedule without the Administrator's approval. However, intermittent leave or a reduced-leave schedule may, if medically necessary, be taken by the employee because of a serious health condition. An employee who seeks intermittent leave or leave on reduced-leave schedule because of planned medical treatment may be required to transfer temporarily to a different position, with equivalent working conditions, that accommodates recurring periods of leave better than the employee's regular job.

Meeting Date January 19, 2023		Item # 7 e
		New Business
Subject: Nominate a Director for the Special District Advisory Committee (SDAC)		
Initiated or requested by <input type="checkbox"/> Board <input type="checkbox"/> Staff <input checked="" type="checkbox"/> Other	Item Type <input checked="" type="checkbox"/> Informational <input type="checkbox"/> Direction <input checked="" type="checkbox"/> Action	Report coordinated or prepared by <i>Kim Cook</i> Office Manager
Objective To nominate a district board member that expresses interest in serving on the SDAC independent special district, as a commissioner or alternate commissioner.		
Background The SDAC membership of seventeen is composed of the two LAFCo Special District Commissioners, and the Alternate Special District Commissioner, and representatives from recreation and park, fire, water, flood control, cemetery and other types of special districts. SDAC members serve 2-year terms without compensation. There will be seven (7) vacant seats for Office "B" for a full two-year term (1/23 – 12/24) on the Committee. There are also three (3) Office "A" (1/22 – 12/23) vacancies, and directors applying for those slots will serve the remainder of the two-year term that expires in December 2023. New members will be selected by the SDAC <i>Sub-committee on Membership</i> from the pool of nominees provided by the Special Districts, subject to confirmation by the Commission.		
Analysis To participate in the local process representing Recreation and Park District's point of view and to network with Board Members from other agencies can be a benefit.		
Budget/Cost Information None		
Proposed Action Nominate and vote for a Director that expresses interest in serving on this committee.		
Alternative Actions Disregard the interested Director and do not nominate and vote in favor.		
Coordination and Review This is a standard practice of the Board.		Attachment(s) Invitation letter from LAFCo Office A Nomination Form Office B Nomination Form



DATE: December 19, 2022

TO: Independent Special Districts

SUBJECT: Nominations for Membership on SDAC

You are cordially invited to nominate a Member of your Board to join the Special District Advisory Committee (SDAC). The purpose of the Committee is to provide Sacramento LAFCo with input on issues related to Special Districts, as well as to receive information on issues before the Commission.

The SDAC membership of seventeen is composed of the two LAFCo Special District Commissioners, and the Alternate Special District Commissioner, and representatives from recreation and park, fire, water, flood control, cemetery and other types of special districts.

SDAC members serve 2 year terms without compensation. There will be seven (7) vacant seats for **Office "B" for a full two-year terms (1/23 – 12/24)** on the Committee. There are also three (3) **Office "A" (1/22 – 12/23)** vacancies, and directors applying for those slots will serve the remainder of the two year term that expires on December 2023.

New members will be selected by the SDAC *Sub-committee on Membership* from the pool of nominees provided by the Special Districts, subject to confirmation by the Commission.

SDAC meetings are held quarterly on the fifth Tuesday, or as needed. Currently the SDAC meets at 7 PM virtually; however, there will be a discussion on returning to in-person meetings on the January 31, 2023 meeting.

A nomination form is attached. If you wish to nominate a member of your Board, please complete the form and return it to me no later than **Friday, February 15, 2023**.

Please feel free to contact me by email or phone if you have questions about this process.

Sincerely,

José C. Henríquez,
Executive Officer

Commissioners

Sue Frost, Rich Desmond, County Members ■ *Phil Serna, Alternate*
Linda Budge, Sean Loloee, City Members ■ *Vacant, Katie Valenzuela, Alternates*
Chris Little, Public Member ■ *Timothy Murphy, Alternate*
Lindsey Liebig, Gay Jones, Special District Members ■ *Charlea Moore, Alternate*

Staff

José C. Henríquez, Executive Officer ■ *Desirae N. Fox, Policy Analyst* ■ *Diane Thorpe, Clerk of the Commission*
Nancy Miller, DeeAnne Gillick, Commission Counsel



SPECIAL DISTRICT ADVISORY COMMITTEE
Nomination Form
"OFFICE A"

*Recommendation to the **SDAC Selection Committee***

In accordance with the bylaws of the Special District Advisory Committee, the Governing Board of the _____ District nominates _____ (Board Member)

for the following **Office "A"** position on the SDAC:

One year term ends 12/31/23

Signature: _____
Board Chairperson

Date: _____
Please attach resume of nominee

ATTEST:

District Manager or District Secretary

Please print e-mail address

Please send completed nominations to:

José C. Henríquez
Executive Officer.
Sacramento LAFCo
1112 "I" Street; Suite 100
Sacramento CA 95814

henriquezj@saclafco.org



SPECIAL DISTRICT ADVISORY COMMITTEE
Nomination Form
"OFFICE B"

*Recommendation to the **SDAC Selection Committee***

In accordance with the bylaws of the Special District Advisory Committee, the Governing Board of the _____ District nominates _____ (Board Member) for the following **Office "B"** position on the SDAC:

Two year term ends 12/31/24

Signature: _____
Board Chairperson

Date: _____
Please attach resume of nominee

ATTEST:

District Manager or District Secretary

Please print e-mail address

Please send completed nominations to:

José C. Henríquez
Executive Officer.
Sacramento LAFCo
1112 "I" Street; Suite 100
Sacramento CA 95814

henriquezj@saclafco.org

Meeting Date January 19, 2023		Item # 7 f
New Business		
Subject: Discuss relocation of District Office to small rental facility or renovate and update the current office		
Initiated or requested by <input checked="" type="checkbox"/> Board <input type="checkbox"/> Staff <input type="checkbox"/> Other	Item Type <input checked="" type="checkbox"/> Informational <input checked="" type="checkbox"/> Direction <input type="checkbox"/> Action	Report coordinated or prepared by <i>Kim Cook</i> Office Manager
Objective To begin the discussion of either relocating the district office to the small rental facility from its current location or renovate, update, and bring into compliance the current location.		
Background The current location of the District office was originally built as a house in about 1967 (possibly sooner). The building has had little or no upgrades, only basic maintenance. Currently, there are concerns regarding the electrical (no grounding), structural, etc. Unable to determine when the roof may have been replaced. The garage has been pushed off the foundation and the supporting beam in front of the office and garage are detached at the base.		
Budget/Cost Information TBD		
Proposed Action Determine what would be financially the best use of district funds. Renovating and relocating the office to the small rental facility or renovate, update, and bring the current location of the office into compliance (ADA, etc.) and structurally sound.		
Alternative Actions Make no upgrades or changes.		
Coordination and Review This is a standard practice of the Board.		Attachment(s)

Meeting Date January 19, 2023		Item # 7 g
		New Business
Subject: Discuss removal of deck located on the back side of the District Office		
Initiated or requested by <input type="checkbox"/> Board <input checked="" type="checkbox"/> Staff <input type="checkbox"/> Other	Item Type <input type="checkbox"/> Informational <input checked="" type="checkbox"/> Direction <input checked="" type="checkbox"/> Action	Report coordinated or prepared by <i>Kim Cook</i> Office Manager
<p>Objective Discuss removal of the deck located on the back side of the District Office. Or make necessary changes to the current deck.</p> <p>Background. The original deck was installed in March 2000.</p> <p>In May of 2012, the deck was damaged by a large tree that split and a portion fell and damaged the original deck and an area of the office roof. This was submitted as an insurance claim.</p> <p>The current deck was re-designed and replaced in May of 2013 at a cost of about +/- \$9,300.00. This was an approved insurance claim.</p> <p>Currently, the ramp is not ADA compliant and many of the deck boards are a safety concern.</p> <p>Budget/Cost Information The cost will be determined by the discussion to either fix and repair the current deck or remove and redesign a new back deck area.</p> <p>Proposed Action Determine what would be the best solution.</p> <p>Alternative Actions Make no change.</p>		
Coordination and Review This is a standard practice of the Board.		Attachment(s)

Arcade Creek Recreation and Park District

MEETING DATE: January 19, 2023

AGENDA ITEM: 8 Board Discussion

General discussion on topics for future meetings.